



Herais
Lab Solutions

HERAIS MEDICAL LAB EQUIPMENT

Lab & Medical Equipment



HERAIS is committed to making sound decisions to manage our environmental footprint and protect the environment.



A

Anaerobic Jar-----	300
Automobile Exhaust Analyzer-----	380

B

Balance-----	01-12
Bath/Circulator-----	227-236
Blood Bank Instrument-----	276-286
Blood Collection Chair-----	276
Blood Collection Monitor-----	277-278
High Frequency Heat Sealer-----	279
Blood Plasma Extractor-----	279
Low Temperature Blood Operating Bench-----	280
Blood Thaw Machine-----	281-282
Bacterial Colony Counter-----	301
Biological Air Sampler-----	302-304

C

Corpse Refrigerator-----	287
Carbon & Sulfur Analyzer-----	305-306
COD Analyzer-----	307
Colorimeter-----	309-316
Chromatograph-----	355-368
Cooking Oil Tester-----	437-438

D

Dispenser-----	224-226
Dehumidifier-----	323-326
Densimeter-----	327-332

E

Electrophoresis System-----	333-344
Eye Washer-----	345-347

F

Fiber Analyzer-----	348-354
Flash Point Tester-----	393-396

G

Gas Generator-----	369-375
Grain Moisture Meter-----	439-440

H

Hot plate-----	147-151
Heating Mantle-----	152-156
High Pressure Reactor-----	377
High Temperature Thermostatic Circulating Oil/Water Bath-----	378

J

Jacketed Glass Reactor-----	376
Jar Tester-----	379

K

Kjeldahl Apparatus-----	83-92
-------------------------	-------

CONTENTS

M

Microscope-----	13-40
Mixer-----	113-126
Medical Sealer-----	283-286
Morgue Freezer-----	317
Mouse Cage-----	318-322

P

PH Meter-----	157-182
Pipettes-----	215-223
Pump-----	237-252
Vacuum Pump-----	237-238
Peristaltic Pump-----	239-252
Pathology Lab Equipment-----	257-275
Automated Tissue Processor-----	259-260
Manual Rotary Microtome-----	261-262
Semi-Automatic Microtome-----	263
Automatic Microtome-----	264
Cryostat Microtome-----	265
Tissue Embedding Center-----	266-267
Tissue Cooling Center-----	266
Tissue Flotation Water Bath & Slide Dryer-----	268-270
Tissue Flotation Water Bath-----	271
Slide Dryer (Hot Plate)-----	272
Automated Tissue Stainer-----	273
Paraffin Dispenser-----	274
Slides Cabinet-----	275
Pharmacy Instrument-----	287-299
Disintegration Tester-----	287
Dissolution Tester-----	288
Tablet Friability Tester-----	289
Tablet Hardness Tester-----	290
Thaw Tester-----	291
Tablet Four-usage Tester-----	292
Clarify Tester-----	293
Gel Strength Test System-----	294
Laboratory Test Sieve-----	295
Melting Point Apparatus-----	296-299
Polarimeter-----	387-392

R

Rotary Evaporator-----	205-212
Rotary Evaporator-----	205-208 211
Explosion-proof Rotary Evaporator-----	209
Small Capacity Rotary Evaporator-----	210
Water Circulating Vacuum Pump-----	212
Chiller-----	213-214
Refractometer-----	381-386

S

Sample Pre-Processing-----	41-84
Plate Sealer-----	41
Incubator-----	41-52
Ultrasonic Cell Disruptor-----	55-56
Sample Concentrator-----	53-54
Disintegrator-----	57-58
Ball Mill-----	59-65
Grinding Machine-----	63-64
Homogenizer-----	66-70
Disintegrator-----	57-58
Muffle Furnace-----	71-72
Filtration Apparatus-----	73-74
Digester-----	75-84
Shaker-----	99-112
Stirrer-----	127-146
Spectrophotometer-----	183-212
Safety Storage Cabinet-----	253-256
Soil&Plant&Seed Instruments Solution-----	397-440

T

Turbidimeter-----	308
Titrator-----	433-435

U

Ultrasonic Cleaner-----	93-98
-------------------------	-------

V

Viscometer-----	441-444
-----------------	---------

W

Water Activity Meter-----	436
Water Softener-----	445
Water Purifier-----	446-458
Water Distiller-----	459-464

Balance

Semi-micro Analytical Balance

The precision of the semi-microbalance is 0.01 mg. This series is equipped with a new type of highly integrated electromagnetic sensor, all of its models can be automatically internally calibrated, with the characteristics of high precision and high repeatability. All HPBG-type balances are equipped with a large graphic display screen, which is convenient for users to operate.

Function:

- * Recipe database: 99 datas can be stored
- * Automatic internal calibration
- * Tare/counting/percentage test/animal weighing
- * Baud rate is adjustable/ Density function
- * Unit conversion (g/mg/ct/oz...)
- * Multi-Language: English/ German/French/Italian/ Spanish/Portuguese
- * Keep weight values in GLP/ISO format, Includes date, time, and serial number
- * Plastic protection cover for keypad
- * Sensitivity/speed adjustable
- * Overload alarm/fault alarm/level indicator

Optional Accessories:

- * ION-A15 Static Eliminator
- * Balance plate system. USB version (BL0329) or Bluetooth version (BL0330)
- * Alphanumeric external keyboard (AC005)
- * Serial to USB converter (E1002)
- * Serial cable for serial output to printer or computer (E743)
- * Factory calibration certificate (BL0333)



Static Eliminator (Optional)

Technical Parameters:

Model	BA1265SEM	BA2285SEM
Capacity(g)	62/120	82/220
Resolution(g)	0.01mg/0.1mg	
Min Weighing(g)	0.06mg/0.6mg	
Stable Time	≤6s	
Display	LCD (green back light with black font)	
Scale Size	Φ80mm	
Operation Temp	5-25°C	
Repeat Ability	0.03 / 0.1mg	0.05 / 0.1mg
Liner	±0.08 / ±0.2mg	± 0.1/ ± 0.2mg
Draft Shield Size	162*171*225mm	
Cal. Weight	Internal Calibration	
Interface	RS232C	
Power Supply	110-230V 50/60Hz Out DC 12V 1A	
External Size	345*215*345mm	
N. Weight	5.8 kg	
Package Size	510*400*620mm	
G. Weight	8.5kg	



Introduction:

Semi-micro analytical balance adopts high sensitivity and high stability electromagnetic force sensor, stability and accuracy compatible performance to meet the needs of precision weighing laboratory.

Application:

Widely used in scientific research, education, metallurgy, agriculture and other industries.

Features:

- * Transparent glass wind shield, multiple directions can see the sample.
- * LCD display screen.
- * Split-type design, display unit and weighing unit are separated.
- * Digital processing technology, optimized small sample adding weighing function.
- * Built-in RS232 communication interface, can be connected with computers, micro printers.
- * Automatic calibration system.
- * Multiple weighing application functions, basic weighing function, piece weighing function, percentage weighing function.

Technical Parameters:

Model	BA1205SEM	BA1055SEM	BA2085SEM
Capacity	120g	120g/51g	210g/82g
Resolution	0.01mg/0.01mg		
Repeat Ability	±0.05mg	±0.1mg/±0.03mg	±0.1mg/±0.05mg
Liner	±0.05mg	±0.1mg/±0.03mg	±0.1mg/±0.05mg
Operation Temp	10~30°C		
Operating Humidity	10%~70%RH		
Stable Time	6s(average)	2.5s/6s(average)	
Balance Time	30~60min		
Scale Size	Φ90mm		
Power Supply	Standard: AC220V 50/60Hz Optional: AC110V 50/60Hz		
Output Power	DC12V 2A		
External Size(L*W*H)	470*310*320mm		
Package Size(L*W*H)	620*460*560mm		
Net/Gross Weight	12/14kg		

Automatic Electronic Analytical Balance BA-E (External Calibration) & BA-EN (Internal Calibration)

Functions:

- * External calibration (BA1004E&BA2204E)
- * Internal auto calibration (BA1204EN&BA2204EN)
- * Electromagnetic force sensor
- * LCD (White back light with black font)
- * Tare function/Counting/Unit conversion
- * Sensitivity/Speed set/Percentage
- * Density function
- * Accumulation function/peak hold/Upper and lower set
- * Dynamic weighing /Net and Gross/Clock function(optional)
- * Print function (baud rate setting, Continuous communication or press communication)
- * Overload alarm/Fault alarm/Level indicator
- * Optional: Density kit (solid/liquid)/RS485/USB/printer



Technical Parameter:

Model	BA1004E	BA2204E	BA1204EN	BA2204EN
Capacity	100g	220g	120g	220g
Resolution	0.1mg			
Min weighing	0.4mg			
Stable Time	≤3s			
Display	LCD(white back light with black font), 96*24mm			
Scale Size	Φ80mm(Standard), Φ90mm(Optional)			
Operation temp	5~35℃			
Repeat ability	±0.2mg			
Liner	±0.3mg			
Draft shield size	180*175*200mm			
Cal. weight	External Calibration		Internal Calibration	
Interface	RS232C			
Optional	RS485/USB/Printer			
Power Supply	110~240V 50/60Hz			
External Size	300*200*295mm			
Net Weight	5kg			
Package Size	430*320*420mm			
Gross Weight	6.5kg			

Automatic Electronic Analytical Balance BA-C (Internal Calibration)

Features:

- * Humanized design, novel design and five-side full-transparent windshield.
- * A new-generation electromagnetic balance weight sensor guarantees the high precision.
- * Application programs such as automatic fault detection, four-point linear calibration and over-load protection.
- * The adoption of ultra-large digital integrated printed circuit board guarantees high product precision.
- * The adoption of twin-cam mechanism realizes advantageous function of automatic internal calibration which makes product faster and more stable.
- * Application programs such as "Warming", "Calibration", and "Screen Saver".
- * Ultra-large LCD display brings clearer and more comfortable visual sense to operator.



Functions:

- * Multiple functions guarantee easy and reliable operation, including auto-counting, unit conversion (metric carat, gold ounce, etc.), stability, full-scale faring, zero-memory, etc.
- * Built-in automatic calibration guarantees easier, faster, stable and accurate operation of balance.
- * Built-in RS232C output interface guarantees direct connection to external equipment such as computer and printer.
- * Built-in lower weighing hook guarantees convenient use.

Power Supply: AC110-220V/50-60Hz; Power Cord, no battery.

Technical Parameters:

Model	BA604C	BA1004C	BA1204C	BA1604C	BA2004C	BA2204C	BA1003C	BA2003C	BA3003C
Capacity	0~60g	0~100g	0~120g	0~160g	0~200g	0~220g	0~100g	0~200g	0~300g
Readability	0.1mg						1mg		
Scale Size	Φ90mm								
Stable Time	4s	6s			6-8s		1s		
Repeat Ability	0.2mg				0.3mg		1mg		
Liner	0.2mg	0.3mg					1mg		
N.W.	6.8kg								
External Size	350*215*340mm								
Package Size	480*375*515mm								
G.W.	8.5kg								
Work Space Height	240mm								
Calibration	Internal Cal								

Standard Accessory:

Balance body, scale, adaptor, dust guard, cleaning cloth, tweezers and brush.

BA-N Automatic Electronic Analytical Balance (Internal Calibration) (Economic Series)

Features:

- * Humanized design, novel design and four-side transparent windshield.
- * High precision magnet sensor keeps the weighing more fast and stable.
- * Ultra-large backlight LCD display brings clearer and more comfortable visual sense to operate.



Functions:

- * Multiple functions guarantee easy and reliable operation, including auto-counting, unit conversion (g, oz, ct...), full-scale faring, zero-memory etc.
- * Built-in RS232 output interface guarantees direct connection to external equipment such as computer and printer.
- * Built-in automatic calibration guarantees easier, faster, stable and accurate

Power Supply: AC110/220V±10%, 50/60Hz; Power Cord, no battery.

Technical Parameters:

Model	BA1004N	BA1104N	BA1204N	BA2004N	BA2104N	BA2204N
Capacity	0~100g	0~110g	0~120g	0~200g	0~210g	0~220g
Readability	0.1mg					
Scale Size	Φ80mm					
Stable Time	≤3s					
Repeat ability	±0.0003g					
Liner	±0.0003g					
G.W.	10kg					
External Size	365*205*350mm					
Package Size	475*315*485mm					
Work Space Height	230mm					
Calibration	Internal Cal					

Standard Accessory

Balance body, adaptor, weight, windshield.

BA-B Series Electronic Analytical Balance (External Calibration)

Features:

- * Humanized design, novel design and five-side full-transparent windshield.
- * A new-generation electromagnetic balance weighing sensor guarantees high precision.
- * Application programs such as automatic fault detection, four-point linear calibration and over-load protection.
- * Ultra-large LCD display brings clearer and more comfortable visual sense to operate.



Functions:

- * Multiple functions guarantee easy and reliable operation, including auto-counting, unit conversion (metric carat, gold ounce, etc.), stability, full-scale faring, zero-memory, etc.
- * Built-in RS232C output interface guarantees direct connection to external equipment such as computer and printer.
- * Built-in lower weighing hook guarantees convenient use.

Power Supply: AC110-220V/50-60Hz; Power Cord, no battery.

Technical Parameters:

Model	BA504B	BA604B	BA1004B	BA1104B	BA1204B	BA1604B	BA2004B	BA2104B	BA2204B	BA2104S	
Capacity	0~50g	0~60g	0~100g	0~110g	0~120g	0~160g	0~200g	0~210g	0~220g	0~60/60~210g	
Readability	0.1mg									0.1mg/1mg	
Scale Size	Φ80mm										
Stable Time	4s		6s			6-8s			4s		
Repeat Ability	0.2mg						0.3mg			0.2mg/1mg	
Liner	0.2mg		0.3mg			0.2mg/1mg					
N.W.	6.8kg										
External Size	350*215*340mm										
Package Size	480*375*515mm										
G.W.	8.5kg										
Work Space Height	240mm										
Calibration	External Cal										

Standard Accessory:

Balance body, scale, adaptor, Standard weights, dust guard, cleaning cloth, tweezers and brush.

BP-B/P Series Electronic Precision Balance

Features:

- * Humanized design, novel design and five-side full-transparent windshield.
- * A new-generation electromagnetic balance weighing sensor guarantee high precision.
- * Application programs such as automatic fault detection, four-point linear calibration and over-load protection.
- * Ultra-large LCD display brings clearer and more comfortable visual sense to operate.
- * Built-in lower weighing hook guarantees convenient use.



Functions:

- * Multiple functions guarantee easy and reliable operation, including auto-counting, unit conversion (metric carat, gold ounce, etc.), stability, full-scale faring, zero-memory, etc.
- * Built-in RS232C output interface guarantees direct connection to external equipment such as computer and printer.
- * Built-in lower weighing hook guarantees convenient use.

Power Supply: AC110-220V/50-60Hz; Power Cord, no battery.

Technical Parameters:

Model	BP1003B	BP1203B	BP2003B	BP3003B	BP4103B	BP5003B	BP10003	BP1003P	BP2003P
Capacity	0~100g	0~120g	0~200g	0~300g	0~410g	0~500g	0~1000g	0~100g	0~200g
Readability	1mg								
Scale Size	Φ80mm			Φ110mm			Φ80mm		
Stable Time	1s								
Repeat Ability	1mg					2mg			
Liner	1mg			2mg		3mg			
N.W.	6.8kg								
External Size	350*215*340mm								
Package Size	480*375*515mm								
G.W.	8.5kg								
Work Space Height	240mm								
Calibration	External Cal								

Standard Accessory:

Balance body, scale, adaptor, Standard weights, dust guard, cleaning cloth, tweezers and brush.

BP Series Electronic Precision Balance



Functions:

- * Multiple functions including auto-counting, unit conversion (metric carat, gold ounce, etc.), stability, full-scale faring, zero-memory, etc.
- * Built-in RS232C output interface for computer and printer.

Power Supply: AC220V±10%, 50/60Hz; 110V±10%, 50/60Hz, Power Cord, no battery.

Technical Parameters:

Model	Capacity	Readability	Repeatability	Linear Error	Scale Size	Package Size	Gross Weight
BP12002	0~1200g	10mg	10mg	20mg	Φ160mm	480*375*515	8.5kg
BP21002	0~2100g						
BP31002	0~3100g		20mg	30mg			
BP50002	0~5000g						
BP21001	0~2100g	100mg	100mg	100mg			
BP31001	0~3100g						
BP41001	0~4100g						
BP51001	0~5100g						
BP61001	0~6100g				200mg		

Standard Accessory:

Balance body, scale, clean cloth.

BE Series Electronic Balance



Scale Size: Φ 125mm



Scale Size: 130*130mm



Scale Size: 160*160mm



Scale Size: 305*225mm

Features:

- * AC/DC exchangeable, balance level, LCD display, rapid weighing response and high stability.
- * Sensor adopts unique locking device, which guarantees protection of balance during transportation.

Functions:

- * System operations: including auto-counting, percentage, automatic calibration, multi-point calibration, standard weights (optional)
- * Multiple functions guarantee easy and reliable operation, including unit conversion (metric carat, gold ounce, etc.), stability, memory, full-scale faring.
- * Built-in RS232C output interface guarantees direct connection to external equipment such as computer and printer.

Power Supply: AC110/220V \pm 10%, 50/60Hz; Capacity <10kg: Power cord, lithium battery position(9V*1pc)
no battery; Capacity \geq 10kg: Power cord, accumulator.

Technical Parameters:

Model	Capacity	Readability	Repeatability	Linear Error	Scale Size	G.W.	Package Size				
BE1002	0~100g	0.01g	0.01g	0.02g	Φ 125mm	2.3kg	365*265*170mm				
BE2002	0~200g										
BE3002	0~300g										
BE4002	0~400g										
BE5002	0~500g										
BE6002	0~600g		0.02g	130*130mm							
BE10002	0~1000g										
BE20002	0~2000g										
BE30002	0~3000g										
BE50002	0~5000g				0.03g			0.03g	160*160mm		
BE2001	0~200g	0.1g	0.1g	0.1g	Φ 125mm	2.3kg	365*265*170mm				
BE4001	0~400g										
BE5001	0~500g										
BE6001	0~600g										
BE8001	0~800g										
BE10001	0~1000g				130*130mm						
BE16001	0~1600g										
BE20001	0~2000g										
BE30001	0~3000g										
BE40001	0~4000g							160*160mm			
BE50001	0~5000g										
BE60001	0~6000g										
BE80001	0~8000g										
BE100001	0~10000g				0.2g				0.2g	305*225mm	4.5kg
BE150001	0~15000g										
BE200001	0~20000g	0.3g	0.3g								
BE300001	0~30000g										
BE1000	0~1000g	1g	1g	1g	130*130mm	2.3kg	365*265*170mm				
BE2000	0~2000g										
BE3000	0~3000g										
BE6000	0~6000g				160*160mm						
BE10000	0~10000g										
BE15000	0~15000g										
BE20000	0~20000g				305*225mm			4.5kgm	460*395*250mm		
BE30000	0~30000g										

BE-G/N Classic Electronic Balance (Economic Series)



Scale Size: Φ130mm
BE1002G / BE2002G / BE3002G /
BE6002G / BE10002G



Scale Size: Φ160mm
BE20002G / BE30002G /
BE40002G / BE50002G



Scale Size: Φ200*200mm
BE60001GF/BE100001GF/
BE150001GF / BE6000GF /
BE10000GF / BE15000GF



Scale Size: Φ130mm
BE1002N / BE2002N / BE3002N /
BE5002N / BE6002N / BE10002N /
BE3001N / BE6001N / BE10001N



Scale Size: Φ160mm
BE20001NF / BE30001NF /
BE50001NF

Features:

- * AC/DC exchangeable, LCD display, rapid weighing response and high stability.
- * Precision scales calibrated sensor window can effectively make the calibration more accurate(only for BE-G/GF series).
- * External Material:
BE-G/GF series, stainless steel scale, plastic case and aluminum base thick of 3.8mm,
BE-N/NF series, stainless steel scale, plastic case and ABS base
- * Superior wireless sensors realize no-button operation of peeled, calibration, avoiding button corrosion by the sample residues.

Optional Functions:

- Anti-theft device&Sealing device (Only for BE-G/GF series)
- Weighing function under the hanging structure, or test weight for weighing magnetic object density, specific gravity, etc.

Power Supply

- AC220V±10%, 50/60HZ; 110V±10%, 50/60HZ
- Power cord, dry battery reservation position (AA*6pcs), no battery, no accumulator.

Standard Weight:

Model	Readability			
	1mg	10mg	100mg	1g
200g> Capacity≥100g	100g weight	100g weight	No weight	No weight
500g> Capacity≥200g	200g weight	200g weight	No weight	No weight
Capacity≥500g	500g weight	500g weight	No weight	No weight

Technical Parameters:

Model	Capacity	Readability	Repeatability	Linear Error	Scale Size	G.W.	Package Size	Interface	
BE1002G	100g	10mg	±10mg	±10mg	Φ130mm	3.8kg	350*290*160 mm	RS232 (Standard) RS485 (Optional)	
BE2002G	200g								
BE3002G	300g								
BE6002G	600g				Φ160mm	4.2kg			
BE10002G	1000g								
BE20002G	2000g								
BE30002G	3000g	100mg	±100mg	±100mg	200*200mm	4.5kg			
BE40002G	4000g								
BE50002G	5000g								
BE60001GF	6000g				1g	±1g			±1g
BE100001GF	10000g								
BE150001GF	15000g								
BE6000GF	6000g	10mg	±10mg	±10mg	Φ130mm	2.4kg			
BE1000GF	1000g								
BE1500GF	1500g								
BE1002N	100g				100mg	±100mg	±100mg	Φ160mm	1.9kg
BE2002N	200g								
BE3002N	300g								
BE5002N	500g	2kg							
BE6002N	600g								
BE10002N	1000g								
BE3001N	300g	100mg	±100mg	±100mg	2kg				
BE6001N	600g								
BE10001N	1000g								
BE20001NF	2000g								
BE30001NF	3000g								
BE50001NF	5000g								

Large-scale Electronic Balance



Introduction:

Large-scale electronic balance has fluent and novel appearance as well as new design, which bring faster weighing response. Unique metal base and mechanical structure guarantee higher stability and stronger anti-interference performance. AC/DC exchangeable for portability and field operation.

Besides, we can also customize special specifications upon customer's request.

Feature:

- * The unique appearance design makes the product have high stability, and the backlit LCD screen makes the operator's vision more comfortable.
- * With AC and DC power supply, valve regulated lead-acid battery.
- * With a variety of measurement unit conversion, count, percentage, multi-point calibration.
- * The built-in RS232C output interface can be used with computers, printers and other equipment.

Technical Parameters:

Model	Capacity	Readability	Power Supply	Scale Size (mm)	External Size (W*D*H) mm	Net Weight	Package Size (W*D*H) mm	Gross Weight
BE40000L	0-40000g	1g	100~240V, 50/60Hz	500*400	530*300*680	11kg	870*465*225	14kg
BE50000L	0-50000g							
BE60000L	0-60000g							
BE100000L	0-100000g							
BE150000L	0-150000g							
BE200000L	0-200000g							
BE300000L	0-300000g	10g						
BE50000L-10	0-50000g							
BE60000L-10	0-60000g							
BE100000L-10	0-100000g							
BE150000L-10	0-150000g							
BE200000L-10	0-200000g							
BE300000L-10	0-300000g	50g						
BE500000L-10	0-500000g							
BE100000L-50	0-100000g							
BE150000L-50	0-150000g							
BE200000L-50	0-200000g							

BM-50 Series Rapid Moisture Meter

Features:

- * LCD Display
- * RS232 communication interface
- * Convenient and quick operating with 6 buttons.
- * Heating element, Halogen lamps, proper for samples requires quick heating.
- * Adopting heating-insulated weighing sensor avoids accuracy affected by heating.



Technical Parameters:

Model	BM-50-10	BM-50-5	BM-50-1
Capacity	50g		
Weight Readability	0.01g	0.005g	0.001g
Repeatability Standard Deviation	0.01g	0.05g	0.002g
Linear Error	0.01g	0.05g	0.002g
Moisture Percentage Accuracy	0.3%	0.2%	0.1%
Scale Size	Φ90mm		
Temperature Capacity	50~180°C	50~180°C	50~180°C
Ambient Temperature	10~30°C	10~30°C	10~30°C
Power Supply	AC110/220V±10%, 50/60Hz; Power cord, no battery		
Package Size	370*470*350mm		
Gross Weight	4.1kg		

Electronic Density (Specific Gravity) Balance



Technical Parameters:

Model	BA-100D	BA-200D
Max Capacity	100g	200g
Repeatability	10mg	
Linear Error	20mg	
Min Capacity	10mg	
Fixed Support	H=203mm	
Scale Size	Φ110mm	
Output	RS-232C	
Power Supply	AC110/220V±10%, 50/60Hz; Power cord, no battery	
Gross Weight	3.2kg	
Package Size	377*281*278mm	
Accessories	Measuring platform, measuring cup, fixed support, thermometer, doublehook weights, platinum wire, plumb bob, wire basket, balance body, adaptor and standard weights	

Microscope

Microcirculation Microscope

Application:

Microcirculation microscope is used for the early diagnosis, guide treatment and observation for various diseases including cardiovascular, diabetes, hypertension, stroke, rheumatoid arthritis, etc. It is widely used in medicine, health care products, human health consulting, beauty care and other fields. It is also used for individual microcirculation monitoring.



WXH-8



WXH-10/12

Technical Parameters:

Model	WXH-8	WXH-10	WXH-12
Magnification	380X	480X	580X
Display Size(mm)	161*121	204*153	185*240
Objective	10X		
Focus System	Coaxial coarse/ slightly adjusted, Z-axis movement, mechanical upper and lower limits		
Stage	360°revolve, X, Y axis movement, moving range 30*80mm		
Illumination	LED illumination with high brightness and lower consumption, new luminaire with lower temperature and 10,000-200,000h working life, 90°revolve left and right		
Power Supply	AC100-230V, 50/60Hz		
Camera	Color camera system, HD LCD display		
Standard Accessory	Aluminum box, display screen, power cable, asphalt, manual, Flip chart, microcirculation flattery		
Package Size	270*340*380mm	300*380*380mm	
Gross Weight	5.5kg	7kg	

Biological Microscope



BM-A106



BM-A118



BM-A206



BM-T300



BM-T310

Technical Parameters:

Model		BM-A106	BM-A118	BM-A206
Objective	4X, 10X, 40X (spring)	√	√	√
Eyeiece	Wide field eyepieces WF10X, (WF25XorWF20X,WF16X or H16X optional)	√	√	√
Viewing Head	Monocular	√	√	√
Nosepiece	Triple	√	√	√
Stage	Plain stage with paired clips	√	√	√
	Plain stage with moving scale	●	/	●
Focusing	Coarse adjustment focusing	√	√	√
	Coaxial coarse and fine adjustment focusing	/	/	/
Illumination & Condenser	Rotating disc diaphragm	√	/	√
	N.A=0.65 abbe condenser & rotating disc diaphragm	/	√	/
	Flat concave reflector	/	/	/
	Electric light source top LED (incandescent optional)	/	/	/
Power	Electric light source bottom LED (incandescent optional)	/	/	/
	Electric light source top and bottom LED (incandescent optional)	√	√	√
Power	Power: battery	√	√	√
	AC Input 100-230V, DC Output 5V	/	√	√
Package Size(mm)		160	160	160
		*220	*220	*220
Gross Weight(kg)		*300	*300	*300
		1.8	2.5	2

Model		BM-T300	BM-T310
Objectives	Achromatic objectives: 4X, 10X, 40X(S), 100X(S, Oil)	√	√
	Plan objectives: 4X, 10X, 40X(S), 100X(S, Oil)	●	●
	Infinite achromatic objectives: 4X, 10X, 40X(S), 100X(S, Oil)	●	●
	Infinite plan objectives: 4X, 10X, 40X(S), 100X(S, Oil)	●	●
Eyeiece	Wide field eyepiece: WF10X(18mm), (WF16X optional)	√	√
Viewing Head	Compensation free binocular head, inclined at 30°	√	/
	Compensation free trinocular head, inclined at 30°	/	√
Nosepiece	Quadruple	√	√
Stage	Double layer mechanical stage size 140X205mm, moving range 77X50 mm	√	√
Focusing	Coaxial coarse and fine adjustment, focusing range 30mm, focusing interval 0.002mm	√	√
Condenser	Abbe NA=1.25 with iris diaphragm & filter	√	√
Illumination	High LED light source	√	√
Power	AC input 100-230V, DC output 12V	√	√
Package Size(mm)		485	485
		*335	*335
Gross Weight(kg)		*255	*255
		7.5	8

Note: √ Standard Outfit, ● Optional

Biological Microscope



BM-B100 BM-B101 BM-B102 BM-B103 BM-B104 BM-B105 BM-B106 BM-B108

Technical Parameters:

Model		BM-B100	BM-B101	BM-B102	BM-B103	BM-B104	BM-B105	BM-B106	BM-B108
Eyeiece	Wide Field Eyepieces WF10X (WF16X or H16X optional)	√	√	√	√	√	√	√	√
Viewing	Monocular	√	√	√	√	√	√	√	√
Head	Monocular with video teaching head	√	√	√	√	√	√	√	√
	Compensation free binocular head	√	√	√	√	√	√	√	√
	Compensation free trinocular head	√	√	√	√	√	√	√	√
Objective	4X, 10X, 40X (spring)	√	•	•	•	•	•	•	•
	10X, 40X (spring), 100X(spring, oil)	•	•	√	•	•	•	•	•
	4X, 10X, 40X (spring), 100X(spring, oil)	•	√	•	√	√	√	√	√
		•	√	•	√	√	√	√	√
Nosepiece	Triple Nosepiece	√	•	√	•	•	•	•	•
	Quadruple Nosepiece	•	√	•	√	√	√	√	√
Stage	Double layer mechanical stage, size:110x115mm	√	√	√	√	√	√	√	√
	Plain Stage with paired clips	√	√	•	√	•	√	•	√
	Plain Stage with moving scale	•	√	√	√	√	√	√	√
Focusing	Coaxial Coarse and Fine Adjustment, Focusing Range 20mm	√	√	√	√	√	√	√	√
Condenser	N.A.=1.25 Abbe condenser & Iris diaphragm (optional)	•	√	•	√	√	√	√	√
	N.A.=0.65 Abbe condenser & Iris diaphragm	√	√	√	√	•	√	•	√
Illumination	Electric light source LED	√	√	√	√	√	√	√	√
Diaphragm	Rotating disc diaphragm	•	√	√	√	√	√	√	√
Power Supply	AC Input 100~230V, DC Output 12V	√	√	√	√	√	√	√	√
Package Size (mm)		210	210	210	210	270	270	270	270
		*280	*280	*280	*280	*310	*310	*310	*310
		*400	*400	*400	*400	*410	*410	*410	*410
Gross Weight		3kg	3.5kg	3.5kg	4kg	4kg	4.5kg	4.5kg	4.8kg

Note: √ Standard Outfit, • Optional, \ Without this feature

Biological Microscope



BM-F101 BM-F102 BM-F103 BM-F104 BM-F105 BM-F106 BM-F108

Technical Parameters:

Model		BM-F101	BM-F102	BM-F103	BM-F104	BM-F105	BM-F106	BM-F108
Eyeiece	Wide Field Eyepieces WF10X(WF25X or WF20X or WF16X Optional)	√	√	√	√	√	√	√
Viewing Head	Compensation Free Binocular Head					√		
	Dual Viewing Head, one Tube 30° Inclined and Another Tube Vertical, 360° Rotatable		√	√				
	Compensation Free Trinocular Head						√	√
	Monocular	√						
Achromatic Objective	4X,10X,40X(Spring),100X (Spring, Oil)(185)	√	√	√	√	√	√	√
	4X,10X,40X (Spring), 100X (Spring, Oil)(195)	•	•	•	√	•	•	•
Nosepiece	Triple Nosepiece	•	•	•	•	•	•	•
	Quadruple Nosepiece	√	√	√	•	√	√	√
Stage	Double Layer Mechanical Stage, Size:110√135mm	√		√		√		√
	Plain Stage with Moving Scale	√	√		√		√	
Focusing	Coaxial Coarse and Fine Adjustment, Focusing Range 20mm	√	√	√	√	√	√	√
Condenser	Simple N. A=1.25 Abbe Condenser & Iris Diaphragm		√		√		√	
	Handwheel Adjustment N.A=1.25 Abbe Condenser & Iris Diaphragm	√		√	√	√		√
Illumination	No Strobe High Brightness LED Light	√	√	√	√	√	√	√
Power Supply	AC Input 100~230V, DC Output 12V	√	√	√	√	√	√	√
Package Size(W*D*H) mm		270*310*410						
Gross Weight(kg)		4	4	4.2	4.5	5	5	5.2

Note: √ Standard Outfit, • Optional

Biological Microscope



BM-Z102

BM-Z104

BM-Z106

BM-Z110

BM-Z112

Technical Parameters:

Model		BM-Z102	BM-Z104	BM-Z106	BM-Z110	BM-Z112
Eyepiece	Wide field eyepiece: WF10X, (WF16X optional)	√	√	√	√	√
Viewing Head	Compensation free binocular head inclined at 30°	/	√	/	/	/
	Sliding binocular head inclined at 45°	/	/	√	/	/
	Sliding trinocular head, Inclined at 45°	/	/	/	/	√
	Monocular with video teaching head	√	/	/	/	/
Achromatic Objective	4X, 10X, 40X(Spring), 100X(Spring, oil)	√	√	√	√	√
Nosepiece	Quadruple nosepiece	√	√	√	√	√
Stage	Double layer mechanical stage size 132*140mm, moving range 75*45mm	√	√	√	√	√
Base Accessories	Black decorative panel	●	●	●	●	√
Focusing	Coaxial coarse and fine adjustment, focusing range 30mm, focusing interval 0.002mm	√	√	√	√	√
Condenser	Abbe NA=1.25 with iris diaphragm & filter	√	√	√	√	√
Illumination	LED light source (Halogen lamp optional)	√	√	√	√	√
Power Supply	AC Input 100-230V, DC Output 12V	√	√	√	√	√
Package Size(W*D*H) mm	320*280*420mm					
Gross Weight(kg)	5.2		5.6	5.6	6	6

Note: √ Standard Outfit, ● Optional

Economical Biological Microscope



BME-500D

BME-500E

BME-500SM

BME-500V

Technical Parameters:

Model	BME-500D	BME-500E	BME-500SM	BME-500V
Viewing Head	Monocular head inclined at 45°, 360° rotatable	Compensation free binocular head inclined at 30°, 360° rotatable	Compensation free trinocular head, 360° rotatable	Dual viewing head, one tube 30°, inclined and another tube vertical, 360° rotatable
Achromatic Objectives	4X, 10X, 40X(Spring), 100X(Spring, Oil)			
Eyepiece	Wide field eyepiece: WF10X, (WF16X optional)			
Stage	Double layer mechanical stage size 120X125mm			
Focusing	Coaxial coarse and fine adjustment, focusing range 30mm, focusing interval 0.002mm			
Condenser	Abbe NA=1.25 with iris diaphragm&filter			
Illumination	LED(1W) lamp 220V or 110V, (LED 3W lamp optional)			
Power Supply	AC110/220V±10%, 50/60Hz			
Package Size	450*360*240mm			
Gross Weight	5kg			

Note: Trinocular microscope can be installed camera. 110V/220V for LED lamp.

Biological Microscope



BM-2CA



BM-2CBA



BM-8C



BM-8CA

Technical Parameters:

Model	BM-2CA	BM-2CBA
View Head	Compensation free binocular head, Inclined at 30°, 360° rotatable, Interpupillary 55~75mm	Compensation free trinocular head, Inclined at 30°, 360° rotatable, Interpupillary 55~75mm
Eyepiece	P10X/18mm, P16X/11mm	
Objective	4X N.A=0.10 WD=37.50mm	
	10X N.A=0.25 WD=7.31mm	
	40X N.A=0.65 WD=0.63mm	
	100X(Oil) N.A=1.25 WD=0.18mm	
Focusing	Coaxial Coarse & Fine Adjustable System, Range 15mm, Fine Division 0.002mm	
Stage	Mechanical Stage 130*130mm, Moving Range 70*30mm, Vernier 0.1mm	Mechanical Stage 130*125mm, Moving Range 70*30mm, Vernier 0.1mm
Condenser	Abbe NA1.25 centerable condenser with Iris Diaphragm & Filter	
Illumination	LED lamp, brightness adjustable	
Filter	Blue, yellow, green	
Power Supply	AC85~265V, 50/60Hz	
Package Size	435*330*235mm	335*215*470mm
Gross Weight	5.5kg	

Technical Parameters:

Model	BM-8C	BM-8CA
View Head	Compensation free binocular head, Inclined at 30°, 360° rotatable, Interpupillary 55~75mm	Compensation free trinocular head, Inclined at 30°, 360° rotatable, Interpupillary 55~75mm
Eyepiece	P10X/18mm, P16X/11mm	
Objective	4X N.A=0.10 WD=37.50mm	
	10X N.A=0.25 WD=7.31mm	
	40X N.A=0.65 WD=0.63mm	
	100X(Oil) N.A=1.25 WD=0.18mm	
Focusing	Coaxial Coarse & Fine Adjustable System, Range 30mm, Fine Division 0.002mm	
Stage	Double Layers Mechanical Stage 155*145mm, Moving Range 80*50mm	Mechanical Stage 140*140mm, Moving Range 75*50mm, Vernier 0.1mm
Condenser	Abbe NA1.25 centerable condenser with Iris Diaphragm & Filter	
Illumination	Halogen lamp 6V/20W, Kohler illumination, brightness adjustable	
Filter	Blue, yellow, green	
Power Supply	AC85~265V, 50/60Hz	
Package Size	355*265*495mm	
Gross Weight	6kg	7.5kg

Biological Microscope



BBM-17

BBM-17A

BBM-17AP

Technical Parameters:

Model	BBM-17	BBM-17A	BBM-17AP
View Head	Compensation free binocular head, Inclined at 30°, 360° rotatable, Interpupillary 45~75mm	Compensation free trinocular head, Inclined at 30°, 360° rotatable, Interpupillary 45~75mm	Compensation free trinocular head, Inclined at 30°, 360° rotatable, Interpupillary 48~75mm
Eyepiece	WF 10X/22mm, P16X/15mm (Optional)		WF 10X/22mm, P16X/15mm (Optional)
Infinite Achromatic Objective	4X N.A=0.10 WD=20.00mm		
	10X N.A=0.25 WD=13.50mm		
	40X N.A=0.65 WD=0.68mm		
	100X(Oil) N.A=1.25 WD=0.20mm		
Focusing	Coaxial Coarse & Fine Adjustable System, Range 30mm, Fine Division 0.002mm		
Stage	Mechanical Stage 140*160mm, Moving Range 76*45mm		
Condenser	Abbe NA1.25 centerable condenser with Iris Diaphragm & Filter		
Illumination	LED lamp, brightness adjustable		
Filter	Blue, green		
Power Supply	AC85~265V, 50/60Hz		
Package Size	405*260*510mm		
Gross Weight	8.3kg		8.5kg

Trinocular UIS Biological Microscope



Technical Parameters:

Model	BM-20A
Optical System	Infinite optical system
View Head	Compensation Free Trinocular Head, Inclined at 30°, 360° rotatable, interpupillary 55~75mm
Eyepiece	P10X/22mm, P16X/15mm
Infinite Plan Achromatic Objective	4X N.A=0.10 WD=20.00mm
	10X N.A=0.25 WD=13.50mm
	40X N.A=0.65 WD=0.68mm
	100X(Oil) N.A=1.25 WD=0.20mm
Focusing	Coaxial Coarse & Fine Adjustable System, Range 30mm, Fine Division 0.002mm
Stage	Double Layers Mechanical Stage 155*145mm, Moving Range 80*50mm
Condenser	Abbe NA1.25 centerable condenser with Iris Diaphragm & Filter
Illumination	Halogen lamp 6V/20W, Kohler illumination, brightness adjustable
Filter	Blue, yellow, green
Power Supply	AC85~265V, /60Hz
Package Size	335*260*560mm
Gross Weight	10kg

XS-208 Series Laboratory Biological Microscope



Technical Parameters:

	Specification	Model					
		XS-208A	XS-208B	XS-208C	XS-208AP	XS-208BP	XS-208AB
Viewing Head	Sliding Binocular Head Inclined at 45°	√					
	Sliding Trinocular Head Inclined at 45°		√				
	Compensation Free Binocular Head inclined at 30°				√		√
	Compensation Free Trinocular Head inclined at 30°			√		√	
Nosepiece	Ball Beating Quadruple Nosepiece	√	√	√	√	√	√
Eyepiece	Wide Field Plane-scope Eyepiece: WF10X/18mm	√	√	√	√	√	√
	Achromatic 4X, 10X, 40X(Spring)100X(Spring, Oil)	√	√		√	√	√
Objective	Infinite Plan Achromatic 4X, 10X, 40X(Spring)100X(Spring, Oil)			√	√		
	Double Layer Mechanical Stage 135*140mm	√	√	√	√	√	√
Stage	ABBE NA1.25 condenser with Iris Diaphragm&filter, rack&pinion adjustment	√	√	√	√	√	√
Condenser	Build-in Illumination, LED lamp	√	√	√	√	√	√
Illumination	AC110/220V±10%, 50/60Hz	√	√	√	√	√	√
Power Supply	Dark field condenser, Phase contrast kit	√	√	√	√	√	√
Optional Accessories	Carton with foam	√	√	√	√	√	√
Package	250*360*460mm	√	√	√	√	√	√
Package Size	8kg	√	√	√	√	√	√
Gross Weight							

Optional: 2.0, 3.0 or 5.0 Megapixel, CMOS electronic eyepiece(only for Trinocular microscope).

XSB-Series Laboratory Biological Microscope



Technical Parameters:

	Specification	Model			
		XSB-301P	XSB-301B	XSB-102B	XSB-301A
Viewing Head	Compensation Free Binocular Head inclined at 30°				
	Compensation Free Trinocular Head inclined at 30°	√	√		
	Sliding Binocular Head inclined at 45°			√	
	Sliding Trinocular Head inclined at 45°				√
Nosepiece	Ball Beating Quadruple Nosepiece	√	√	√	√
Eyepiece	Wide Field Plane-scope Eyepiece: WF10X/18mm	√	√	√	√
	Plan Achromatic 4X, 10X, 40X(Spring)100X(Spring, Oil)	√			
Objective	Achromatic 4X, 10X, 40X(Spring)100X(Spring, Oil)		√		√
	Achromatic 10X, 20X, 40X(Spring)100X(Spring, Oil)			√	
Stage	Double Layer Mechanical Stage 135*140mm	√	√	√	√
	Abbe NA1.25 condenser with Iris Diaphragm & filter, rack&pinion adjustment	√	√	√	√
Condenser	Build-in Illumination, Halogen lamp 6V/20W, Power Suooly 220V	√	√	√	√
Illumination	AC110/220V±10%, 50/60Hz	√	√	√	√
Power Supply	Dark field condenser, Phase contrast kit, Constant temperature platform	√	√	√	√
Optional Accessories	Each set in styrofoam, to carton for safety	√	√	√	√
Package	Carton with foam	√	√	√	√
Package	240*340*400mm	√	√	√	√
Package Size	7kg	√	√	√	√
Gross Weight					

Note: 110V/220V for LED lamp, 220V only for Halogen lamp

Optional: 2.0, 3.0 or 5.0 Megapixel, CMOS electronic eyepiece(only for Trinocular microscope)

BX-Series Laboratory Biological Microscope



BX-101A



BX-101B



BX-102A



BX-102B



BX-102C



BX-103C

Technical Parameters:

	Specification	Model		
		BX-101A	BX-101B	BX-102A
Viewing Head	Monocular Head inclined at 45°	√		
	Dual Observation 45°, -90° inclined and vertical 360° rotatable		√	
	Sliding Binocular Head inclined at 45°			√
	Compensation Free Binocular Head inclined at 30°			
	Sliding Free Trinocular Head inclined at 45°			
Nosepiece	Ball Beating Quadruple Nosepiece	√	√	√
Eyepiece	Wide Field Plane-scope Eyepiece: WF10X 18mm	√	√	√
Objective	Achromatic 4X, 10X, 40X(Spring)100X(Spring, Oil)	√	√	√
Stage	Double Layer Mechanical Stage 115*125mm moving range 30*50mm	√	√	√
Condenser	Abbe NA1.25 condenser with Iris Diaphragm & filter, rack&pinion adjustable	√	√	√
Illumination	Build-in Illumination, Halogen lamp 6V/20W, Power Suooly 220V, 3W LED	√	√	√
Power Supply	AC110/220V±10%, 50/60Hz	√	√	√
Package	Cartoon with foam	√	√	√
Package Size	230*360*460mm	√	√	√
Gross Weight	6kg	√	√	√

Note: 110V/220V for LED lamp, 220V only for Halogen lamp

Optional: 2.0, 3.0 or 5.0 Megapixel, CMOS electronic eyepiece(only for Trinocular microscope)

Technical Parameters:

	Specification	Model		
		BX-102B	BX-102C	BX-103C
Viewing Head	Monocular Head inclined at 45°			
	Dual Observation 45°, -90° inclined and vertical 360° rotatable			
	Sliding Binocular Head inclined at 45°	√		
	Compensation Free Binocular Head inclined at 30°		√	
	Sliding Free Trinocular Head inclined at 45°			√
Nosepiece	Ball Beating Quadruple Nosepiece	√	√	√
Eyepiece	Wide Field Plane-scope Eyepiece: WF10X 18mm	√	√	√
Objective	Achromatic 4X, 10X, 40X(Spring)100X(Spring, Oil)	√	√	√
Stage	Double Layer Mechanical Stage 115*125mm moving range 30*50mm	√	√	√
Condenser	Abbe NA1.25 condenser with Iris Diaphragm & filter, rack&pinion adjustable	√	√	√
Illumination	Build-in Illumination, Halogen lamp 6V/20W, Power Suooly 220V, 3W LED	√	√	√
Power Supply	AC110/220V±10%, 50/60Hz	√	√	√
Package	Cartoon with foam	√	√	√
Package Size	230*360*460mm	√	√	√
Gross Weight	6kg	√	√	√

Note: 110V/220V for LED lamp, 220V only for Halogen lamp

Optional: 2.0, 3.0 or 5.0 Megapixel, CMOS electronic eyepiece(only for Trinocular microscope)

Multi-function Biological Microscope



BMM-1000



BMM-2000

Technical Parameters:

Model		BMM-1000	BMM-2000
Optical System	Infinite optical system	/	√
Viewing Head	Siedentopf binocular viewing head, inclined at 30°, 360° rotatable, Interpupillary 48-75mm	√	√
	Siedentopf trinocular viewing head, inclined at 30°, 360° rotatable, Interpupillary 48-75mm	•	•
Eyepiece	WF10×/18	√	\
	P16×/11	•	\
	WF10×/20	\	√
	WF15×/16	\	•
Objective	Achromatic objective 4×, 10×, 40×, 100×	√	\
	Plan achromatic objective 4×, 10×, 40×, 100×	•	\
	Infinite plan achromatic objective 20×, 60×	\	•
	Infinite plan achromatic objective 4×, 10×, 40×, 100×	•	√
Nosepiece	Quadruple nosepiece	√	\
	Backward quadruple nosepiece	\	√
	Backward quintuple nosepiece	\	•
Focusing	Coaxial coarse & fine adjustment, fine division 0.002mm, coarse stroke 37.7mm per rotation, fine stroke 0.2mm per rotation, moving range 20mm	√	√
Stage	Double layers mechanical stage: 132*142mm, moving range: 75*40mm	√	\
	Rectangular 230*150mm stage, moving range: 78*54mm, using low-positioned X/Y coaxial control knob	\	√
Condenser	Abbe condenser NA1.25 with aperture diaphragm	√	√
Illumination	S-LED Illumination, brightness adjustable	√	√
	12V/20W Halogen lamp, brightness adjustable	•	•
Power Supply	Kohler illumination	•	•
	110~220V, 50/60Hz	√	√
Accessories	Photo attachment, video attachment	•	•
	Dark field condenser	•	\
	Polarization set, phase contrast kit	\	•
Package Size	323*264*440mm(BMM-1000), 380*260*510mm(BMM-2000)	√	√
Gross Weight	6.5kg(BMM-1000), 10kg(BMM-2000)	√	√

Note: √ Standard Outfit, • Optional, \ Without this feature

Digital Biological Microscope



DM-125

DM-300M

Features:

- * The integration of structure design, to save space.
- * Valid moldproof design, it can be used under the high temperature and high humidity environment.

Technical Parameters:

Model		DM-125	DM-300M
Optical System	Infinite Optical System	/	√
	Finite Optical System	√	/
Viewing Head	Siedentopf Binocular Viewing Head Inclined at 30°, Interpupillary 47-78mm	√	/
	Siedentopf Trinocular Viewing Head Inclined at 30°, Interpupillary 47-78mm	•	/
	Siedentopf Binocular Viewing Head, 30° Inclined, Interpupillary 48-75mm	/	√
	Siedentopf Trinocular Viewing Head, 30° Inclined, Interpupillary 48-75mm	/	•
	MD101 Microscope Camera with HD Monitor, 5M pixels, Colour CMOS	•	•
Eyepiece	Wide Field Eyepiece WF 10×/18	√	√
	Extra Wide Field Eyepiece EW10×/20 with Diopter Adjustment	/	•
Objective	Achromatic Objective 4×, 10×, 40×, 100×	√	/
	Infinite Semi-plan Achromatic Objectives 4×, 10×, 40×, 100×	/	√
	Infinite Plan Achromatic Objectives 4×, 10×, 40×, 100×	/	•
Nosepiece	Backward Quadruple Nosepiece	√	/
	Quadruple Nosepiece	/	√
Stage	Double Layers Mechanical Stage 140mm×140mm/ 75mm×50mm	√	√
Condenser	NA1.25 Abbe Condenser	√	/
	Sliding-in Centerable condenser NA1.25	/	√
	Dark Field Condenser (Dry, Oil)	•	/
Focusing System	Coaxial Coarse and Fine Adjustment, Fine Division 0.002mm, Coarse Stroke 37.7mm per Rotation, Fine Stroke 0.2mm per Rotation, Moving Range 20mm	/	√
	Coaxial Coarse and Fine Adjustment, Fine Division 0.002mm, Moving Range 25mm	√	/
Illumination	6V/ 20W Halogen Lamp, Brightness Adjustable	•	•
	S-LED Illumination, Brightness Adjustable	√	√
Accessories	Phase Contrast Kit, Fluorescent Attachment, Polarization Set	•	•
Power Supply	AC 110-220V, 50/60HZ	√	√
Packing Size(mm)	380*270*470mm (DM-125 Main body) 350*350*640(DM-300M)	√	√
Gross Weight(kg)	8.5(DM-125 Main body); 12(DM-300M)	√	√

Note: √ Standard Outfit, • Optional, \ Without this feature Trinocular microscope can be installed camera and screen.

Digital Microscope



BXTV-1



BXTV-1A



BXTV-1B



BXM-1B

Technical Parameters:

Specification	Model				
	BXTV-1	BXTV-1A	BXTV-1B	BXM-1B	
Viewing Head	Sliding Trinocular Head Inclined at 45°	√	√		
	Compensation Free Trinocular Head inclined at 30°			√	
	10" LCD				√
Nosepiece	Ball Beating Quadruple Nosepiece	√	√	√	√
Eyeiece	WF10X/18mm	√	√	√	√
Objective	Achromatic 4X, 10X, 40X(S)100X(S, O)	√	√		
	Plan Achromatic 4X, 10X, 40X(S)100X(S, O)			√	√
Stage	Double Layer Mechanical Stage 135*140mm	√	√	√	√
Condenser	ABBE NA1.25 condenser with Iris Diaphragm & filter, rack&pinion adjustable	√	√	√	√
Illumination	Build-in Illumination, Halogen lamp 6V/20W, Power supply 90-230V	√	√	√	√
Power Supply	AC110/220V±10%, 50/60Hz	√	√	√	√
Package	Cartoon with foam	√	√	√	√
Package Size	250*360*460mm	√	√	√	√
Gross Weight	8kg	√	√	√	√

Image Sensor	1/3 SONY CCD	Video Output	BNC 1.0VP-P.75
Signal System	PAL/NTSC	Backlight Compensation	OFF/ON
Scanning Frequency	Horizontal: 15.62KHz; Vertical: 50Hz	Electronic Shuttle	AUTO IRIS EE
Horizontal Resolution	480TV/520TV	Camera Interface	CS
Min Illumination	F1.2 0.5LUX; 0.01 LUX	Balance	Auto
Gain Control	Auto	Power	DC 12V
48S/N Ratio	50dB AGC		

Note: 110V/220V for LED lamp, 220V only for Halogen lamp

Optional: 2.0, 3.0 or 5.0 Megapixel, CMOS electronic eyepiece(only for Trinocular microscope)

Digital Biological Microscope



Technical Parameters:

Model	DM-18NS
View Head	Compensation free binocular head, Inclined at 30°, 360° rotatable, Interpupillary 55~75mm
Eyeiece	WF10X/22mm
Infinite Plan Achromatic Objective	4X, 10X, 40X(S), 100X(S,Oil)
Focusing	Coaxial Coarse & Fine Adjustable System, Range 30mm, Fine Division 0.002mm
Stage	Double Layers Mechanical Stage 180*150mm, Moving Range 75*50mm
Condenser	Abbe NA1.25 centerable condenser with Iris Diaphragm & Filter
Illumination	Halogen lamp 6V/20W, Kohler illumination, brightness adjustable
Filter	Blue, yellow, green
Imaging System	3M CMOS
Power Supply	AC85~265V, 50/60Hz
Package Size	380*300*580mm
Gross Weight	8.4kg

Build-in Camera Biological Microscope



BMB-117M



BMB-300M

Technical Parameters:

Model		BMB-117M	BMB-300M		
Viewing Head	Compensation Free Binocular Head, Inclined at 30°, Interpupillary Distance 48-75mm		√	√	
	Camera System	Valid Pixel	1280*1024(1.3M Pixel)	√	/
			1600*1200(2.0M Pixel)	●	/
			2048*1036(3.0M Pixel)	/	√
			2052*1944(5.0M Pixel)	/	●
		Output Mode	USB2.0	√	√
Operation System	WINDOWS7/8 2000 / XP/ VISTA	√	√		
Software	ScopelImage 9.0	√	√		
Range of Viewing Field	>90%(BMB-117M); 18mm(BMB-300M)	√	√		
Eyepiece	WF10×/18	√	√		
	P16×/11	●	/		
Objective	Extra wide filed eyepiece EW10×/20 with diopter adjustment	/	●		
	Achromatic Objective 4×, 10×, 40×, 100×	√	/		
	Infinite plan Achromatic Objective 4×, 10×, 40×, 100×	/	√		
	Infinite Plan Achromatic Phase Objective 10×,20×,40×,100×	/	●		
	Oil Darkfield Objective with Iris Diaphragm 100×(NA0.36-1.25)	/	●		
Nosepiece	Backward Quadruple Nosepiece	√	/		
	Quintuple Nosepiece	/	●		
	Quadruple Nosepiece	/	√		
Stage	Double Layers Mechanical Stage 140*140mm, Moving range 75*50mm	√	√		
Condenser	Abbe NA1.20 with Iris Diaphragm & Filter	√	/		
	Swing Condenser N.A.0.9/0.25	/	√		
	Turret Phase Contrast Condenser	/	●		
	Dark Field Condenser (Dry)	/	●		
Focusing	Dark Field Condenser (Oil)	/	●		
	Coaxial Coarse & Fine Adjustment System, Range 24mm, Fine Division 0.004mm	√	/		
Illumination	Coaxial Coarse & Fine Adjustment System, Range 20mm	/	√		
	LED 3W, Brightness Adjustable	√	/		
	Halogen Lamp 6V/20W, Brightness Adjustable	●	/		
Power Supply	S-LED Powerful Illumination	/	√		
	AC 110~220V, 50/60HZ	√	√		
	Phase Contrast Kit	●	●		
Accessories	Dark-Field Attachment	●	●		
	Polarization Attachment	●	●		
Package Size	396*262*492(BMB-117M), 334X334X533(BMB-300M)	√	√		
Gross Weight	7.5kg (BMB-117M), 12.5kg (BMB-300M)	√	√		

Note: √ Standard Outfit, ● Optional, \ Without this feature

Polarizing Biological Microscope



BMP-107B

Features:

With the features of easy operation, complete functions and economy, it is an ideal instrument in geology, petroleum, coal, chemicals and physic fields. It is also widely used in academic demonstration and scientific research.

Technical Parameters:

Model		BMP-107B	BMP-107T
Viewing Head	Sliding binocular head at 45°, 360° rotatable	√	\
	Sliding trinocular head at 45°, 360° rotatable	\	√
Eyepiece	Eyepiece WF10×/18 with scale of crosshair	√	√
	Eyepiece WF10×/18	√	√
Objective	Strain free achromatic objective 4×, 10×, 40×	√	√
Nosepiece	Toward quadruple nosepiece, center adjustable	√	√
Analyzer	Rotatable analyzer with gradation 0°~90°	√	√
Bertrand Lens	Bertrand lens, sliding in/ out of optical path	√	√
Optical Compensator	λ slip(first class red)	√	√
	1/ 4λ slip	√	√
	Quartz wedge	√	√
Revolving Round Stage	Diameter Φ160mm, graduated in1° increments, Minimum resolution 6' when using vernier scale	√	√
Condenser	Abbe condenser with Iris diaphragm & filter	√	√
Focusing	Coaxial coarse & fine adjustment, range 28mm, fine division 0.002mm	√	√
Polarizer	Sliding in/out of optical path, located on the top of collector	√	√
Illumination	6V/ 20W halogen lamp, brightness adjustable	√	√
Power Supply	AC 110~220V, 50/60HZ	√	√
Package Size	327*273*425mm	√	√
Gross Weight	7.5kg	√	√

Note: √ Standard Outfit, ● Optional, \ without this feature Trinocular microscope can be installed camera and screen.

Fluorescence Biological Microscope



Technical Parameters:

Model	BFM-31
Eyepiece	WF10×/22
View Head	Hinged Trinocular Viewing Head Inclined at 30°, Interpupillary 53-75mm
Objective	Infinite Plan Achromatic Objectives 4x,10x,40x,100x
Fluorescence Accessories	B(Blue) excitation light, 460-490nm
Focusing System	Coaxial Coarse and Fine Adjustment, Fine Division 2um, Coarse Stroke 40mm per Rotation, Fine Stroke 0.2mm per Rotation
Nosepiece	Backward Quadruple Nosepiece
Stage	Double Layers Mechanical Stage 210mmx140mm/ 76mmx50mm
Transmission Lighting System	NA1.25 Abbe Condenser LED light, adjustable
Camera Port	1XC
Power Supply	110-220V 50-60Hz
Packing Size	340*210*493mm
Gross Weight	15kg



Technical Parameters:

Model	BFM-43
Eyepiece	WF10×/25
View Head	Hinged Trinocular Viewing Head Inclined at 30°, Interpupillary 50-75mm
Objective	Plan semi-complex fluorescence objective 4x,10x,40x,100x
Fluorescence Accessories	FB-U-M: EX375nm, DM:415nm, EM:460nm FB-B-M: EX475nm, DM:505nm, EM:530nm FB-G-M: EX540nm, DM:600nm, EM:610nm
Nosepiece	5-hole converter Nosepiece
Stage	Double Layers Mechanical Stage
Transmission Lighting System	NA1.1 Abbe Condenser LED light, adjustable
Power Supply	110-220V 50-60Hz
Packing Size	540*275*500mm
Gross Weight	30kg

Fluorescence Biological Microscope



XY-1



XY-2

Technical Parameters:

Model	XY-1/XY-2
Viewing Head	Binocular head (XY-1), Trinocular head (XY-2)
Fluorescent Straight Illumination	B(Blue) or G(Green) exciting light filter system, and O ordinary light system. 100W HBO Super high-pressured spherical mercury lamp
Protection Screen	Screen to resist the UV
Power	AC input 220V
Connecting Wire	With 2 connectors
Fluorescent Free Objective	4X, 10X, 40X, 100X (Oil)
Immersion Oil	Fluorescent free oil
Power Supply	AC110/220V±10%, 50/60Hz
Package Size	320*270*425; 150*300*250
Gross Weight	7kg; 3kg

Note: 110V/220V for LED lamp

Optional: 6.3 or 20 Megapixel, COMOS electronic eyepiece, Ultraviolet, Violet exciting light filter system and ordinary light system. Auxiliary exciting filter EX450-490.



Technical Parameters:

Model	BFM-52
Eyepiece	WF10×/22
View Head	Trinocular Viewing Head Inclined at 45°, Interpupillary 53-75mm
Objective	Infinite Plan Achromatic Objectives 10x,20x,40x, Infinite Plan Achromatic Objectives Contrast 20x
Fluorescence Accessories	UV Excitation Light: 330-380nm B Excitation Light: 460-490nm G Excitation Light: 510-550nm
Focusing System	Coaxial Coarse and Fine Adjustment, Fine Division 2um
Nosepiece	5-hole Nosepiece
Stage	Double Layers Mechanical Stage 227mmx208mm/ 77mmx114mm
Transmission Lighting System	Push-pull plate phase contrast condenser LED light, adjustable
Camera Port	1XC
Power Supply	110-220V 50-60Hz
Packing Size	486*276*537mm
Gross Weight	28kg

Trinocular Inverted Microscope



BMI-37XC

BMI-37XE

Technical Parameters:

Model	BMI-37XC	BMI-37XE
Optical System	Infinite optical system	
View Head	Compensation free trinocular head, Inclined at 45°, 360° rotatable, Interpupillary 48~75mm	
Eyepiece	WF10X/22mm, P16X/20mm	P10X/20mm
Objective	Infinite LWD Plan Achromatic Objective	4X N.A=0.10 WD=25.00mm 20X N.A=0.40 WD=8.00mm 40X N.A=0.60 WD=3.30mm
	Infinite LWD Plan Phase Contrast Objective	10X N.A=0.25 WD=8.10mm 20X N.A=0.40 WD=4.80mm 40X(Optional)
		10X N.A=0.25 WD=4.27mm 20X N.A=0.40 WD=8.00mm(Optional) 40X N.A=0.60 WD=3.50mm(Optional)
		10X N.A=0.25 WD=8.10mm 20X N.A=0.40 WD=4.80mm 40X(Optional)
Focusing	Coaxial coarse & fine adjustable system, pinion and rack adjustable, fine division 0.002mm	
Stage	242*172mm, glass slide ø110mm, moving range 120*75mm	Culture dish plate 1: 86*129.5mm, Ø87.5mm round culture dish is adaptive Culture dish plate 2: 34*77.5mm, Ø68.5mm round culture dish is adaptive Culture dish plate 3: 57*82mm, Ø60mm round culture dish is adaptive
Condenser	ELWD Condenser with Iris Diaphragm & Filter, LWD 75mm	
Illumination	Halogen lamp 12V/30W, brightness adjustable	LED lamp, 9W, brightness adjustable
Power Supply	AC85~265V, 50/60Hz	
Package Size	655*305*630mm	650*430*600mm
Gross Weight	14kg	16kg

Inverted Biological Microscope



Technical Parameters:

Model	BMI-39XD
Optical System	Infinite optical system
View Head	Compensation Free Trinocular Head, Inclined at 45°, 360° rotatable, interpupillary 47~78mm
Eyepiece	WF10X/22mm
Infinite Plan Phase Achromatic Objective	4X N.A=0.30 WD=7.40mm
	20X N.A=0.45 WD=7.50~8.80mm
	40X N.A=0.60 WD=3.00~4.40mm
Focusing	Coaxial Coarse & Fine Adjustable System, Range 30mm, Fine Division 0.002mm
Stage	Three Layers Mechanical Stage 340*230mm, Moving Range 130*85mm
Condenser	ELWD condenser NA0.3, LWD 26mm
Illumination	Transmission illumination: Halogen lamp, 12V/100W, Kohler illumination Epi-illumination: 100w fluorescent mercury lamp
Filter	Blue, yellow, green
Power Supply	AC85~265V, 50/60Hz
Package Size	820*880*570mm
Gross Weight	32kg

Inverted Biological Microscope



Features:

- * Excellent optical function with infinite optical system.
- * Innovative stand structure, sharp image display, convenient operation and special design for viewing incubating cell tissue.

Technical Parameters:

Model	BMI-100		
Optical System	Infinite optical system		√
Viewing Head	Trinocular head inclined at 30°, interpupillary distance 48~75mm		√
Eyepiece	High-point, extra wide field eyepiece EW10×/ 22		√
Objective	LWD infinite plan objective	4×/ 0.1, WD 17.3mm;	√
		10×/ 0.25, WD 10mm;	●
		20×/ 0.4, WD 5.1mm;	●
		40×/ 0.6, WD 2.1mm	√
	Infinite plan phase objective	PH10×/ 0.25, WD 10mm;	√
		PH20×/ 0.4, WD 5.1mm;	√
		PH40×/ 0.65, WD 2.1mm	●
Nosepiece	Quintuple nosepiece		√
Condenser	ELWD condenser NA 0.3, LWD 72mm (without condenser 150mm)		√
Centering	Centering telescope (Φ30MM)		●
Phase Annulus	10×-20×, phase annulus plate (fixed)		√
	10×-20×, 40× phase annulus plate (adjustable)		●
Stage	Plain stage 160×250mm		√
	Glass insert		√
	Attachable mechanical stage, X-Y coaxial control, moving rang 120×78mm		●
	Auxiliary stages 70×180mm		√
	Terasaki holder		●
	Φ35mm petri dish holder		●
Focusing	Coaxial Coarse and Fine Adjustment, Fine Division 0.002mm, Coarse Stroke 37.7mm per Rotation, Fine Stroke 0.2mm per Rotation, Moving Range up 8mm, down 3mm		√
	Halogen lamp 6V/ 30W		√
	LED		●
Filter	Blue, green and ground glass, diameter 45mm		√
Power Supply	AC 110~220V, 50/60HZ		√
Accessories	Inverted flurescent attachment FL-100, photo attachment, video adapter with C mount		●
Package Size	468*397*665mm		√
Gross Weight	15.5kg		√

Note: √ Standard Outfit, ● Optional Trinocular microscope can be installed camera and screen.



Technical Parameters:

Model	BMI-202		
Optical System	Infinite optical system		√
Viewing Head	Seidentopf trinocular viewing head, Inclined at 45°, 360° rotatable, Interpupillary 48~75mm		√
Eyepiece	wide field eyepiece WF10×/22, eyepiece tube diameter 30mm		√
	Wide field eyepiece WF15×/16		●
	Wide field eyepiece WF20×/12		●
Objective	LWD infinite plan achromatic objective 4×/0.10 WD=22		√
	LWD infinite plan achromatic phase objective	10×/0.25 WD=6	√
		20×/0.4 WD=3.1	√
		40×/0.55 WD=2.2	√
	High-level phase contrast objective	10×/0.25 WD=6	●
		20×/0.4 WD=3.1	●
40×/0.55 WD=2.2		●	
	Lamp house adjustment objective		●
Nosepiece	Backward quintuple nosepiece		√
Condenser	ELWD condenser NA0.3, LWD72mm(without condenser 150mm)		√
Centering Telescope	Centering telescope(φ30mm)		√
Phase Annulus	10×, 20×, 40× phase annulus plate(adjustable)		√
Stage	Plain stage 230×170		√
	Glasse insert		√
	Attachable mechanical stage, X, Y coaxial control, moving rang 80×120mm		√
	Auxiliary stage		√
	Terasaki holder		√
	Petri dish holder φ38		√
	Petri dish holder φ54		√
Focusing System	Coaxial coarse and fine adjustment, fine division 0.002mm, moving range up 4.5mm down 4.5mm		√
Illumination	6V, 30W halogen lamp, brightness adjustable		√
Filter	Blue, green and ground glass, diameter 45mm		√
Power Supply	110~220V, 50/60Hz		√
Accessories	Photo attachment		●
	C Mount 0.4×		●
Package Size	630*350*620mm		√
Gross Weight	15kg		√

Note: √ Standard Outfit, ● Optional Trinocular microscope can be installed camera and screen.

Metallurgical Microscope



XJD-100



XJD-200



4XC

Technical Parameters:

	Specification	Model			
		XJD-100	XJD-200	XDS-1	4XC
Viewing Head	Monocular Head Inclined at 45°	√			
	Binocular Head Inclined at 45°		√		
	Sliding Trinocular Head Inclined at 45°			√	
	Binocular viewing head inclined at 30°				√
Nosepiece	Quadruple Nosepiece	√	√	√	√
Eyepiece	WF10X	√	√		
	WF10 X18mm			√	√
Objective	Achromatic Objective: 10 X, 100 X	√	√		
	LWD Plan Achromatic Objective:40 X				
	Achromatic Objectives 4X, 10X, 40X, 100X			√	
	LWD Plan Achromatic Objectives 10X, 20X, 40X, 100X				√
Stage	Double Layer Mechanical Stage 180*150mm moving range 15*15mm				√
	Double Layer Mechanical Stage 140*135mm moving range 70*50mm			√	
	Double layer mechanical stage 200*180mm, φ10 well table plate, φ20 well table plate	√	√		
Focusing	Coaxial coarse & fine focusing adjustment with rack and pinion mechanism fine focusing scale value 0.002mm	√	√	√	√
Illumination	Build-in Illumination, halogen lamp 6V/20W	√	√	√	√
Filter	Blue, Green, Yellow	√	√		√
Power Supply	AC 110~220V, 50/60Hz	√	√	√	√
Package Size(mm)		420*350*520		330*280*440; 370*260*470	400*300*450
Gross Weight(kg)		10		6.5; 5	11



Technical Parameters:

Model		MM-5000
Optical System	Infinite optical system	√
Extra Wide Field Eyepiece	EW10×/22	√
	EW10×/20 eyepiece with scale of cross hair	√
Field Eyepiece	EW15×/16	●
	EW20×/12	●
Infinite LWD Plan Achromatic Objective	5×/0.12/∞/0(BF/DF) LWD 10mm	√
	10×/0.25/∞/0(BF/DF) LWD 10mm	√
	20×/0.4/∞/0(BF/DF) LWD 5mm	√
	50×/0.75/∞/0(BF/DF) LWD 1.3mm	√
	100×/0.9/∞/0(BF/DF) LWD 0.7mm	√
Viewing Head	Siedentopf binocular viewing head, Inclined at 30°, Interpupillary 48~75mm	√
Kohler Incident Light	12V/50W halogen light, center and brightness adjustable	√
	Polarizer and analyzer	√
	DIC	●
	Built-in green, blue, yellow, gray and ground glass	√
Focusing	Coaxial coarse and fine adjustment, fine division 2μm,	√
Nosepiece	Backward quintuple nosepiece	√
Stage	Double layer mechanical stage 226×178mm, Moving range 40mm×40mm	√
	Stage Φ20, Φ30, teardrop	√
Accessories	Photo/Video attachment	●
	Micrometer scale 0.01mm	√
Power Supply	AC110/220V±10%, 50/60Hz	√
Package Size	730*350*550mm	√
Gross Weight	18kg	√

Note: √ Standard Outfit, ● Optional Outfit

Teaching Microscope



BBM-18F2



BBM-18F3



BBM-18F5

Technical Parameters:

Model	BBM-18F2	BBM-18F3	BBM-18F5
Optical System	Infinite optical system		
View Head	Compensation free binocular head, Inclined at 30°, 360° rotatable, Interpupillary 55~75mm		
Eyeiece	WF10X/22mm		
Infinite Plan Achromatic Objective	4X, 10X, 40X(S), 100X(S, Oil)		
Focusing	Coaxial Coarse & Fine Adjustable System, Fine Division 0.002mm		
Stage	Double Layers Mechanical Stage 180*150mm, Moving Range 75*50mm	Double Layers Mechanical Stage 180*160mm, Moving Range 80*50mm	
Condenser	Abbe NA1.25 centerable condenser with Iris Diaphragm & Filter		
Indicator	LED cursor indicator		
Illumination	Halogen lamp 6V/20W, Kohler illumination, brightness adjustable		Halogen lamp 12V/100W, Kohler illumination, brightness adjustable
Filter	Blue, yellow, green		
Power Supply	AC85~265V, 50/60Hz		
Package Size	360*280*565mm	505*380*580mm	Box 1: 715*555*210mm, 22kg Box 2: 355*275*625mm, 15kg Box 3: 335*225*445mm, 10kg
Gross Weight	12kg	19kg	

Stereo Zoom Microscope



SZM-EB2040C SZM-E2040C SZM-E40X SZM-E0745C SZM-E0745CS SZM-E0745CLT SZM-E0745CLTS

Technical Parameters:

Model	SZM-EB2040C	SZM-E2040C	SZM-E40X
Objective	2x Objectives	/	/
	4X Objectives	/	/
	2X&4X Objectives Can Convertible	√	/
Eyeiece	Wide Field Eyeiece: WF10X (WF20X optional)	√	√
	Binocular, tilted 45°Pupil distance 48-75mm	√	/
Viewing Head	Binocular, 90°Straight cylinder, Pupil distance 48-75mm	/	√
	φ60 black and white tabletop, slicing and pressing	/	√
Base	φ90 black and white tabletop, slicing and pressing, complimentary φ90 glass panels	260*380*20mm Large flat base	/
	No light source	√	√
Light Source	Upper light source	/	/
	Up and down light sources	/	√
Lighting	100-230V/12V5W LED	√	/
Package Size(W*D*H)mm	390*240*370	370*180*300	160*220*310
Gross Weight(kg)	4.5	3.2	1.7

Technical Parameters:

Model	SZM-E0745C	SZM-E0745CS	SZM-E0745CLT	SZM-E0745CLTS
Objective	0.7- 4.5X zoom objective	√	√	√
Eyeiece	Wide Field Eyeiece: WF10X (20mm) (WF20X optional)	√	√	√
	Binocular, tilted 45°Pupil distance 48-75	√	√	√
Viewing Head	90°straight tube, C-interface	/	/	/
	260*380*20mm	/	/	/
Base	200*255*22mm	/	/	/
	200*255*60mm	√	√	/
	205*275*40mm	/	/	√
Light Source	No light source	√	/	/
	Upper light source	/	/	√
	Up and down light sources	/	/	√
	Can optional LED circular light	√	√	√
Lighting	100-230V/ 12V5W LED	√(Optional: 220V/6V20W or 110V/6V20W halogen lamp)	√(Optional: 220V/6V20W or 110V/6V20W halogen lamp)	√
	Package Size(W*D*H)mm	515*268*380	515*268*380	510*360*295
Gross Weight(kg)	6.2	6.5	7	7.5

Stereo Zoom Microscope



Technical Parameters:

Model	Specifications	SZM-45	SZM-45T
Viewing Head	Binocular view head inclined at 60°	√	
	Trinocular view head inclined at 45°		√
	Digital view head inclined at 45°		√
Eyepiece	High point wide field adjustable eyepiece WF10X/20mm	√	√
Zoom Objective	0.67X~4.5X	√	√
Zoom Ratio	6.7:1	√	√
Auxiliary Objective	0.5X/177mm, 1.5X/47mm, 2X/26mm	√	√
Working Distance	115mm	√	√
Focusing Bracket	Focusing frame and adjustment knob	√	√
Interpupillary Distance	55~75mm/52~75mm	√	√
Up Illumination	LED lamp	√	√
Down Illumination	LED lamp	√	√
Power Supply	AC110/220V±10%, 50/60Hz	√	√
Package	Cartoon with foam	√	√
Package Size(W*D*H)	mm	500*260*370	
Gross Weight	kg	8	

Model	ST-20	ST-40	ST-60
Illumination	Natural light Binocular	Tranilluminator/Inclined light	Natural light
View Head And Body	Straight Head	Inclined viewing Up-rotatable body	Inclined viewing Body 360°rotatable
Objective	2X	2X&4X, 90°rotated	2X&4X, 360°rotated
Working Distance	80mm	57mm	100mm
Eyepiece	WF10X/20		
Power Supply	/	AC110/220V±10%, 50/60Hz	
Package Size(W*D*H)	300*200*150mm	360*170*290mm	400*250*360mm
Gross Weight	3kg	6kg	8kg

Note: 110V/220V for LED lamp, 220V only for Halogen lamp

Optional: SZM-45, SZM-45T: 2.0, 3.0 or 5.0 Megapixel, CMOS electronic eyepiece(only for Trinocular microscope) ;

ST-20, ST-40, ST-60: Fluorescent lamp



Technical Parameters:

Model	SZM-XTZD		
Eyepiece (Working distance 100mm)	10X, φ22mm	Magnification	Field diameter
		7X	28mm
	20X, φ10mm (Optional)	Magnification	Field diameter
		45X	4.3mm
Objective (Working distance 30mm)	2X (Optional)	Magnification	Field diameter
		14X	14.3mm
		90X	2.2mm
		Magnification	Field diameter
		28X	7.1mm
		180X	1.1mm
Magnification	7~45X		
Interpupillary Distance	55mm~75mm		
Focusing Bracket	Hole, φ76mm		
Slide Focusing Range	60mm		
Working Distance	235mm		
Light Source	12V 3W, LED light		
Stage	Glass stage, φ95mm		
Base Size	Size: 275mm*205mm, thickness: 33mm		
Power Supply	AC100~240V, 50/60Hz		
Package Size (W*D*H)	490*415*330mm		
Gross Weight	8kg		

Sample Pre-Processing Semi Automated Plate Sealer

Application:

The Semi-Automated Plate Sealer is used for sealing a wide variety of microplates (Elisa, cell culture, PCR and deep-well plates) to store samples, prevent evaporation and minimize contamination. It is applicable for a variety of heat seals, meeting any laboratory application, including PCR, colorimetric, fluorescence, long term storage. A plate sensing system allows to provide uniform force, transferring heat evenly to the sealing surface whether using PCR plates or deep-well plates.

Features:

- * Rapid heating(reaching 170C in 300seconds)
- * Adjustable Sealing Temperature: 80°C ~170°C
- * OLED display screen, high light.
- * Applicable for different micro plates and heat seals.
- * Precise temperature, timing and pressure for consistent sealing.
- * Compact footprint: only 178mm wide x 370mm depth



Technical Parameters:

Model	BK-PS1000
Display	OLED
Temperature Accurate	±1°C
Seal Time	0.5s~10s(increment of 0.1s)
Seals Plate Heights	9~48mm
Compatible Plate Materials	PP(Polypropylene); PS(Polystyrene); PE(Polyethylene)
Compatible Plate Types	Standard Assay Plates Deep-well Storage Plates PCR Plates: skirted, semi-skirted, non-skirted
Power	300W
Compatible Sealing Film Types	Foil-polypropylene laminate Clear polyester-polypropylene laminate Clear polymer Thin clear polymer
Sealing Temperature	OFF, 80°C~200°C (increment of 1.0°C)
Power Supply	220V, 50/60Hz;110V, 60Hz
Standard Blocks	Deep hole plate /ELISA plate adapters;96-hole microtiter plate adapter
Optional Blocks	384 hole microtiter plate adapter
External Size(W*D*H)mm	370*178*330
Package Size(W*D*H)mm	420*270*460
Net/Gross Weight(kg)	12/13

Microplate Incubator



Introduction:

The microplate incubator adopts micro-processing technology combined with PID control method, which has the advantages of small size, light weight, and no pollution; LCD displays temperature and time, and is easy to operate. Mainly used for incubation of ELISA plates (96-well/384-well plates), 96-well cell culture plates, etc.

Features:

- * Powder-coated steel shell, sturdy and durable.
- * Adopt intelligent fuzzy PID control and double-layer heating system to ensure the stability and accuracy of temperature.
- * With Fahrenheit and Celsius switching function.
- * Timing mode, timing mode, timing unit are all selectable.
- * With temperature self-tuning function, 2 interval PID control, 3 stage temperature slope correction.
- * With lock screen function, password unlock.
- * With temperature sensor failure alarm prompt, the controller automatically cuts off the heating output.

Technical Parameters:

Model	BJPX-DH2	BJPX-DH4
Temp. Control Range	RT.+5°C~90°C	
Timing Range	1~ 9999hour/minute	
Temp. Accuracy	≤±0.5°C	
Display Accuracy	0.1°C	
Temp. Uniformity	≤±0.5°C	
Heating Time	≤10min (from RT. to 80°C)	
Capacity	2pcs microplates or culture plates	4pcs microplates or culture plates
Power Supply	AC100V~245V 50/60Hz	
Dimension (mm)	250*300*200	250*430*200
Net Weight (kg)	6.5	12
Package Size (mm)	310*360*260	310*500*260
Gross weight (kg)	10	16

Microplate Shaker

Features:

- * Open tray and sample access are more convenient.
- * Small volume, large processing capacity.
- * Adjustable speed and timer.
- * Brushless DC motor.



Technical Parameters:

Model	BK-VX1800
Motor Type	DC motor
Shaking Amplitude & Type	3mm, Horizontal rotation
Rotary Range	200~1800rpm
Plate Type	Elisa plate, cell culture plate, deep hole plate
Timing Range	0~100h
Module Material	Sponge
Control Type	Digital display panel, key control
Ambient Condition	5~40°C, 80% RH
Rated Power	20W
Power Supply	AC100~240V, 50/60Hz
External Size	420*305*147mm
Net Weight	16kg
Packing Size	492*382*219mm
Gross Weight	19kg

Features:

- * LCD display system status and parameters.
- * Stable and reliable shaking.
- * Easy to operate with one touch knob.
- * Automatic fault detection and buzzer alarm function.
- * 12-month warranty.



Technical Parameters:

Model	BK-TS100
Time Range	1min~99h59min
Mixing Orbit	3mm
Sample Capacity	4plates
Speed Range	200~1500rpm
Speed Step Value	10rpm
Consumption	45W
Power Supply	AC110~240V, 50/60Hz
Dimension	280*270*140mm
Packing Size(W*D*H)	440*360*260mm
Weight	4.0kg
Gross Weight	6.5kg

Denaturation & Hybridization System



Features:

- * This instrument is adopted FISH processing step, which can reduce a lot of manual operating time and avoid the damage of harmful reagent.
- * Full touch screen operation, friendly human interface.
- * Support restart functionality runs an unexpected power outage, when power is restored can be scheduled to automatically back up and running.
- * Supporting automatic cooling function after running over.
- * Supporting automatic warm-up function.
- * Platform high precision of temperature control, low fluctuation.
- * Can deal with 12 slides.
- * Support 105 custom programs stored functions.
- * Integrated denaturation and hybridization, hybrid, multiple-step operation three modes of operation.

Technical Parameters:

Model	BK-DH2000
Temperature Control Range	RT+5°C~100°C
Temperature Setting Range	0°C~100°C
Capacity	12 Slides
Temperature Accuracy	±1°C
Temperature Uniformity	±1°C
Timing Range	1min~99h59min
Heating Time(37°C to 95°C)	≤2min
Cooling Time(95°C to 45°C)	≤6min
Power	350w
Power Supply	220V, 50/60Hz; 110V, 60Hz
External Size(L*W*H)	440*220*120mm
Packing Size(W*D*H)	580*370*300mm
Gross Weight	7kg

Thermo Shaker Incubator



Features:

- * LCD display. It is easy to setup and use.
- * Reliable design with inner extra temperature protection.
- * Each thermo shaker is equipped with lifter that is easy to replace different blocks.
- * Digital accuracy and convenience.
- * Precision wells for uniform thermal transfer.
- * Assorted blocks for a wide variety of tube sizes.
- * Brushless DC Motor: noiseless long service life maintenance-free.
- * Conform to CE safety standard.
- * Accurately control and display time, temperature and speed.

Technical Parameters:

Model	BK-TS110	Model	BK-TS110
Temperature Setting Range	0°C~100°C	Auto Heating	Yes
Temperature Control Range	RT-20°C~100°C	Auto Resume To Run	Yes
Timing Range	1min~99h59min/∞	Power Supply	150w
Temperature Accuracy	±0.3°C	Fuse	250V 3A Φ5×20
Temperature Uniformity	±0.3°C	Heating Time	≤15min(from 25°C to 100°C)
Shaking Speed	200rpm~1500rpm	Cooling Time	≤10min(from 100°C to 25°C)
Orbit	3mm		≤20min(from RT to RT-20°C)
Multi Point Running	Yes (Max 5points)	Voltage	AC110~220V/50~60Hz
Multi Cycle	Yes (Max 99times)	Dimension	260*195*150mm
Auto Running	Yes	Packing Size(W*D*H)	410*320*310mm
Storage At 4°C	Yes	Gross Weight	9.5kg

Optional Blocks:

Type	Test Tube Diameter	Type	Test Tube Diameter
B30	96*0.2ml	B36	24*5ml
B31	54*0.5ml	B37	15*10ml
B32	35*1.5ml	B38	12*15ml
B33	35*2.0ml	B39	6*50ml(round-shape bottom)
B34	15*0.5ml+20*1.5ml	B39-S	6*50ml(cone-shape bottom)
B35	96*0.2ml(elisa plate)		



It is mainly used in small constant temperature experiments. The two functions of constant temperature and shaking, which greatly reduces the experimental operation time, and can be used for the preservation of samples of various analytical instruments.

Features:

- * Transparent cover for easy observation and protection against experimental error.
- * Fast cooling speed, high stability of temperature control.
- * A variety of standard sample modules are available to choose from, easy to replace. Modules can be customized.
- * LCD display, menu-type operation interface, multiple groups of data on one screen display, easy to operate.
- * It is controlled by microprocessor to ensure superior temperature stability and uniformity.

Technical Parameters:

Model	BJPX-DBP1
Display	3.5 inch LCD touch screen
Temp setting range	0°C-100°C
Temp control range	RT-100°C
Temp control accuracy	±0.3°C
Temp uniformity	±0.3°C
Display accuracy	0.1°C
Timing range	1~99h59min
Horizontal amplitude	2mm
Warming time	≤12 minutes (25°C to 100°C)
Cooling rate 1	≤10 minutes (100°C to 25°C)
Cooling rate 2	≤15 minutes (cooling to 20°C below room temperature)
Power	AC220V/50Hz 150W
Size	340mm*220*165mm
Test conditions: Room temperature 25±2°C, 1.5ML*35 well module, thermometer accuracy ±0.1°C.	

Dry Bath Incubator



Features:

- * LCD display, real-time temperature display and countdown display.
- * A variety of heating aluminum blocks can be flexibly replaced, making it more widely used and easy to clean and disinfect.
- * Automatic fault detection and alarm function.
- * Temperature deviation calibration function.

Technical Parameters:

Model	BJPX-DB1	BJPX-DB2	BJPX-DB4
Block Quantity	1	2	4
Temp. Control	PID microprocessor controller		
Temp. Range	RT+5°C-160°C		
Temp. Accuracy	±0.5°C (at 40°C)		
Temp. Uniformity	±1.0°C (at 40°C)		
Display Accuracy	0.1°C		
Timing Range	1~9999 mins or continuous operation.		
Heating Time	≤20 mins (30°C to 130°C); ≤30 mins (30°C to 160°C)		
Material	The Cover: Acrylic. External: Cold-rolled steel with anti-bacteria powder coating		
Standard Block	DB005*1pcs	DB005*2pcs	DB005*4pcs
Power Supply	220VAC±10% or 110VAC±10%; 50/60Hz		
External Size (W*D*H)	310*220*190 mm	380*260*200mm	502*260*200mm
Package Size (W*D*H)	360*280*240mm	555*320*250mm	
Net/Gross Weight	3.5/5kg	8/10kg	10/12kg

Optional Blocks:

No	Tube Diameter	Max Number of Tubes	No	Tube Diameter	Max Number of Tubes
DB001	0.2ml centrifugal tube	96	DB008	φ16mm	15
DB002	φ6mm	50	DB009	φ18mm	12
DB003	0.5ml centrifugal tube	40	DB010	φ20mm	8
DB004	φ10mm	28	DB011	φ26mm	6
DB005	1.5ml centrifugal tube	28	DB012	mixed sizes 1	6*φ13mm+8*φ10mm; 10*φ6mm+1*φ25mm
DB006	2.0ml centrifugal tube	28	DB013	mixed sizes 2	14*φ11mm; 14*φ12mm
DB007	φ13mm	24	DB014	mixed sizes 3	Customized



BK-HW100D



BK-HW100



BK-HW100G

Introduction:

Dry bath incubator is a product controlled by a microcomputer and manufactured with semiconductor refrigeration technology or heating film technology. The instrument can be configured with a variety of modules, which can be widely used in sample storage, storage and reaction of various enzymes, denaturation treatment of nucleic acids and proteins, PCR reaction, pre-denaturation of electrophoresis and serum coagulation, etc.

Features:

- * Microcomputer controller, high stability and precision.
- * LCD display, simple interface. Easy to set up and use.
- * Different kinds of modules are available.
- * Over-heating protection device, safe and reliable.
- * Multi periods program control, programmable.
- * Automatic fault detection and buzzer alarm function.
- * Temperature deviation calibration function.

Optional Module BK-HW100D/100:

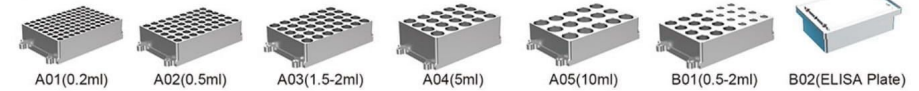

Optional Module BK-HW100G:

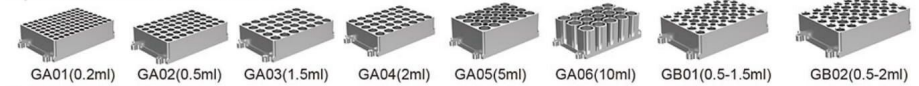

Technical Parameters:

Model	BK-HW100D	BK-HW100	BK-HW100G
Temp Setting Range	RT + 5°C-105°C	0°C-100°C	0°C-100°C
Temp Control Range	RT + 5°C-100°C	0°C-100°C	5°C-100°C(TEC)
Time Setting Range	1 min-99h59min		
Temp Fluctuation	±0.5°C		
Module Temp Uniformity	±0.5°C		
Temp Control Accuracy	±0.3°C		
Temp Display Accuracy	0.1°C		
Heating Rate	≤12min (20°C-100°C)	≤15min (20°C-100°C)	
Cooling Speed	/	≥8°C/min (from 100°C to 25°C)	
	/	≥1.3°C/min (from RT to RT-20°C)	
Temp Deviation Correction	Yes		
Program Setting	5 program periods		
Shaking Speed	/		
Storage	10 programs		
Alarm	Power-on self-test, over-temperature protection, fault alarm		
Consumption	150W		
Power	Standard: AC220V, 50/60Hz; Optional: AC110V, 50/60Hz		
Standard Module	B01*1(0.5-2ml)		GB01*1(0.5-1.5ml)
Package Size(mm)	375*290*310		
Gross Weight(kg)	6	8.5	10.5

Dry Bath Incubator

Application:

DBI-3 is microprocessor controlled Dry Bath Incubator. Instead of traditional water bath device, the heat-conducting medium is high purity aluminium. The exact desired temperature is easily set using the arrow keys on the sloped control panel while values are shown on the large digital display. No checking of a thermometer and readjusting temperature is necessary. The user calibration feature allows for easy calibration to in house standards when required. This product can be widely used in preservation and reaction of samples, DNA amplification, electrophoresis denaturation and serum solidification, etc.



Features:

- * LCD display.
- * Automatic fault detection and buzzer alarm function.
- * Electronic calibration. User can reset to any local standard.
- * Easy replacement and cleaning of block.
- * Built-in over-temperature protection.
- * Customized modules are accepted.

Technical Parameters:

Model	DBI-3	Model	DBI-3
Temp Setting Range	0°C~100°C	Auto Heating	Yes
Temp Control Range	RT+5°C~100°C	Auto Resume To Run	Yes
Time Range	1min ~ 99h59min/∞	Capacity	See optional block
Temp Accuracy	±0.3°C	Power	150W
Display Accuracy	0.1°C	Power Supply	220V, 50/60Hz; 110V, 60Hz
Temp Uniformity	±0.3°C	Fuse	250V 3A Φ5*20
Heating Time	≤12min(from 25°C to 100°C)	Dimension	260*195*150mm
Multi Points Running	Yes (Max 5 points)	Weight	2.5Kg
Multi Cycle	Yes (Max 99 times)	Package Size	410*320*310mm
Auto Running	Yes	Gross Weigh	3.5kg

Optional Blocks:

Type	Description	Type	Description
B30	96*0.2ml PCR plate	B36	24*5ml centrifuge tube
B31	54*0.5ml centrifuge tube	B37	15*10ml centrifuge tube
B32	35*1.5ml centrifuge tube	B38	12*15ml centrifuge tube
B33	35*2.0ml centrifuge tube	B39	6*50ml centrifuge tube(round-shape bottom)
B34	20*1.5ml+15*0.5ml	B39-S	6*50ml centrifuge tube(cone-shape bottom)
B35	96*0.2ml elisa plate		Choose one as a standard block.

Application:

DBI-10C is microprocessor controlled Dry Bath Incubator. Instead of traditional water bath device, the heat-conducting medium is high purity aluminium. The exact desired temperature is easily set using the arrow keys on the sloped control panel while values are shown on the large digital display. No checking of a thermometer and readjusting temperature is necessary. The user calibration feature allows for easy calibration to in house standards when required. This product can be widely used in preservation and reaction of samples, DNA amplification, electrophoresis denaturation and serum solidification, etc.



Features:

- * Energy-efficient Peltier design.
- * Automatic fault detection and buzzer alarm function.
- * Electronic calibration. User can reset to any local standard.
- * Small, compact size uses very little bench space.
- * Easy replacement, cleaning and disinfecting of metal blocks.
- * Built-in over-temperature protection.
- * Customized modules are accepted.
- * Buzzer alarm when temperature control ends.

Technical Parameters:

Model	DBI-10C	Multi Cycle	Yes (Max 99 times)
Temp Setting Range	-10°C~100°C	Auto Running	Yes
Temp Control Range	RT- 30°C~100°C	Auto Heating	Yes
Time Range	1min ~ 99h59min/∞	Auto Resume To Run	Yes
Temp Accuracy	±0.3°C	Capacity	See optional block
Display Accuracy	0.1°C	Power	150W
Temp Uniformity	±0.3°C	Power Supply	AC100~240V, 50/60Hz
Heating Time	≤10min(from 25°C to 100°C)	Fuse	250V 3A Φ5*20
Cooling Time	≤10min(from 100°C to 25°C)	Dimension	260*195*150mm
Cooling Time	≤25min(from RT to RT-30°C)	Weight	4.5Kg
Storage At 4°C	Yes	Package Size	410*320*310mm
Multi Points Running	Yes (Max 5 points)	Gross Weight	5.5kg

Optional Blocks:

Type	Description	Type	Description
B30	96*0.2ml PCR plate	B36	24*5ml centrifuge tube
B31	54*0.5ml centrifuge tube	B37	15*10ml centrifuge tube
B32	35*1.5ml centrifuge tube	B38	12*15ml centrifuge tube
B33	35*2.0ml centrifuge tube	B39	6*50ml centrifuge tube(round-shape bottom)
B34	20*1.5ml+15*0.5ml	B39-S	6*50ml centrifuge tube(cone-shape bottom)
B35	96*0.2ml elisa plate		Choose one as a standard block.

Dry Bath Incubator

Application:

The product is controlled by microcomputer, use high purity aluminum material as a heat conduction medium instead of the conditional water bath device, which is easy to use, wide temperature range, high precision and etc. It can be widely used in the sample preservation, reaction of DNA amplification, electrophoresis, degeneration, solidification and other kinds of serum biochemical sample thermostatic incubation process.



DBI-1001



DBI-1002

Features:

- * Real-time temperature display, the countdown display.
- * Convenient block replacement, easy to clean and disinfect.
- * Automatic fault detection and alarm function.
- * Built-in over temperature protection device.
- * Temperature deviation calibration function.

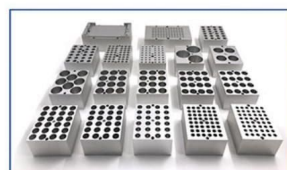

Technical Parameters:

Model	DBI-1001	DBI-1002
Temperature Range	RT.+5°C~160°C	RT.+5°C~160°C
Temp Accuracy	±0.5°C(@40°C)	
Temp Accuracy	±1°C(@120°C)	
Temp Uniformity	±0.5°C	
Display Accuracy	0.1°C	
Time Range	1-99h59min/∞	
Heating Time	≤15min(from 25°C to 160°C)	≤15min(from 25°C to 160°C)
Block Quantity	1	2
Max Power	300W	500W
Voltage	AC220V or AC110V, 50/60Hz	
Size	260*220*100mm	260*220*100mm
Weight	5.0kg	5.5Kg
Package Size	360*310*230mm	
Gross Weight	6kg	

Optional Blocks:

Model	Tube Diameter	Tube Quantity	Model	Tube Diameter	Tube Quantity
B01	6mm	48	B10	26mm	8
B02	7mm	48	B11	28mm	4
B03	10mm	24	B12	40mm	3
B04	12mm	24	B13	0.2ml centrifuge tube	48
B05	13mm	24	B14	0.5ml centrifuge tube	48
B06	15mm	16	B15	1.5ml centrifuge tube	24
B07	16mm	16	B16	2.0ml centrifuge tube	24
B08	19mm	12	B17*	0.2ml PCR plate	96
B09	20mm	12	B18*	0.2ml Elisa plate	96

B17/B18 block is only used for DBI-1002

Application:

DBI-M is a microprocessor-controlled product. It is widely used in preservation and reactions of sample, DNA amplification and initial denaturation of electrophoresis and so forth. It fits almost anywhere and can even be used in cars, boats or wherever a 24 volt power source is available.



Features:

- * Energy-efficient design.
- * Applicable to 24V / 12V power adapter.
- * Accurate to ± 0.3°C.
- * Process of experiment is visible.
- * Electronic calibration. User can reset to any local standard.
- * Custom blocks made to fit any sample holder.

Technical Parameters:

Model	DBI-M
Temp. Range	RT+5°C~100°C
Timing Range	1min~99h
Temp. Accuracy	≤±0.3°C
Display Accuracy	0.1°C
Temp. Stability	±0.3°C
Heating Time	≤20min(from 40°C to 100°C)
Voltage	DC24V/1.67A
Power	40W
Dimensions	145*113*110mm
Weight	0.5kg
Package Size	280*240*210mm
Gross Weight	1.7kg

Optional Blocks:

Type	Description
Mini A	15*2.0ml
Mini B	15*1.5ml
Mini C	24*0.5ml
Mini D	32*0.2ml

Choose one as a standard block.

Sample Concentrator

Features:

- * High precision and wide range of temp control.
- * Blowing a large number of samples at one time.
- * Blowing each sample independently.
- * Amount of airflow can be adjusted.
- * Easy operation; safe and reliable to use.
- * 12-month warranty.



Technical Parameters:

Model	BK-SC100
Temp. Control Range	RT.+5°C-160°C
Temp. Uniformity	±0.5°C
Display Accuracy	0.1°C
Heating Time	≤15min (from 25°C to 160°C)
Max Gas Usage	15L/min
Max Gas Pressure	0.02Mpa(Gas pin≤16pcs); 0.05Mpa (Gas pin>16pcs)
Max Power	300W
Dimension	260*220*450mm
Temp. Accuracy	±0.5°C (@40°C)
Temp. Accuracy	±1°C (@120°C)
Timing Range	1-99h59min/∞
Max Vertical Travel	200mm
Needle Length	150mm
Block Quantity	1
Voltage	220V, 50/60Hz; 110V, 60Hz
Packing Size(W*D*H)	430*420*340mm
Weight(kg)	7.0
Gross Weight(kg)	9.0

Optional Blocks:

Type	Test Tube Diameter	Capacity
B03	10mm	24
B04	12mm	24
B05	13mm	24
B06	15mm	16
B07	16mm	16
B08	19mm	12
B09	20mm	12
B10	26mm	8
B11	28mm	4
B12	40mm	3
B15	1.5ml(centrifuge tube)	24
B16	2.0ml(centrifuge tube)	24

Choose one as a standard block.

Sample Concentrator(visible)

Features:

- * High precision and wide range of temp control.
- * Blowing a large number of samples at one time.
- * Blowing each sample independently.
- * Amount of airflow can be adjusted.
- * With special slotting-design block, surface location of.
- * Concentrated samples can be observed.
- * Easy operation; safe and reliable to use.



Technical Parameters:

Model	BK-SC400
Temp. Control Range	RT.+5°C-160°C
Temp. Uniformity	±0.5°C
Display Accuracy	0.1°C
Heating Time	≤15min (from 25°C to 160°C)
Nitrogen Flow Rate	15L/min
Nitrogen Rressure	0.1Mpa
Max Power	500W
Dimension	260*220*475mm
Temp. Accuracy	±0.5°C (@40°C)
Temp. Accuracy	±1°C (@120°C)
Timing Range	1min-99h59min/∞
Needle Length	150mm
Block Quantity	1
Voltage	220V, 50/60Hz;110V, 60Hz
Packing Size(W*D*H)	430*420*340mm
Weight(kg)	7.3
Gross Weight(kg)	10.0

Optional Blocks:

Type	Diameter	Depth	Capacity
B02 027 001	10.5mm	50mm	12
B02 027 002	12.5mm	50mm	12
B02 027 003	13.5mm	50mm	12
B02 027 004	15.5mm	50mm	12
B02 027 005	16.5mm	50mm	12
B02 027 006	19.5mm	50mm	12
B02 027 007	20.5mm	50mm	12

Choose one as a standard block.

Ultrasonic Cell Disruptor

Application:

Widely used in the field such as biology, chemistry, microbiology, pharmacology, physics, zoology, agronomy, medical science, pharmacy for teaching, scientific research and production.

Features:

- * LCD touch screen display.
- * Storage capacity: 20 groups of program data.
- * Temp. monitor: over-temperature protection.
- * Other functions: automatic tracking the frequency, fault alarm.



Technical Parameters:

Model	UCD -150	UCD -250	UCD -500	UCD -650	UCD -950	UCD -1200	UCD -1500	UCD -1800	UCD -2000
Frequency(KHz)	20~25	20~25	20~25	20~25	20~25	19.5~20.5	19.5~20.5	19.5~20.5	19.5~20.5
Crushing Capacity(ml)	0.1~150	0.1~300	0.1~400	0.1~500	0.1~700	1~1000	1~1500	1~1200	50~2000
Standard Amplitude-change Pole Ø (mm)	6					20	22	22	25
Optional Amplitude-change Pole Ø(mm)	2, 3, 6, 8, 10	2, 3, 6, 8, 10	2, 3, 6, 8, 10, 12	2, 3, 6, 8, 10, 12	2, 3, 6, 8, 10, 12, 15	3, 6, 10, 15, 22, 25	10, 15, 20, 22, 25	10, 15, 20, 22, 25	10, 15, 20, 25
Consumption (W)	1.5~150	2.5~250	5~500	6.5~650	10~1000	12~1200	15~1500	18~1800	0~2000
Power Supply	AC220V±10%, 50/60Hz(Standard); AC110V, 60Hz(Optional)								
Package Size (W*D*H)	350*350*550mm(acoustic chamber) 470*305*430mm(main body)								
Gross Weight	26kg					29kg			

Technical Parameter for Amplitude Pole:

Size	Crushing Capacity(ml)	Recommended power ratio	Frequency (KHz)	UCD -150	UCD -250	UCD -500	UCD -650	UCD -950	UCD -1000	UCD -1200	UCD -1500	UCD -1800	UCD -2000
φ2mm	0.1-5ml	1~35%	20-25	√	√	√	√	√	√	√	×	×	×
φ3mm	3-10ml	1~45%	20-25	√	√	√	√	√	√	√	√	√	×
φ5mm	5-100ml	1~60%	20-25	×	×	×	×	×	×	×	×	×	×
φ6mm	10-100ml	1~70%	20-25	√	√	√	√	√	√	√	√	√	√
φ8mm	20-200ml	1~85%	20-25	√	√	√	√	√	√	√	√	√	√
φ10mm	30-300ml	1~90%	20-25	√	√	√	√	√	√	√	√	√	√
φ10mm	30-300ml	1~60%	19.5-20.5	×	×	×	×	×	×	×	√	√	√
φ12mm	50-600ml	10~90%	20-25	×	×	√	√	√	√	×	×	×	×
φ15mm	200-750ml	10~95%	20-25	×	×	×	×	√	√	×	×	×	×
φ15mm	50-500ml	5~80%	19.5-20.5	×	×	×	×	×	×	√	√	√	√
φ20mm	100-1000ml	10~90%	19.5-20.5	×	×	×	×	×	×	√	√	√	√
φ22mm	200-1200ml	20~95%	19.5-20.5	×	×	×	×	×	×	√	√	√	√
φ25mm	300-1500ml	30~95%	19.5-20.5	×	×	×	×	×	×	×	√	√	√

Continuous Flow Ultrasonic Cell Disruptor

Application:

It is suitable for the extraction of Chinese herbal medicine, cells, bacteria and emulsifying chemical nanometer material, suitable for small batch production or to provide accurate technical parameters for the future industrial production.

Features:

- * LCD Display
- * Automatic tracking the frequency
- * Storage capacity: 20 groups of program data.
- * It can test and control temperature of the sample
- * Function of automatic feeding and computer control can be optional equipped



Technical Parameters:

Model	UCD-4000W-II
Frequency	19.5~20.5KHz
Standard Amplitude-change Pole Ø	40mm
Crushing Capacity/Once	500~1000ml
Crushing Capacity/Continuously	100L/Day
Max. Consumption	1000~4000W, Adjustable
Time Set	Optional: Continuous/Pulse
Max. Working Time	99h59min59sec
Safety System	Over temperature; Time; Overload; No load
Standard Accessories	Main machine, energy converter, standard amplitude, sound proof box(or supporting frame)
Optional Accessories	Stainless steel reactor, peristaltic pump, low temperature water tank
Power Supply	AC220V±10%, 50/60Hz(Standard); AC110V, 60Hz(Optional)
Package Size(W*D*H)	675*305*450mm(main body); 430*415*730mm(soundproof box)
Gross Weight	32kg

Portable Ultrasonic Cell Disruptor

Features:

- * LCD Display
- * Temperature alarm setting range: 0~100°C
- * Ultrasonic time setting for on and off: 0.1-9.9s
- * Audible alarm for: Over temperature, over power, over time



Technical Parameters:

Model	UCD-P01
Frequency(KHz)	20~30, frequency automatic tracking
Crushing Capacity(ml)	0.1~150ml (need to choose the corresponding horn)
Standard Amplitude Pole Ø(mm)	3 or 5
Optional Amplitude Pole φ (mm)	2, 3, 5, 6
Other Optional Accessories	Foot switch, sound proof box, bracket
Consumption(W)	2.5~250W, adjustable
Power Supply	AC220V±10%, 50/60Hz(Standard); AC110V, 60Hz(Optional)
Package Size(W*D*H)	470*305*430mm(main body); 350*350*550mm(soundproof box)
Gross Weight	16(main body); 10(soundproof box)

Disintegrator

Plant Disintegrator



Features:

- * Grind by the action of rotating disk and fixed disk; the ideal equipment for grinding oiliness and fiber products.
- * Featured by lightweight, small volume, compact structure, continuous working time, attractive appearance and high efficiency. Space between blades is adjustable according to material fineness.

Technical Parameters:

Model	MPD-102
Mesh Size (mm)	0.5/1/1.5
Working Time	Continuous
Grinding (Mesh)	60~120
Speed (rpm)	1400rpm
Consumption	180W
Power Supply	AC110/220V±10%, 50/60Hz
External Size(W*D*H) mm	300*185*280
Package Size(W*D*H) mm	465*240*290
Net Weight(kg)	11.3
Gross Weight(kg)	19.5

High-speed Universal Disintegrator



HSD-80



HSD-100/200



HSD-400A

Technical Parameters:

Model	HSD-80	HSD-100	HSD-200	HSD-400A
Speed (rpm)	10000	26000	26000	26000
Size of Grinding Room (mm)	Ø80*40	Ø100*40	Ø125*56	Ø150*80
Grinding (mesh)	40~200			
Input Quantity (≤G/time)	50	100	200	400
Consumption	200W	800W	800W	1000W
Power Supply	AC220V, 50Hz			
External Size(W*D*H) mm	Ø110*210H	Ø160*320H	Ø160*360H	230W*190D*420H
Net Weight(kg)	2.5	4	5	13
Gross Weight(kg)	3	5	6	14

Ball Mill

Vertical Planetary Ball Mill(Semi-circle Type)

Application:

Planetary Ball Mill has four ball grinding tanks installed on one turntable. When the turntable rotates, the tank axis makes planetary movements, the balls and samples inside the tanks are impacted strongly in high speed movement, and samples are eventually ground into powder. Various kinds of different materials can be ground by the mill with dry or wet method. Minimum granularity of ground powder can be as small as 0.1 μ m.



Features:

- * 3D curve shape design.
- * Special gear with low noise.



Visual Window



Planetary Mechanism



Frequency Converter Control



Hole of Cooling Fan

Technical Parameters:

Model	BKBM-V0.4	BKBM-V2
Capacity	0.4L	2L
Volume of Each Capacity	50~100ml	50~500ml
Pot Quantity	4 pcs	
Running Time Range	1~9999min	
Reciprocal Running Time	1~999min	
Adjustable Speed	Revolution 45~435rpm	35~335rpm
Speed	Rotation 90~870rpm	70~670rpm
Noise	58 \pm 5dB	60 \pm 5dB
Speed Control Mode	Frequency Control	
Transmission Mode	Gear Drive	
Working Mode	2 or 4 pots can be used each time	
Maximum Sample Volume (material + grinding ball)	2/3 of the volume of the ball mill tank	
Feed Size	Soft and Crispy material<10mm, Other materials<3mm	
Out-put Granularity	Minimum Granularity can be reached to 0.1 μ m	
Adjusting Mode of Rotate Speed	Frequency converter with stepless speed regulation	
Consumption	0.25KW	0.75KW
Power Supply	AC110/220V \pm 10%, 50/60Hz	
External Size(W*D*H)mm	530*300*340	750*470*565
Package Size(W*D*H)mm	595*360*485	820*530*720
Net Weight(kg)	29	80
Gross Weight(kg)	50	100
Note: Both pot and ball are optional. For a ball mill with a capacity of 2L, if the matching mill pot specification is 25ml or 50ml, you need to purchase a base holder separately.		

Vertical Planetary Ball Mill(Square Type)



Features:

- * 3D curve shape design.
- * Special gear with low noise.



Planetary Mechanism



Frequency Converter Control



Hole of Cooling Fan



Pneumatic Rod

Technical Parameters:

Model	BKBM-V2S
Capacity	2L
Volume of Each Capacity	50~500ml
Pot Quantity	4pcs
Running Time Range	1~9999min
Reciprocal Running Time	1~999min
Adjustable Speed	Revolution 35~335rpm
Revolution	Rotation 70~670rpm
Noise	60 \pm 5dB
Speed Control Mode	Frequency Control
Transmission Mode	Gear Drive
Working Mode	2 or 4 pots can be used each time
Maximum Sample Volume (material + grinding ball)	2/3 of the volume of the ball mill tank
Feed Size	Soft and Crispy material<10mm, Other materials<3mm
Out-put Granularity	Minimum Granularity can be reached to 0.1 μ m
Adjusting Mode of Rotate Speed	Frequency converter with stepless speed regulation
Consumption	0.75KW
Power Supply	AC110/220V \pm 10%, 50/60Hz
External Size(W*D*H)mm	770*470*570
Package Size(W*D*H)mm	820*540*680
Net Weight(kg)	93
Gross Weight(kg)	113
Note: Both pot and ball are optional. For a ball mill with a capacity of 2L, if the matching mill pot specification is 25ml or 50ml, you need to purchase a base holder separately.	

Light Horizontal Planetary Ball Mill



Features:

- * Horizontal structure of grinding pots.
- * Special gear with low noise.



Planetary Mechanism



Frequency Converter Control



Hole of Cooling Fan

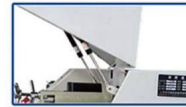

Pneumatic Rod

Technical Parameters:

Model		BKBM-H2L
Capacity		2L
Volume of Each Capacity		50~500ml
Pot Quantity		4 pcs
Running Time Range		1~9999min
Reciprocal Running Time		1~999min
Adjustable Speed	Revolution	35~335rpm
	Rotation	70~670rpm
Noise		60±5dB
Transmission Mode		Gear Drive
Working Mode		2 or 4 pots can be used each time
Maximum Sample Volume (material + grinding ball)		2/3 of the volume of the ball mill tank
Feed Size		Soft and Crispy material<10mm, Other materials<3mm
Out-put Granularity		Minimum Granularity can be reached to 0.1µm
Adjusting Mode of Rotate Speed		Frequency converter with stepless speed regulation
Speed Control Mode		Frequency Control
Consumption		0.75KW
Power Supply		AC110/220V±10%, 50/60Hz
External Size(W*D*H)mm		700*570*520
Package Size(W*D*H)mm		800*610*670
Net Weight(kg)		86
Gross Weight(kg)		150
Note: Both pot and ball are optional. For a ball mill with a capacity of 2L, if the matching mill pot specification is 25ml or 50ml, you need to purchase a base holder separately.		

Optional:

Selection of pot's material: Pot's material has no pollution to the grinding materials and no effect to the appearance of powder.

Technical Parameters:

Category & Request of Grinding Material	Reference for Mill Pots' Material Option
Soil and other Materials which impurities are not allowed to be brought.	Agate Pot
Metal and non-metal materials which impurities are not allowed to be brought.	Zirconia Pot
High hardness materials like diamond, hard alloy.	Hard Alloy Pot
Strong acid and strong alkali substances, and materials under high temperature.	PTFE Mill Pot
Iron and steel minerals, impurities are not highly sensitive materials.	304 Stainless Steel Mill Pot
Pigment material, and materials which can be processed at high temperature.	Nylon Mill Pot
Containing aluminum material like ceramic glaze.	Corundum Pot
Electronic material like lithium battery.	Polyurethane Mill Pot
Easily oxidized materials which need to be protected by special gas.	Vacuum Mill Pot



Nylon Mill Pot



PTFE Mill Pot



Zirconia Pot



Hard Alloy Pot



Polyurethane Mill Pot



Stainless Steel Mill Pot

Matching Ways for Mill Pots and Balls:

	Agate Grinding Ball	Zirconia Grinding Ball	Hard Alloy Ball	Stainless Steel Ball	Alumina Ball	Polyurethane Coated Iron Core Ball	Steel Ball
Agate Mill Pot	▲						
Zirconia Mill Pot		▲					
Hard Alloy Mill Pot			▲				
PTFE Mill Pot	▲						
Stainless Steel Mill Pot				▲			
Nylon Mill Pot		▲					
Corundum Mill Pot					▲		
Polyurethane Mill Pot						▲	

Remarks: ▲ Best Match

Best Match Ratio: Large-sized Ball: 20%; Medium-sized Ball: 50%; Small-sized Ball: 30%.



Stainless steel mill pot can be matched with stainless steel ball



Zirconia mill pot can be matched with zirconia balls



Corundum mill pot can be matched with alumina balls



Hard Alloy mill pot can be matched with zirconia balls



Nylon mill pot can be matched with zirconia balls



PTFE mill pot can be matched with agate balls



Polyurethane mill pot can be matched with Agate balls



Tempered nylon mill pot can be matched with agate balls



Agate mill pot can be matched with agate balls

Grinding Machine Tissue Grinding Machine

Introduction:

BHY1 is an efficient laboratory sample preparation instrument. DNA, RNA and protein from high-throughput samples (soil, animal and plant tissues, microorganisms, etc.) can be extracted and purified, greatly improving grinding efficiency and quality.

Application:

Widely used in biomedicine, animal and plant tissues, food safety, agriculture, environment, forensic medicine, plastics, polymers and so on.

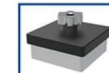

16well 5ml



24well 2ml



32well 2ml

Features:

- * 5 inch touch screen, easy to operate.
- * It can be used as a single machine to observe the running state of the instrument in real time through the display screen.
- * Support any customized grinding jars of various specifications.
- * Independent centrifuge tubes and disposable grinding beads avoid cross-contamination of samples and external contamination.
- * Equipped with door lock sensor, stop immediately after opening the cover.
- * Butterfly button lock, anti-fall.
- * Innovative shock-proof principle, three-dimensional integrated operation mode, innovative grinding bead operation mode.

Technical Parameters:

Model	BHY1
Max. Speed	2500r/min
Grinding Jar	Standard: 24well 2ml Optional: 32well 2ml, 16well 5ml, customized.
Grinding Way	Vertical oscillation, dry grinding, wet grinding
Number Of Grinding Platforms	>2
Grinding Speed	Up to 32 samples (2ml) can be processed in 1 minute.
Grinding Time	0~99min, adjustable
Programming	Multi-stage operation setup is available (loop mode can be set)
Power Supply	Standard: 220V 50/60Hz Optional: 110V 50/60Hz
External Size	265*405*475mm
Package Size	510*375*640mm
Net/Gross Weight	28.5/41kg

Grinding Machine



BK-24S/48S



BK-96S



BK-96LS



BK-96LDS

Application:

It is widely used in biochemistry, microbiology, pharmaceutical chemistry, surface chemistry, physical chemistry, zoology and other fields.
The types of samples processed include plant tissues (such as rice, corn, wheat, beans, peanuts), animal tissues (such as small intestine, heart, lung, fur, etc.), cells, bacteria, yeast, and various medicinal tissues, etc.

Features:

- * The all-metal body improves the stability and safety of the whole machine.
- * The safety lock of the working chamber ensures the safety of samples and laboratory.
- * There is no cross-contamination, and the sample tube is fully enclosed during the crushing process.
- * Good repeatability. The same procedure can be set for the same tissue sample to obtain the same grinding effect.
- * A large number of simultaneous operations can be performed, and the effect is good.

Technical Parameters:

Model	BK-24S	BK-48S	BK-96S	BK-96LS	BK-96LDS
Standard Capacity	24*2ml PE adaptor, 1pc 24*2ml refrigerating adaptor, 1pc	48*2ml PE adaptor, 1pc 48*2ml refrigerating adaptor, 1pc	96*2ml PE adaptor, 1pc 96*2ml refrigerating adaptor, 1pc		
Refrigerating Function	No			Yes, 0 to -50°C	Yes, 20 to -50°C
Display Mode	Touch screen display				5 inches OLED touch screen display
Discharging Granularity	~5µm				
Acceptable Number of Grinding Tubes	>2pcs				
Frequency	0-70Hz				
Time Setting	0-9999s				
Grinding Ball Material and Size	Alloy steel, chromium steel, zirconia, tungsten carbide, quartz sand; 0.1-30mm				
Noise Level	<55dB				
Grinding Method	Wet grinding, dry grinding and low temperature grinding are all available				
Power Supply	220V 50/60Hz(standard), 110V 60Hz(optional)				
Optional Parts	1. Adaptor: Common type: 0.2ml*96; 2.0ml*24; 5.0ml*12; 15ml*8; 25ml*4; 50ml*2; 5.0ml*24; etc. Refrigerating type (can get -196°C): 2.0ml*24; 5.0ml*12; 15ml*8; 25ml*2; 50ml*2; etc. 2. 2-100ml refrigerating grinding tube. They can also be customized.				
Packing Size(mm)	480*350*510	530*400*560	570*490*680	850*590*560	550*550*950
Gross Weight(kg)	25	39	52	74	95

Homogenizer



Application:

Sterile Homogenizer is widely used in homogenization treatment of animal tissues and biological samples. It can be used in food, drug, cosmetics, clinical, molecular, toxin and bacterial detection fields, especially for the preparation of microbial test samples.

Features:

- * 4.3 inch LCD touch screen display and microcomputer control.
- * Intelligent program control, able to set the flapping time, speed, etc.
- * Adjustable flapping spacing, easy to process samples with different amount.
- * Disposable sterile bag guarantees hygiene and safety.
- * Toughened glass window, easy to observe.
- * With anti-pinch function and pause function.

Technical Parameters:

Model	BFH-01	BFH-02
Flapping Time	0.1s~99min59s or continuous operation	
Flapping Speed	3~12 times/s	
Flapping Spacing	0~50mm adjustable	
Effective Capacity	3~400ml	
Program Setting and Storage	10-segment combination programming	
Temp. Control Range	/	RT-60°C
Disinfection Function	UV lamp disinfection, disinfection wavelength 253.7nm	
Sterile Bag	17*30cm, standard 50 pcs	
Anti Pinch Function	With automatic stop anti pinch function	
Start Mode	Soft start	
Consumption	200W	500W
Power Supply	AC110/220V±10%, 50/60Hz	
External Size(W*D*H)	420*230*330mm	
Package Size(W*D*H)	540*310*410mm	
Net Weight	21kg	22kg
Gross Weight	24kg	25kg

Homogenizer



Application:

D-160 can be used in bio-pharmaceuticals, genetic research, tissue destruction, fragmentation, cytoplasmization, pathological analysis, nano-material dispersion, polymerization, ink coatings, fine chemicals, pesticides, prospecting, environmental protection, energy and other fields.

Features:

- * Lightweight design, handheld and can be operated with one hand.
- * The application of different dispersing heads is suitable for liquid samples of 0.1-250ml.
- * High-quality 316L stainless steel dispersing head, corrosion-resistant, high-temperature sterilization.
- * The dispersing head is easy to disassemble and clean; high-speed and high-efficiency motor.
- * The speed is adjustable in 10 gears, and the speed range: 8000-32000rpm.

Components of Dispersing Shaft:

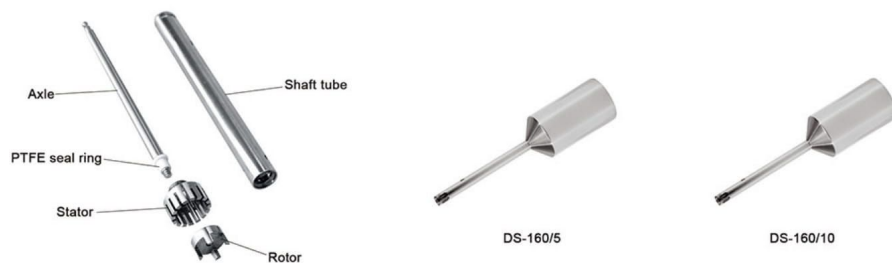

Optional Accessories:

Cat. No.	Combination Stator + Rotor	Model	Working Volume (ml)	Diameter of Stator	Diameter of Rotor	Min. / Max. Immersion Depth	Application
18900113	DS-160/5	D-160	0.1~50	5mm	3mm	7/50mm	Small amounts of solid-liquid mixtures
18900114	DS-160/10		1~250	10mm	6mm	10/120mm	

Technical Parameters:

Model	D-160
Item No.	8014111000
Recommended Configuration	Package 1: D160 drive, H370 Stand, DS-160/5 shaft, volumes from 0.1-50ml Package 2: D160 drive, H370 Stand, DS-160/10 shaft, volumes from 1-250ml
Speed Range	8000-32000rpm
Max. Circum. Speed	6.3-14m/s
Speed Control	10 stage
Working Volume (H ₂ O)	0.1-50ml (Dispersing shaft DS-160/5) 1-250ml (Dispersing shaft DS-160/10)
Max. Viscosity	5000mPa·s
Material of Dispersing Shaft	SS316 & PTFE seal ring
Noise	≤72dB
Ambient Temp.	0-40°C
Relative Humidity	85%RH
Protection Type	IP20
Consumption	160W
Motor Type	AC carbon brush motor
Power Supply	AC110/220V±10%, 50/60Hz(Customizable)
Standard Accessory	Base stand + DS-160/5 dispersing shaft Or Base stand + DS-160/10 dispersing shaft
External Size(W*D*H)	45*55*190 mm
Package Size (W*D*H)	470*240*250mm
Gross Weight	4kg

Homogenizer

Introduction:

Homogenizer can be used in bio-pharmaceuticals, genetic research, tissue destruction, fragmentation, cytoplasmization, pathological analysis, nano-material dispersion, polymerization, ink coatings, fine chemicals, pesticides, prospecting, environmental protection, energy and other fields.

Features:

- * Lightweight design, handheld and can be operated with one hand.
- * The application of different dispersing heads is suitable for liquid samples of 0.2~30000ml.
- * High-quality 316L stainless steel dispersing head, corrosion-resistant, high-temperature sterilization.
- * The dispersing head is easy to disassemble and clean; high-speed and high-efficiency motor.



Technical Parameters:

Model	BH-50P
Speed Range	10000~34000rpm
Processing Volume	0.2~30000ml
Standard Accessories	Work stand, standard work head (30G)
Consumption	1050W
Power Supply	AC110/220V±10%, 50/60Hz
External Size(W*D*H)	320*210*680 mm
Package Size (W*D*H)	650*360*180mm
Net/Gross Weight	9.5kg/10kg

Optional Working Head:

Model	Processing Volume	Applicable Viscosity
6G	0.2~10ml	<100CP
8G	10~60ml	<100CP
10G	30~150ml	<1000CP
18G	50~1500ml	<5000CP
18F	50~1500ml	<5000CP
25G	100~5000ml	<8000CP
25F	100~5000ml	<8000CP
30G	200~25000ml	<10000CP
30F	200~20000ml	<10000CP
30J-Q	1000~30000ml	<10000CP
30J-X	1000~30000ml	<10000CP

Handheld High-Speed Homogenizer

Introduction:

BK-H6B type is suitable for mixing, emulsification and homogenization of liquid and liquid; dispersion of liquid and solid powder; It can be used in pharmaceutical, biochemical, food, nanomaterials, coatings, adhesives, daily chemicals, printing and dyeing, petrochemicals, papermaking chemistry, polyurethane, inorganic salts, asphalt, silicone, pesticides, water treatment, heavy oil emulsification, Diesel emulsification, electronics, batteries and other industries are also ideal products for factories, scientific research institutions, colleges and universities, medical units, etc. for scientific research, product development, quality control and application in the production process.



Feature:

- * One-handed control, user-friendly operation, super power, better experimental effect.
- * Double insulation protection to ensure safety.
- * All parts of the working head contacting the material are made of high-quality stainless steel, with good corrosion resistance.
- * The working head is connected with the drive motor by a coupling, which is easy and flexible to disassemble.
- * Stepless speed controller, convenient speed regulation and stable operation.

Technical Parameters:

Model	BK-H6B
Speed Range	1000-32000r/min
Working Volume	0.2-150ml (H ₂ O)
Standard Dispersing Shaft	10G
Max. Viscosity	2000mpas
Consumption	120W
Speed Control	6 stage
Speed Controller	Stepless speed controller
Material Of Dispersing Shaft	SS316L & PTFE
Process Type	Micro batch processing
Power Supply	220V 50/60HZ
Relative Humidity	80%
Optional Stand	Single column stand
Net Weight	0.6kg
Package Size(W*D*H)	470*335*200mm
Gross Weight	6kg

Dispersing Shaft:

Type	Working Volume (ml)	Viscosity (cp)	Speed (m/s)	Length (m/s)	Diameter (m/m)
6G	0.2-50	100	5	125	6
8G	10-60	500	8	150	8
10G	30-150	2000	10	185	10
6G-ST	0.2-50	100	5	125	6
8G-ST	10-60	500	8	150	8
10G-ST	30-150	2000	10	185	10

Muffle Furnace



Features:

- * External material: cold-rolled steel with anti-bacterial powder coating and internal material: imported high density ceramic fiber. All stainless steel glory hole, make sure the color not change.
- * Dual ceramic inner chamber and hollow heat insulation ensure that the temperature can go up quickly. Heating rate is about 60°C/min.
- * Automatic parallel pressure door technology ensures the inner chamber temperature evenness and without leakage under the high temperature.
- * PID micro digital screen controller, fixing temperature, over-temperature alarming and auto-stop.
- * Safety protection measures: thermocouple failure, cut off power automatically when open the door and over temperature protection to avoid accidents occurring.
- * Double-shell hollow thermal insulation, the shell not hot and the furnace internal cool quickly.

Technical Parameters:

Model	MC2.5-12	MC5-12	MC10-12
Max Temp.	1200°C		
Temp. Rising Time (Empty/min)	≤30		
Temp. Accuracy	±1°C		
Capacity(L)	2	7	16
Consumption(KW)	1.5	3	6
Power Supply	110/220V±10%,50/60HZ		
Internal Size(W*D*H)mm	200*120*80	300*200*120	400*250*160
External Size(W*D*H)mm	450*685*600	530*785*640	600*895*700
Package Size(W*D*H)mm	580*775*730	660*875*770	730*985*830
Gross Weight(kg)	45	60	98

Features:

- * Program controlling temperature for TP series.
- * Heating wire is set in four sides of the furnace, anti-corrosion, prevent contamination.
- * Special insulation design, low shell temperature.
- * SCR control, PID parameter self-setting;
- * Low energy consumption.
- * Multiple safety protection design:
 - Over-temperature alarm;
 - Power off when over-temperature/over-load.
 - Manual or automatic switch without interference;
 - Built-in parameter password control function.



MX6-10T/TP; MX8-10T/TP; MX16-10T/TP; MX8-12T/TP; MX6-12T/TP; MX8-12T/TP; MX8-13T/TP; MX10-13T/TP; MX30-10T/TP; MX30-12T/TP
MX6-16TP; MX11-16TP; MX6-17TP; MX11-17TP

Technical Parameters:

Model	MX6-10T/TP	MX8-10T/TP	MX16-10T/TP	MX30-10T/TP	MX6-12T/TP	MX8-12T/TP	MX30-12T/TP
Max. Temp.(°C)	1000			1200			
Capacity(L)	6	8	16	30	6	8	30
Temp. Accuracy	±1°C						
Consumption(KW)	2.8	4	6	10	2.8	4	10
Power Supply	220/380V±10%, 50/60HZ ;(110V only suitable for MX6-10T/TP)						
Heating Rate	0-30°C/min						
Rising Time(Empty)	30 minutes						
Temp. Uniformity	±5°C						
Material	External material: Cold rolled steel carbon steel spraying Internal material: Ceramic inner chamber						
Heating Element	Nickel chromium alloy wire						
Temp. Control	Intelligent temperature controller						
Optional Accessory Functions	Temperature measuring hole; Exhaust chimney; Furnace bottom plate Automatically power off once the door is opened; 30 programmable periods(only for T Type)						
Internal Size(W*D*H)mm	180*230*150	200*300*120	250*400*160	300*500*200	180*230*150	200*300*120	300*500*200
External Size(W*D*H)mm	500*510*540	500*580*660	550*690*700	770*820*580	480*500*660	500*580*660	770*820*580
Package Size(W*D*H)mm	630*700*870	630*800*870	680*910*870	870*1110*990	630*700*870	630*800*870	870*1110*990
Gross Weight(kg)	82	84	111	146	82	84	146

Model	MX8-13T/TP	MX10-13T/TP	MX6-16TP	MX11-16TP	MX6-17TP	MX11-17TP
Max. Temp.(°C)	1300		1600		1700	
Capacity(L)	8	10	6	11	6	11
Temp. Accuracy	±1°C					
Consumption(KW)	4		6	8	5	8
Power Supply	220/380V±10%, 50/60HZ					
Heating Rate	0-30°C/min					
Rising Time(Empty)	30 minutes					
Temp. Uniformity	±5°C					
Material	External material: Cold rolled steel carbon steel spraying Internal material: Ceramic inner chamber					
Heating Element	Nickel chromium alloy wire					
Temp. Control	Intelligent temperature controller					
Optional Accessory Functions	Temperature measuring hole; Exhaust chimney; Furnace bottom plate Automatically power off once the door is opened; 30 programmable periods(only for T Type)					
Internal Size(W*D*H)mm	200*300*120	200*300*180	150*300*120	200*300*180	150*300*120	200*300*180
External Size(W*D*H)mm	630*650*730	600*640*850	650*750*1000	700*750*1200	650*750*1000	700*750*1200
Package Size(W*D*H)mm	710*910*920	770*860*1050	920*800*1150	1100*1050*1350	800*920*1150	1100*1050*1350
Gross Weight(kg)	119	130	237	280	237	280

Filtration Apparatus

Manifolds Vacuum Filtration



Product Introduction:

- * It is convenient to filtrate several samples at the same time.
- * 316L stainless steel holder, corrosion resistance, acid and alkali resistance.
- * Each holder has individual control valve, so one vacuum pump can support operations of single and multi-branch manifold filter.
- * It can be widely used in chemistry analysis, pharmaceutical, sanitation test, water quality analysis, science research fields and so on.

Standard Accessory:

- * Lid
- * Stainless steel valve
- * Clamp of aluminum alloy
- * 316L stainless steel holder
- * Glass funnel (300ml) / 316L stainless steel funnel (300ml)
- * Borosilicate glass filter head / 316L stainless steel filter head

Technical Parameters:

Model	Type	Funnel	Support Screen&Pore Size	Connection	Holder	Package Size(W*D*H)	G.W.
MVF-1G	1-branch	Glass	PTFE, 20µm	Ground Joint	SS316	270*230*130mm	3kg
MVF-1S		SS316	SS316,100µm	Integral, SS316	SS316	270*230*130mm	2.9kg
MVF-3G	3-branch	Glass	PTFE, 20µm	Ground Joint	SS316	535*360*380mm	9kg
MVF-3S		SS316	SS316,100µm	Integral, SS316	SS316	480*260*130mm	5.7kg
MVF-6G	6-branch	Glass	PTFE, 20µm	Ground Joint	SS316	965*365*390mm	17kg
MVF-6S		SS316	SS316,100µm	Integral, SS316	SS316	900*260*130mm	10.3kg

Solvent Filtration Apparatus

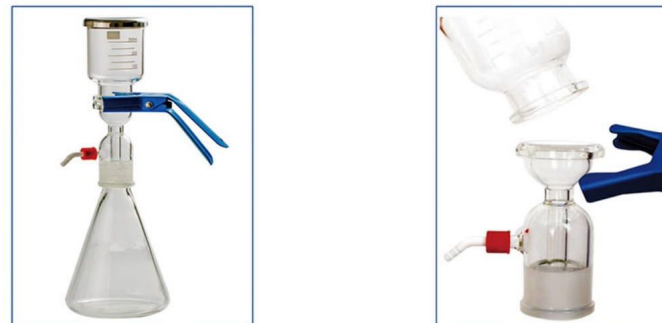

Applications:

Solvent filter is a regular device of chemistry lab, it is indispensable equipment for HPLC analysis. This device can also be used in instrumental analysis, sanitary inspection, pharmaceutical industry, pesticide liquid filtration, petroleum, environmental monitoring fields. It can monitor and remove the particles and bacteria in the liquid.

Features:

- * It is made of high quality toughened glass.
- * With good press-resistance and leakproofness, it could be used for sterilizing at high temperature of 121°C.
- * The PTFE type is acid and alkali resistant, corrosion resistant, can filter all kinds of aqueous solution, organic solution and corrosive liquid.

Standard Accessory:

Solvent Filter system consists of solvent filter

Filter Include:

- * Triangle fluid bottle
- * Core filter head
- * Filter bowl
- * Clamp
- * Dust cover
- * Rubber hose
- * Hose linker

Technical Parameters:

Model	Funnel	Pore Size of Filter	Support Screen	Receiving Bottle	Membrane	Packing Size	Gross Weight
SFA-50.1L	300ml	10µm	Pyrex glass	1000ml	Φ47 or Φ50mm	310*310*190mm	2kg
SFA-50.2L	500ml	10µm	Pyrex glass	2000ml	Φ60mm	370*345*255mm	3.1kg
SFA-50.PT	300ml	20µm	PTFE	1000ml	Φ47 or Φ50mm	310*310*190mm	2kg

Digester Microwave Digester



Introduction:

BIOBASE microwave digestion system provides a fast, safe and automatic solution for samples, accelerates the speed of sample digestion reaction under high pressure conditions.

It is widely used in food, textile, plastic, geological, metallurgical, coal, biological medicine, petroleum chemical industry, environmental monitoring, sewage treatment, battery manufacturing, cosmetics, etc.

Features:

- * Microwave non-pulse continuous automatic frequency conversion control, 0 ~ 100% automatic output.
- * Vertical bidirectional waveguide design, 3D output technology, and matching harmonic power frequency achieve a high degree of field uniformity.
- * SUS316 stainless steel chamber.
- * Self-locking buffer explosion-proof furnace door, when the reaction is abnormal, buffer structure to ensure the operator's personal safety and integrity of the door structure.
- * 8"TFT-LED touch screen display the temperature and pressure curve in real time.
- * 360° continuous rotation in the same direction, microwave uniformity, to ensure that the microwave environment of each sample is the same, improve the consistency of experimental results.
- * Non-contact infrared temperature control system and non-contact pressure control system.
- * Exhaust and cooling system: acid-resistant centrifugal fan, exhaust air volume is not less than 5m³/min; With air cooling function, continuous cooling for the reaction vessel, temperature and pressure real-time display.
- * With fault self-test system, when the temperature or pressure control system fails, the instrument will automatically cut off the microwave emission, and alarm.
- * The material is TFM for the inner vessel and PEEK aerospace composite material for the vessel explosion-proof outer casing.

Technical Parameters:

Model	BMD-10H	BMD-12H	BMD-Z40
Chamber	58L, SS316	58L, SS316	72L, SS316
Microwave Source	Professional microwave source, industrial microwave power supply		
Microwave Frequency	2450 MHz		
Microwave Output Power	1400~2800W		
Display	8"TFT-LED touch screen		
Max. Temp.	300°C		
Temp. Accuracy	±0.5°C		
Max. Pressure	10MPa		15MPa
Pressure Accuracy	±0.01Mpa		
Temperature Sensor	Non-contact infrared temperature sensor		
Vessel Quantity Capacity	10 Vessels	12 Vessels	40 Vessels
Vessel Volume	70ml(Standard), 100ml(Optional)		
Vessel Material	Vessel made of TFM, explosion-proof outer vessel made of PEEK aerospace composite material		
Cooling Method	Forced air cooling		
Standard	Turntable bracket, PEEK explosion-proof outer*10, TFM inner vessel*10, infrared temperature sensor, graphite acid evaporator	Turntable bracket, PEEK explosion-proof outer*12, TFM inner vessel*12, infrared temperature sensor, graphite acid evaporator	Turntable bracket, PEEK explosion-proof outer*40 TFM inner vessel*40, infrared temperature sensor*2, graphite acid evaporator*2, transfer inner vessel bracket*2, spanner
Consumption	2600W		2800W
Power Supply	AC220±10%, 50/60Hz (Standard); AC110V.60Hz (Optional)		
External Size (W*D*H)	590*620*830mm		720*720*800mm
Package Size (W*D*H)	Main Body: 590*620*830mm Accessory: 820*300*130mm		Main Body: 800*800*950mm Accessory: 200*250*250mm; 200*250*250mm
Gross Weight	Main Body: 75kg Accessory: 25kg	Main Body: 75kg Accessory: 27kg	Main Body: 100kg Accessory: 20kg; 20kg

Microwave Synthesis Extractor

Features:

- * The power is automatically adjustable in 10 gears, and the microwave power automatically changes with temperature.
- * 42L Stainless steel chamber with multiple layers of anti-corrosion coating.
- * High precision temperature sensor, real-time monitoring of reaction temperature, accurate control of reaction process.
- * 8-inch touch screen, real-time display of closed reaction tank temperature and temperature curve.
- * Saving and querying experimental records.
- * Open reaction system, dropping funnel and condenser can be installed for reflux reaction.
- * Equipped with inert gas protection interface.



Technical Parameters:

Model	BK-ME1
Reaction Volume	10~1500ml
Stirring Speed	Magnetic: CVT 0~2000rpm (Standard); Mechanical: 0~2000rpm (Optional)
Continuous Working Time	8 hours
Temp Control Range	0~300°C
Temp Control Accuracy	±1°C
Temp Measurement Accuracy	±0.2°C
Consumption	0~1000W, 10 gears automatically adjustable
Power Supply	AC110/220V, 50/60Hz
External Size	400*600*450mm
Package Size	500*700*500mm
Net/Gross Weight(kg)	40/55kg

Microwave Catalytic Synthesis Extractor



Features:

- * High precision temperature sensor.
- * Rate heating, programmable temperature control, 20 reaction stages can be set.
- * 30L stainless steel chamber, non-magnetic.
- * The operation is simple and the whole experiment process is monitored.
- * LCD display real-time reaction parameters and temperature curves.
- * Can store 10 groups of reaction conditions.
- * Embedded printer, one-click printing of experimental parameters.
- * Open reaction system, dropping funnel and condenser can be installed for reflux reaction.
- * Can be equipped with inert gas joint, can support atmosphere protection.

Technical Parameters:

Model	BK-ME2
Reaction Volume	10~1000ml
Stirring Speed	Magnetic: 0~2000rpm; Optional mechanical stirring kit.
Continuous Working Time	≥15 hours
Temp Control Range	0~300°C
Temp Control Accuracy	±1°C
Temp Test Accuracy	±0.2°C
Consumption	0~1000W, automatic continuous stepless adjustable
Power Supply	Standard: 220V 50Hz; Optional: 110V 60Hz
External Size	520*760*670mm
Net Weight(kg)	35kg
Gross Weight(kg)	40~45kg

Solid Phase Extraction System



Introduction:

The solid phase extraction system is a negative pressure solid phase extraction device. It uses a solid adsorbent to adsorb the target compound in a liquid sample, separates it from the sample matrix and interfering compounds, and then eluates it with an eluent or heats to desorb it to achieve separation and Purpose of enrichment of target compounds (I.e. the separation, purification and enrichment of the sample), the solid phase extraction instrument aims to reduce the interference of the sample matrix and improve the detection sensitivity.

Features:

- * The whole machine of 12, 24, and 36-well square solid phase extraction instrument is made of transparent organic glass, which has strong corrosion resistance;
- * The wall thickness of the vacuum tank is uniform, so it can withstand high negative pressure above -0.096Mpa, and it will not deform after long-term high-pressure use;
- * The pressure is uniform everywhere, the air tightness is good, and the stability is strong;
- * The extraction speed is consistent, and the control and adjustment are convenient;
- * Multi-channel can be controlled independently, and the joint is corrosion-resistant;
- * The internal test tube rack of the solid phase extraction instrument is made of polytetrafluoroethylene, so it has high corrosion resistance.

Technical Parameters:

Model	BK-SPE-12	BK-SPE-24	BK-SPE-36
Capacity	12	24	36
Gas Control Mode	Independent control		
Working Zone Size (mm)	210*100*138	210*120*138	210*140*138
Pressure Display	Pressure gauge		
Vacuum Value	0.098Mpa		
Flow Control Valve	12	24	36
Package Size (mm)	460*200*290mm		
Gross Weight (kg)	3.6	3.8	4

Separatory Funnel Shaker



Features:

- * Vertical shaker equipment can automatically shake separating funnel, complete liquid-liquid extraction, sample mixing, etc.
- * Large amplitude, high speed, working time can be set.
- * Adjustable frequency, batch samples processing, high efficiency, high recovery rate, minimizing operator exposure to chemical agents to protect personal safety.
- * Easy to install & operate, meet the needs of all types of laboratory extraction purification.
- * Shaking by both vertical & slant methods. Powerful strength for the mix of extraction liquid & water.
- * Low noise & long-time stable working.
- * Rotated sample holder, easy to install & detach specimen.
- * Varies sample holders alternative to adapt varies experiments.

Technical Parameters:

Model	BK-VS06	BK-VS08	BK-VS10
Sample Capacity	6pcs	8pcs	10pcs
Shaking Method	Vertical Shake (tilt angle 0-20° adjustable)		
Shaking Amplitude	≥40mm		
Shaking Frequency	50-300 times/min adjustable		
Frequency Control	Infinitely variable speeds		
Operation Mode	Continuous operation, interval operation, curve operation		
Timing Range	0-99 hours, can count down		
Applied Vessel	250ml-2000ml separating funnel, 100ml and 250ml conical flask, 100ml measuring cylinder with stopper, 100ml colorimetric tube with stopper, 100ml volumetric flask with stopper, etc., no need to change the fixture		
Extraction Efficiency	95-110%		
Rated Load	Bilateral symmetry 11kg		
Power Supply	220V 50Hz		
Packing Size	900*800*1050mm		
Gross Weight	150kg		

Graphite Digester



Introduction:

Graphite digestion instrument is widely used in food, biological samples, sewage treatment, soil environmental protection, agricultural products, cosmetics, chemical, biochemical and other industries as well as universities, scientific research departments of soil, feed, plants, seeds, ore, biological tissue and other samples digestion treatment, selection of novel and unique, acid and alkali resistance, high temperature resistance.

Features:

- * The material adopts isostatic high purity graphite, the surface is treated by Teflon, acid and alkali resistance, high temperature resistance.
- * Powder coated steel shell, durable.
- * Simple operation, large sample processing batch.
- * LCD display, real-time temperature value display, countdown display timer can accurately control the heating time.
- * PID temperature control technology, high temperature control precision, fast heating speed.
- * Automatic fault detection and alarm function.
- * Built-in temperature deviation calibration function.

Technical Parameters:

Model	BJPX-SM12
Temp Range	RT.+5°C~260°C
Temp Accuracy	±1.0°C
Display Accuracy	0.1°C
Timing Range	1~9999min(h) or continue
Power Supply	AC110V/220V±10%, 50/60Hz
Digestion Module	Standard: SM004 Optional: Other modules
External Size	420*290*175mm
Package Size	450*320*220mm
Net Weight	8.5kg
Gross Weight	9.5kg

Digestion Module:

Model	Diameter of Digestion Hole	Suitable Digestion Tube Capacity	Max Num. of Digestion Tube
SM001	Φ18mm	5ml, 10ml	35
SM002	Φ21mm	5ml, 10ml	24
SM003	Φ25mm	15ml, 20ml, 25ml	20
SM004	Φ31mm	50ml, 60ml	12
SM005	Φ42mm	100ml	8
SM006	Customizable		

Heavy Metal Digester



GDA-30

Introduction:

GDA-30 has the advantages of fast digestion, high efficiency, convenience and large processing capacity. It is an ideal pre-treatment equipment for atomic absorption spectroscopy, ICP mass spectrometry and other elemental analysis instruments.

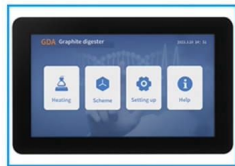

Touch screen operation



PTFE Digestive Tube

Application:

According to the experimental needs, can choose PTFE and silica glass two kinds of test tube, fully expand the user digestion acid range. Suitable for food, medicine, agriculture, forestry, environmental protection, chemical, biochemical and other industries as well as universities, scientific research departments to soil, feed, heavy metals, ore and other samples digestion treatment before chemical analysis.



Soil



Ore

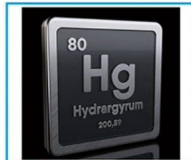

Heavy Metal



Feed

Features:

- * The temperature in the furnace can be continuously adjusted, high precision , the temp. of the controlled point is constant, high heat conduction efficiency.
- * Separate isolation design of control system and heating system to reduce the influence of high temperature radiation and acid corrosion on the control system.
- * With overvoltage, overcurrent, overheat, overtemperature alarm, automatic fault alarm and other multiple protection.
- * Embedded software temperature control technology, PID temperature control.
- * Automatic detection of heating unit work fault and can determine the fault module.
- * New flame retardant environmental protection materials and air duct insulation.
- * PTFE and borosilicate glass two kinds of test tubes are available.
- * Surround three-dimensional heating, so that all parts of the sample are heated evenly.
- * Graphite block is treated with special anti-oxidation technology to prolong the service life.

Technical Parameters:

Model	GDA-30
Temp. Range	RT+5°C~450°C
Temp. Accuracy	±1°C
Capacity	30pcs
Digestive Tube	Glass tube scale 50mL(full capacity 100mL) PTFE tube (full capacity 70mL) (standard 30pcs)
Heating Mode	Infrared heating and high purity graphite conduction
Insulation Mode	Ceramic fiber, split air duct insulation
Display	7-inch high resolution color LCD screen
Alarm	Over temperature alarm
Consumption	3.4KW
Power Supply	Standard: 220V±10%, 50/60Hz Optional: 110V±10%, 50/60Hz
External Size	480*390*177mm
Package Size	610*500*455mm
Net Weight	26kg
Gross Weight	38kg

Kjeldahl Apparatus Graphite Digester



GDA-10



GDA-20

Introduction:

Graphite Digester adopts infrared radiation graphite conduction heating technology, accurate temperature control, uniform heating, fast heating speed.



Touch screen operation



Collection System



Reflux design

Application:

Food, medicine, agriculture, forestry, environmental protection, chemical, biochemical and other industries as well as quality inspection institutions, universities, scientific research departments to soil. Sample digestion processing prior to chemical analysis of grain, feed, food, water, plants, seeds, ores, heavy metals, etc



Food

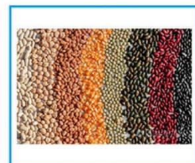

Grain



Feed



Soil

Features:

- * Infrared radiation graphite conduction heating method, fast heating speed, the temperature difference between the holes is small, and the sample digestion is consistent.
- * PID intelligent temperature control algorithm, accurate and stable control, adapt to different sample pretreatment.
- * Two heating methods of curve heating and linear heating, 200 groups of digestion programs can be edited and stored, and each group can be set up to 25 segments.
- * Temperature and time gradient to meet different experimental needs of users.
- * Special anti-corrosion treatment to avoid the corrosion of acidic liquid on the machine.
- * 7-inch high resolution LCD display, real-time display temperature curve.
- * Overvoltage, overcurrent, overheating and other alarm Settings and leakage protection.
- * New ceramic fiber insulation layer and air duct insulation technology.
- * Standard digestive tube cooling rack and drip tray, the digestive tube can be cooled quickly.
- * Exhaust hood, PTFE sealing cap seal, prevent operators from inhaling harmful gases.

Technical Parameters:

Model	GDA-10	GDA-20
Temp. Range	RT+5°C~450°C	
Temp. Accuracy	±1°C	
Capacity	10pcs	20pcs
Digestive Tube	Glass tube 300ml*10	Glass tube 300ml*20
Heating Mode	Infrared heating and high purity graphite conduction	
Insulation Mode	Ceramic fiber, split air duct insulation	
Display	7-inch high resolution color LCD screen	
Consumption	1.8KW	3.4KW
Power Supply	Standard: 220V±10%, 50/60Hz Optional: 110V±10%, 50/60Hz	
External Size	360*390*177mm	480*390*177mm
Package Size	620*500*560mm	700*610*770mm
Net Weight	20kg	26kg
Gross Weight	36kg	58kg

Semi Automatic Kjeldahl Nitrogen Analyzer

Applications:

Widely used in food processing, feed production, tobacco, animal husbandry, soil fertilizer, environmental monitoring, medicine, agriculture, scientific research, teaching, quality supervision and other fields, nitrogen or protein content determination; It can also be used for the detection of ammonium salt, volatile fatty acid/alkali, soil cation exchange capacity, etc.

Features:

- * 7-inch high-resolution color LCD display, real-time control of the experimental process
- * Manual/automatic dual mode can be switched freely. In the automatic mode, it can automatically quantitatively add lye, boric acid receiving solution, dilution water and other automatic waste discharge systems. After the experiment is completed, the waste liquid in the digestive tube is automatically discharged, and the rinsing time can be set freely.
- * The distillation time can be set arbitrarily, and the alarm prompts the end of the distillation. The safety protection design of the experiment, the safety door protection and the reminder function that the digestive tube is not in place
- * Water-saving function design, condensed water flow rate 1.5L/min, real-time flow monitoring, low water pressure alarm display
- * Real-time monitoring of steam generator temperature, pressure and water level to ensure safe and reliable experiment process
- * Emergency stop operation function and automatic fault detection function, sound and light alarm in case of fault, intelligent bullet box display
- * Adopt high reliable PTFE pump, special corrosion resistance, anti crystallization, stable liquid addition, stable negative pressure suction
- * The whole machine of the instrument is made of ABS engineering plastics, which is corrosion-resistant, waterproof and leak-proof

Technical Parameters:

Model	AKN-01	AKN-01S
Measuring Range	0.1mg-240mg N	
Recovery Rate	≥99.5%	
Sample Amount	Solids≤6g; Liquids≤20mL	
Distillation Speed	3-6min/sample	
Distillation Time	0-60min	
Repeatability	≤0.5%	
Cooling Water Consumption	1.5L/min	
Operating Mode	Automatic/manual dual modes	
Automatic drainage	/	Automatically emptying and cleaning digestive tube waste liquid
Reagents Bottle Liquid Level Detection	/	Yes
Reagents Bottle	4pcs	
Protection Device	Flow rate detection, liquid level alarm, over temperature and over pressure protection	
Display	7 inches LCD display	
Rated Power	1.4kW	
Power Supply	Standard: 220V 50/60Hz, optional: 110V 50/60Hz	
External Size	490*380*725mm	
Net Weight	35kg	
Packing Size	630*560*1350mm	
Gross Weight	52kg	



Fully-automatic Kjeldahl Nitrogen Analyzer

Applications:

Widely used in food processing, feed production, tobacco, animal husbandry, soil fertilizer, environmental monitoring, medicine, agriculture, scientific research, teaching, quality supervision and other fields, nitrogen or protein content determination; It can also be used for the detection of ammonium salt, volatile fatty acid/alkali, soil cation exchange capacity, etc.

Features:

- * Automatically add dilution water, add alkali, add receiver solution, distillation, titration, calculation, printing, automatic emptying function of digestion tube and receiving cup, steam flow adjustment, fault self-checking and other functions.
- * New Android operating system, with 7-inch high-definition color touch screen, real-time control of the experiment process.
- * External titration cup design, the operator can control the experimental process in real time.
- * Steam flow can be adjusted within the range of 0~100%.
- * With user authority classification function, operation log query, data traceability management can be realized.
- * The instrument has a built-in 8G storage space and a variety of built-in application solutions.
- * Quick emptying function of digestive tube, avoiding experimenters from contacting distillation high-temperature waste liquid.
- * High-precision dosing pump and titration system ensure the accuracy of experimental results.
- * Titration process image curve display, online monitoring of the whole experimental process, real-time monitoring.

Technical Parameters:

Model	AKN-10S
Measuring Range	0.1mg-240mg N
Recovery Rate	≥99.5%
Sample Amount	Solids≤6g; Liquids≤25mL
Distillation Speed	3-8min/sample
Distillation Time	0-99min
Repeatability	≤0.5%
Titration Precision	1.0ul/step
Storage Data	1 million groups
Reagents Bottle Liquid Level Detection	Yes
Protection Device	Flow rate detection, liquid level alarm, over temperature and over pressure protection
Display	7 inches LCD display
Rated Power	12kW
Power Supply	Standard: 220V 50/60Hz, optional: 110V 50/60Hz
External Size	490*380*725mm
Net Weight	38kg
Packing Size	630*560*1350mm
Gross Weight	52kg



Semi-Automatic Kjeldahl Nitrogen Analyzer (Kjeldahl Distiller)



Features:

- * 4-inch color touch screen, man-machine dialogue is easy to operate and easy to learn.
- * Complete the whole experimental process with one key (adding boric acid, adding diluents, adding alkali, automatic distillation, sample recovery, automatic stop sample separation and recovery).
- * 304 stainless steel steam pot has stable performance, reliable and strong pressure resistance.
- * High polymer material ammonia separator can meet the application of alkaline conditions.
- * The system automatically shuts down after 60 minutes of unmanned operation, energy saving, safety and rest assured.
- * Safety door to ensure the safety of operators.
- * Steam system water shortage alarm prompts, shutdown to prevent accidents.
- * Steam pot over temperature alarm, stop to prevent accidents.

Technical Parameters:

Model	BKN-200
Measure Range	0.1mg~240mg N
Reproducibility	±0.5%
Recovery Ratio	99~101% (±1%)
Analysis Time	3~5min/sample (Cooling water temperature is 18°C)
Distillation Time	0~9990s, adjustable
Sample Amount	Solid ≤6g; Liquid ≤16ml
Display	4-inch color touch screen
Automatic Shutdown Time	60 minutes
Water Consumption	1.2~3L/min
Consumption	2000W
Power Supply	AC220 V ±10%, 50/60Hz
Standard Accessories	Reagent buckets*3, Waste bucket*1, Reagent pipelines*4; Cooling water pipes*2
External size(W*D*H)	360*550*700mm
Gross Weight	23Kg
Packing size(W*D*H)	Main body: 670*580*870mm Accessories: 600*400*470mm
Gross Weight	Main body: 26kg Accessories: 6kg



BKN-983

Features:

- * 7 inch LCD display.
- * Manual/automatic mode can be switched freely.
- * The control system has high precision and good stability.
- * 99 groups of user-defined programs.
- * Automatic control of adding alkali and boric acid solution, silution and elution.
- * Multi-protection function, such as safety door, overpressureprotection, watershortageprotection, etc.

Technical Parameters:

Model	BKN-983
Measure Range	0.1~240mgN
Recovery Ratio	≥99.5%
Reproducibility	±0.5%
Data Storage	100,000 groups
Sample Amount	Solid<6g; Liquid<16ml
Distillation Speed	3~4min/sample
DistillationTime	0~999s
Cooling Water Consumption	15L/min
Requirement of Cooling Water	<18°C
Consumption	2000W
Power Supply	AC220V,50/60Hz
Interface	RS 232
Standard Accessories	10L reagent barrel*3, 20L waste liquid bucket*1
PackingSize(W*D*H)	1000*600*960mm
GrossWeight	54kg

Fully Automatic Kjeldahl Nitrogen Analyzer

Features:

- * Large LCD touch screen.
- * The control system has high precision and good stability.
- * Choose R, G, B three-color light source and three-color sensor, with a wide range of color adaptation and high precision.
- * 99 groups of user-defined programs.
- * 304 stainless steel material.
- * Multi-protection function, such as safety door, overpressure protection, water shortage protection, etc.

Additional Features of BKN-987A:

- * It could show the titration curve.
- * One key to wash the alkali liquor pipes.
- * Automatically discharge the waste in the digestive tubes.



BKN-987/987A

Technical Parameters:

Model	BKN-987	BKN-987A
Working Process	Adding quantitative sample dilution, alkali liquor and absorption liquid; Automatically finishing distillation, titration, print and liquid-discharging.	
Measurement Range	0.1~240mgN	0.1~210mgN
Sample Amount	Solid<6g; liquid<16ml	
Measurement Time	4-6min/(cooling water temperature 18°C)	
Requirement of Cooling Water	<18°C	
Cooling Water Consumption	1.5L/min	
Titration Solution Concentration	0.01~5 mol/L	
Titration System	High-precision plunger type titration system	
Repeatability	±0.5%	
Recovery Ratio	≥99.5%	
Data Storage	100,000 groups	
Consumption	2000W	
Power Supply	AC220V, 50/60Hz	
Interface	RS 232	
Standard Accessories	Printer, 10L reagent barrel*3, 20L waste liquid bucket*1, 1L reagent bottle*1	Printer, 10L reagent barrel*3, 20L waste liquid bucket*1, 1L reagent bottle*1, Refrigeration cycle system*1, 250g catalyst sheet*1 bottle
Packing Size(W*D*H)	1000*600*960mm	Main body: 1000*600*960mm; Accessories: 710*430*600mm
Gross Weight	57kg	Main body: 59kg; Accessories:38kg

Kjeldahl Digestion Furnace



Features:

- * This product adopts PID intelligent temperature control technology, which has good temperature uniformity and strong sample digestion consistency.
- * Adopting aviation industry coating technology, beautiful and durable.
- * LED display, with timing shutdown, alarm and other functions.
- * Stainless steel material has certain anti-corrosion ability.

Technical Parameters:

Model	BKD-8B
Temp. Range	RT~400°C
Temp. Precision	±1°C
Heating Pipe	Aluminium alloy pipe(Nichrome wire)
Heating Speed	8~15°C/min
Heating Holes	8
Aperture	Φ43.5mm
Digestion Tube Size	300ml±0.25ml
Consumption	2.2KW
Power Supply	AC220V, 50/60Hz
Package Size(W*D*H)	610*610*630mm
Gross Weight	29kg

Digester

Introduction:

Digester is a sample digestion and transformation equipment according to the classical wet digestion principle. It is mainly used in agriculture, forestry, environmental protection, geology and petroleum, chemical industry, food and other departments as well as universities and scientific research departments for the digestion of plants, seeds, feed, soil, ore and other samples before chemical analysis. It is the best supporting product of Kjeldahl nitrogen analyzer.



Features:

- * The high density graphite heating module has good uniformity and small temperature buffer, and the design temperature is up to 550°C.
- * Aluminum alloy heating module surface using aviation industry coating technology, beautiful, durable, design temperature 450°C.
- * The temperature control system adopts 5.6 inch color touch screen, Chinese and English conversion, easy to operate.
- * Formula program input using table type fast input method, clear logic, fast speed, not easy to make mistakes.
- * 0-40 segment program can be arbitrarily selected and set.
- * Single point heating and curve heating modes are optional
- * Intelligent PID self-tuning temperature control of high precision, reliable and stable.
- * Electrical control system adopts solid state relay, quiet, anti-interference ability is strong.
- * Segmented power supply and power outage prevention restart function can avoid potential risks.
- * Equipped with overtemperature and overpressure, over-current protection module.

Technical Parameters:

Model	BKD-10RS BKD-10RL	BKD-15RS BKD-15RL	BKD-20RS BKD-20RL
Temp.Range	S=RT+5°C-550°C,L=RT+5°C-450°C		
Temperature Accuracy	±1°C		
Capacity	10pcs	15pcs	20pcs
Digestive Tube	Glass tube 300ml*10	Glass tube 300ml*15	Glass tube 300ml*20
Aperture Diameter(mm)	Φ43.5		
Heating Block Material	S=High density graphite / L=6061 Aluminum alloy		
Rate of Heating	≈ 8--15°C /min		
Temperature Control System	1-40 segment program heating/single point heating dual mode		
Formula Management	9 groups		
Timed Shutdown	1—999min		
Display	5.5-inch color touch screen,		
Power Supply	AC220V/50Hz		
Consumption	1.4KW	2.1KW	2.8KW
Package Size (W*H*D) mm	870*460*600	870*460*600	870*460*600
Net Weight (kg)	18	21	26
Gross Weight (kg)	24	28	34

Exhaust System Scrubber

Features:

- * This product is acid, alkali neutralization equipment with negative pressure pump, the air pump has large flow, long life and easy to use.
- * The three-stage absorption of lye and distilled water buffer ensures the reliability of gas exclusion.
- * The instrument is simple, safe and reliable to use.
- * The replacement of neutralization solution is convenient and easy to operate.



Technical Parameters:

Model	ES1B
Extraction Flow	18L / min
Air Extraction Interface	Φ8-10mm (Reducer fittings are available)
Alkaline Solution Bottle	1L
Distilled Water Bottle	1L
Alkali Concentration	10%--35%
Power Supply	AC220V/50Hz
Consumption	120W
Package Size (W*H*D) mm	470*480*450
Gross Weight (kg)	15

Gas Collection Hood

Features:

- * The sealing cover is made of polytetrafluoroethylene, resistant to high temperature, strong acid and alkali.
- * The collecting tube collects acid gas deep inside the tube with high reliability.
- * It is designed as a conical plus cap structure, and each seal cap weighs 35g.
- * Using gravity seal, sealing reliable and convenient.
- * The shell is welded with 316 stainless steel plate, which has good corrosion resistance.



Technical Parameters:

Model	GCH-08	GCH-10	GCH-15	GCH-20
Collecting Port	8	10	15	20
Air Extraction Port	1	1	2	2
Apply	BKD-8B	BKD-10RS BKD-10RL	BKD-15RS BKD-15RL	BKD-20RS BKD-20RL
Package Size(W*H*D)mm	400*300*300	350*260*260	350*260*260	350*260*260
Gross Weight(kg)	3	3	4	4.2

Ultrasonic Cleaner



Introduction:

Ultrasonic cleaner is a non-polluting, non-damaging, multi-purpose cleaning equipment. It not only has a powerful cleaning effect on objects with complex shapes, but also accelerates dissolution and emulsification. Ultrasonic cleaner has the unparalleled advantages of other physical cleaning or chemical cleaning, and is widely used in service industry, electronics industry, pharmaceutical industry, laboratory, machinery industry, cemented carbide industry, chemical industry and other fields.

Features:

- * Standard accessories: 1pc of soundproof cover, 1pc of basket, 1pc of PVC pipe.
- * The shell and inner cavity are made of 304 stainless steel, which is anti-corrosion.
- * LED display for UC-VAD series.

Technical Parameters:

Model	UC-18VAD	UC-24VAD	UC-36VAD	UC-48VAD	UC-60VAD
Capacity(L)	6.5	10	15	22.5	30
Ultrasonic Frequency	Double Frequency, 28/40kHz				
Time Range/ Heating Temperature	1-99min/RT~80°C				
Ultrasonic Power	180W	240W	360W	480W	600W
Heating Power	500W				
Power Supply	220V 50Hz				
Tank Size(mm)	300*150*150	300*240*150	330*300*150	500*300*150	500*300*200
External Size(mm)	330*180*310	330*270*310	360*330*310	530*330*310	530*330*350
Packing Size(mm)	440*280*355	440*360*355	475*415*380	640*415*380	640*415*425
Gross Weight(kg)	7	9	11	14	17

* Remark: VAD is based on the digital AD model and adds another frequency of 28kHz.

Introduction:

Ultrasonic cleaner is a non-polluting, non-damaging, multi-purpose cleaning equipment. It not only has a powerful cleaning effect on objects with complex shapes, but also accelerates dissolution and emulsification. Ultrasonic cleaner has the unparalleled advantages of other physical cleaning or chemical cleaning, and is widely used in service industry, electronics industry, pharmaceutical industry, laboratory, machinery industry, cemented carbide industry, chemical industry and other fields.

Features:

- * Standard accessories: 1pc of soundproof cover, 1pc of basket, 1pc of PVC pipe.
- * The shell and inner cavity are made of 304 stainless steel, which is anti-corrosion.
- * LED display for UC-AD series.

Technical Parameters:

Model	UC-18AD	UC-24AD	UC-36AD	UC-48AD	UC-60AD
Capacity(L)	6.5	10	15	22.5	30
Ultrasonic Frequency	Single Frequency, 40kHz				
Time Range/ Heating Temperature	1-99min/RT~80°C				
Ultrasonic Power	180W	240W	360W	480W	600W
Heating Power	500W				
Power Supply	220V 50Hz				
Tank Size(mm)	300*150*150	300*240*150	330*300*150	500*300*150	500*300*200
External Size(mm)	330*180*310	330*270*310	360*330*310	530*330*310	530*330*350
Packing Size(mm)	440*280*355	440*360*355	475*415*380	640*415*380	640*415*425
Gross Weight(kg)	7	9	11	14	17

* Remark: The AD model is a digital power adjustable model, which adds a power adjustable function based on the digital model(D model).

Ultrasonic Cleaner



UC-18D/UC-24D/
UC-36D/UC-48D/
UC-60D



UC-18J/UC-24J/
UC-36J/UC-48J/
UC-60J



Basket

Introduction:

Ultrasonic cleaner is a non-polluting, non-damaging, multi-purpose cleaning equipment. It not only has a powerful cleaning effect on objects with complex shapes, but also accelerates dissolution and emulsification. Ultrasonic cleaner has the unparalleled advantages of other physical cleaning or chemical cleaning, and is widely used in service industry, electronics industry, pharmaceutical industry, laboratory, machinery industry, cemented carbide industry, chemical industry and other fields.

Features:

- * Standard accessories: 1pc of soundproof cover, 1pc of basket, 1pc of PVC pipe.
- * The shell and inner cavity are made of 304 stainless steel, which is anti-corrosion.
- * LED display for UC-D series.

Technical Parameters:

Model	UC-18D	UC-24D	UC-36D	UC-48D	UC-60D	UC-18J	UC-24J	UC-36J	UC-48J	UC-60J
Capacity (L)	6.5	10	15	22.5	30	6.5	10	15	22.5	30
Ultrasonic Frequency	Single frequency, 40 kHz									
Time Range/ Heating Temp	1~99min/RT ~80°C					1~60min/RT ~80°C				
Ultrasonic Power (W)	180	240	360	480	600	180	240	360	480	600
Heating Power (W)	500									
Power Supply	AC220V, 50Hz									
Tank Size (mm)	300*150*	300*240*	330*300*	500*300*	500*300*	300*150*	300*240*	330*300*	500*300*	500*300*
External Size (mm)	330*180*	330*270*	360*330*	530*330*	530*330*	330*180*	330*270*	360*330*	530*330*	530*330*
Packing Size (mm)	430*250*	430*340*	460*400*	640*400*	640*400*	430*250*	430*340*	460*400*	640*400*	640*400*
Gross Weight (kg)	6	8	10	13	15	6	8	10	13	15

* Remark: The J model is a mechanical model, with the heating time and working time controlled by a knob.
The D model is a digital model, with the heating temperature and working time controlled by a button.

Double Adjustable Frequencies Type



UC-30SDG/UC-50SD
/UC-60ST/UC-70ST



UC-20SD/UC-30SD



UC-20SDII



UC-30SDII

Features:

- * Over-voltage and over-current protection.
- * Standard: 1pc of basket, 1pc of lid.
- * Low-level water protection.
- * Fully microprocessor controlled and programmable.
- * Digital display, easy setting for time and temperature.
- * Time and temperature real-time display.
- * Standard Power Supply: AC220V±10%, 50/60Hz; 110V±10%, 60Hz (Except for UC-10SDII, UC-20SD, UC-20SDII, UC-30SD).

Technical Parameters:

Model	Capacity (L)	Adjustable Ultrasonic Frequency (KHz)		Time Range /Heating Temp	Ultrasonic Power(W)	Heating Power(W)	Tank Size L*W*H(mm)	Packing Size L*W*H(mm)	Gross Weight(kg)
UC-30SDG	13	45	80	1~480min /0~80°C	300	400	300*240*180	840*670*730	73
UC-50SD	27	45	80		500	800	500*300*180	1100*690*800	101
UC-60ST	27	45	80		600	800	500*300*180	1100*690*800	102
UC-70ST	27	45	80		700	800	500*300*180	1100*690*800	104
UC-20SD	6	45	80	1~480min /RT~80°C	200	400	300*150*150	445*250*430	9.5
UC-20SDII	8	45	80		200	400	300*150*180	500*350*480	15.5
UC-30SD	10	45	80		300	400	300*240*150	446*346*483	12.5
UC-30SDII	13	45	80		300	400	300*240*180	650*540*630	37

Single Frequency Type



UC-20SII



40KHz



UC-30SII/UC-50S/UC-60S/UC-70S



UC-10S/UC-20S/UC-30S

Introduction:

Ultrasonic cleaning is a process that uses, ultrasonic and an appropriate cleaning, solvent to clean items.

Features:

- * Standard: 1pc of basket, 1pc of lid.
- * Time and temperature real-time display.
- * Fully microprocessor controller and programmable.
- * Digital display, easy operation for time and temperature.
- * Low-level water protection (UC-20S, UC-20SII, UC-30S, UC-30SII, UC-50S, UC-60S, UC-70S).
- * Standard Power Supply: AC220V±10%, 50/60Hz; 110V±10%, 60Hz (Except for UC-10S, UC-20S, UC-20SII).

Technical Parameters:

Model	Capacity (L)	Ultrasonic Frequency	Time Range /Heating Temp	Ultrasonic Power(W)	Heating Power(W)	Tank Size L*W*H(mm)	Packing Size L*W*H(mm)	Gross Weight(kg)
UC-08A	1.3	40KHz	1~99min/20~80°C	60	200	150*140*65	260*260*260	2.5
UC-10A	2			60	200	150*140*100	260*260*290	3
UC-20A	3			120	200	240*135*100	350*260*330	4
UC-50A	14			300	400	300*240*200	430*370*430	9
UC-70A	19			420	600	330*300*200	460*430*430	11
UC-10S	4	80KHz	1~480min /RT~80°C	100	400	300*150*100	445*250*400	8.5
UC-20S	6			200	400	300*150*150	435*240*430	8.8
UC-20SII	8			200	400	300*150*180	505*355*495	13
UC-30S	10			300	400	300*240*150	446*346*463	12.1
UC-30SII	13		300	400	300*240*180	840*670*730	75	
UC-50S	27		1~480min /0~80°C	500	800	500*300*180	1100*690*820	99
UC-60S	27			600	800	500*300*180	1100*690*820	101
UC-70S	27			700	800	500*300*180	1100*690*820	101

Shaker

Decolorization Shaker



SK-D700
Intelligent 3D Shaker



SK-R800
Intelligent Rocking Shaker



SK-O900
Intelligent Orbital Shaker



SK-L108
Intelligent Linear Shaker

Introduction:

Decolorization shaker is widely used for the fixation of electrophoresis gel separation band, the oscillations of Coomassie blue staining and decolorization, the fixation, staining, development of silver nitrate staining, the development and fixing of X-ray film in the autoradiography experiment, further processing of cellulose film after electrophoretic transfer, the reaction and staining of antigen, molecular hybridization and cell culture, etc. The decolorizing shaker can be used in any experiment where the sample needs to be shaken in the solution.

It can be used in environmental monitoring, medical health, petrochemical, food, metallurgy, PCR laboratory preparation and preparation. It is suitable for laboratories of various colleges and universities, scientific research and production enterprises.

Features:

- * Molded natural rubber platform can effectively prevent the corrosion of the machine by accidentally overflowing acid and alkali solution, acid and alkali resistance, no deformation, beautiful and durable, easy to clean.
- * Easy to achieve timing, setting speed and continuous operation mode.
- * Intelligent speed control: microcomputer control of high-precision stepper/ brushless DC motor, intelligent feedback control, improving the control speed accuracy, and not affected by power supply voltage fluctuations.
- * Intelligent low speed start: gradual accelerate start, to avoid the sample liquid outward caused by sudden high-speed start, sample damage, while extending the life of mechanical parts.
- * With memory function in case of power-failure.
- * The operation is durable and stable, can work for more than 18 hours continuousl.
- * Parameter modification online: the parameters can be modified in real time under the running state.
- * Overload protection: it will stop running when overloaded to ensure instrument life and safety.
- * LCD display, real-time display of all operating parameters.
- * The control system ensures smooth start-up, smooth acceleration, and uniform movement of the test sample.
- * The shape has a streamlined style and aesthetic design concept

Technical Parameters:

Model	SK-D700	SK-R800	SK-O900	SK-L108
Display	LCD Color Display			
Rotary Speed	10~100rpm		30~300rpm	30~240rpm
Rotary Accuracy	±1rpm			
Amplitude	Inclination 9°	Up and down 25mm	Circumference Dia. 20mm	Circumference Dia. 30mm
Oscillation Mode	3D/universal motion	Swing up and down motion	Horizontal cyclotron motion	Linear reciprocating motion
Timing Range	0~99.59h		0~1999min	
Tray	320*320mm	280*280mm	320*320mm	
Max. Load	5kg			
Motor	High precision stepper motor		Brushless DC motor	
Power Supply	AC200~240V, 50/60HZ			
External Size	335*400*245mm	280*350*195mm	340*400*175mm	340*400*170mm
Net Weight	15kg	10kg	22kg	
Package Size	518*456*365mm	470*398*300mm	518*456*365mm	
Gross Weight	18kg	13kg	25kg	

Table Top Capacity Shaker



Introduction:

The shaker has a simple and elegant appearance, various functions, and gentle vibration. It is suitable for the mixing of various substances in a specific constant temperature room with centralized constant temperature and cluster vibration. Oscillating efficiency for pilot and high-volume strain screening in production operations and biopharmaceutical research applications. Suitable for fields such as biology, microbiology and medical analysis.

Application:

Suitable for food processing, bacterial culture, agriculture and forestry institutes, pharmaceutical factories, etc.

Features:

- * Oscillating speed 30~300rpm.
- * LCD display real-time displays time and speed.
- * Timing or continuous operation mode are optional.
- * Compact structure and small footprint.
- * DC brushless motor drive, quiet and smooth operation.
- * With safe speed protection function.
- * A variety of fixtures are available.
- * Automatic running and stop, with parameter memory and speed storage function.
- * Equipped with DC brushless motor, long service life, maintenance free.
- * The oscillator starts slowly and accelerates smoothly to ensure the safety of the experimental sample.

Technical Parameters:

Model	BK-YC30
Amplitude	26mm
Oscillation	Rotatory shaking
Display	LCD
Shaking Plate Size	680*500mm, 1 pcs
Default Capacity	250ml*24
Optional Capacity	250ml*24/500ml*18/1000ml*14/2000ml*7
Max. Capacity	100ml*49/250ml*36/500ml*24/1000ml*20/2000ml*12
Speed Range	30~300rpm
Speed Accuracy	±1rpm
Timing Range	0~999min
Power Supply	AC110~220V, 50/60Hz
Consumption	100W
External Size(W*D*H)	680*565*245mm
Net Weight	73kg
Package Size (W*D*H)	820*700*490mm
Gross Weight	83kg

Orbital and Linear Shaker

Digital orbital and linear shaker is suitable for mixing in culture dishes, flasks and beakers.



Features:

- * Double LCDs for independent display of time and speed.
- * Over speed detection and protection.
- * Different platforms and fixtures for selection.
- * Remote function provides PC control and data transmission.

Technical Parameters:

Model	SK-O330-Pro	SK-L330-Pro	SK-O180-Pro	SK-L180-Pro
Item No.	8032220100	8032120100	8032210100	8032110100
Shaking Motion	Orbital	Linear	Orbital	Linear
Orbital Diameter	10mm	/	4mm	/
Amplitude	/	10mm	/	4mm
Max. Shaking Weight (with attachment)	7.5kg		2.5kg	
Motor Type	Brushless DC motor			
Motor Input	28W			
Motor Output	15W			
Speed Range	100-500rpm	100-350rpm	100-800rpm	100-350rpm
Speed And Timer Display	LCD			
Time Range	1~1199min			
Operation Mode	Continuous/timed operation			
Working Environment	5~40°C, 80%RH			
Protection Type	IP21			
Connection Interface	RS232			
Consumption	30W			
Power Supply	100~240V, 50/60Hz			
Standard Accessory	1pc SK330.1 universal attachment		1pc SK180.1 universal attachment	
External Size(W*D*H)	420*370*100mm		340*300*100mm	
Package Size(W*D*H)	600*500*230mm (shaker)		450*450*170mm (shaker)	
	450*350*260mm (accessories)		450*350*260mm (accessories)	
Gross Weight	15kg (shaker), 3kg (accessories)		10kg (shaker), 3kg (accessories)	

3D and Rocking Shaker

3D shaker and Rocking shaker are suitable for mixing applications in wide fields including, gel staining and destaining, washes, hybridisations, immune precipitation and Western blots etc.

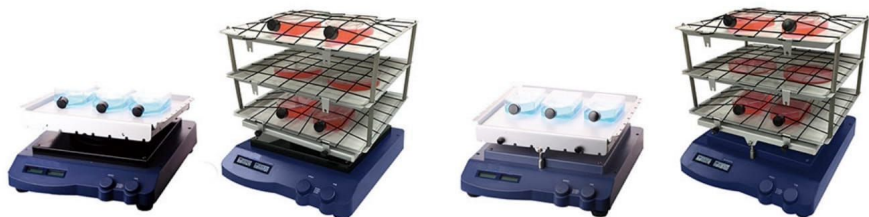

SK-D3309-Pro

SK-R330-Pro

Features:

- * Double LCDs for independent display of time and speed.
- * Different platforms and fixtures for selection.
- * 3D shaker: gentle 3D motion with fixed angle 9°; Rocking shaker: smooth see-saw rocking motion with fixed angle 9°.
- * Wide range of platforms for use with a variety of vessels.

Technical Parameters:

Model	SK-D3309-Pro	SK-R330-Pro
Item No.	8032422100	8032320100
Rocking Motion	3D orbital	See-saw rocking
Angle	9°	
Max. Load Capacity (With Wttachment)	5kg	10kg
Motor Type	DC motor	
Speed Range	10~70rpm	
Speed And Timer Display	LCD	
Time Range	1~1199min	
Operation Mode	Continuous/ timed operation	
Working Environment	5-40°C, 80%RH	
Motor Input	IP21	
Motor Output	40W	
Protection Type	24W	
Consumption	50W	
Power Supply	100~240V, 50/60Hz	
Standard Accessory	1pc SK330.5 petri dish platform	
External Size(W*D*H)	360*430*106mm	360*410*200mm
Package Size(W*D*H)	540*480*370mm	540*480*340mm
Gross Weight	16kg	15kg

Optional Accessories:



Cat. No.	18900027	18900040	18900155	18900028	18900025	18900038	18900185	18900026	18900200
Model	SK330.1	SK330.3	SK330.5	SK330.2	SK180.1	SK180.3	SK180.4	SK180.2	SK180.6
Descriptions	Universal attachment with 4 bars	Lengthways roller attachment	Petri dish platform with non-slip mat and fixed string (8 pcs)	Fixing clip attachment	Universal attachment with 3 bars	Lengthways roller attachment	Petri dish platform with non-slip mat	Fixing clip attachment	Dish attachment with non-slip mat
Size(W*D):	320*320mm	320*320mm	300*285mm		250*245mm	250*245mm	240*215mm		280x280mm

Used with Shakers									
SK-R330-Pro	√	√	√	√	/	/	/	/	/
SK-D3309-Pro	√	√	√	√	/	/	/	/	/
SK-O330-Pro/ SK-L330-Pro	√	√	√	√	/	/	/	/	/
SK-O180-Pro/ SK-L180-Pro	/	/	/	/	√	√	√	√	√



Cat. No.	18900029	18900030	18900031	18900032	18900033	18900036	18900037	18900280
Descriptions	Fixing clip for flask volume 25ml, used with SK330.2 (56pcs)&SK 180.2 (36pcs)	Fixing clip for flask volume 50ml, used with SK330.2 (28pcs)&SK 180.2 (18pcs)	Fixing clip for flask volume 100ml, used with SK330.2 (28pcs) & SK180.2 (18pcs)	Fixing clip for flask volume 200ml/250ml, used with SK330.2 (13pcs) & SK180.2 (8pcs)	Fixing clip for flask volume 500ml, used with SK330.2 (9pcs) & SK180.2 (8pcs)	Bar for SK330.1 universal attachment	Bar for SK180.1 universal attachment	Connect sticks for double dishes shaker

Used with Shakers								
SK-R330-Pro	√	√	√	√	√	√	/	√
SK-D3309-Pro	√	√	√	√	√	√	/	√
SK-O330-Pro/ SK-L330-Pro	√	√	√	√	√	√	/	√
SK-O180-Pro/ SK-L180-Pro	√	√	√	√	√	/	√	√

Table Top Large Capacity Shaker



Application:

BJPX-SZ10 is often used in liquid shaking, culture of microorganisms, bacteria and cells and other tests.

Features:

- * Intelligent sound and light alarm microprocessor controller.
- * LCD display shows the set parameters and measured parameters, easy to operate.
- * Running parameter memory function to avoid tedious operation.
- * Microcomputer control brushless DC motor accurately.
- * Power off recovery function, automatically restore operation according to the original setting program.

Technical Parameters:

Model	BJPX-SZ10
Shaking Mode	Rotary shaking
Display	LCD
Rotating Speed	30~300rpm
Rotating Accuracy	±1rpm
Vibration Range	26mm
Timing Range	0~9999min(h)
Tray Size	680*500mm
Tray Number	1pc
Flask Clamp	Standard: 24*250ml/ 18*500ml/ 14*1000ml/ 7*2000ml Max: 35*250ml/ 24*500ml/ 20*1000ml/ 12*2000ml
Power Supply	110~220V, 50/60Hz
Consumption	80W
External Size(W*D*H)	570*680*290mm
Package Size(W*D*H)	700*760*470mm
Net Weight	76.5kg
Gross Weight	87kg

Table Top Small Capacity Shaker

Application:

Suitable for food processing, bacterial culture, agriculture and forestry institutes, pharmaceutical factories, etc.

Feature:

- * Intelligent sound and light alarm, microprocessor controller.
- * The LCD display shows the set parameters and the measured parameters, which is easy to operate.
- * Running parameter memory function to avoid tedious operation.
- * DC brushless motor design, long service life and maintenance-free.
- * With the power-off memory function, the equipment can automatically resume operation according to the original set program after the external power supply suddenly loses power and then calls again.
- * The acceleration control circuit ensures that the oscillator starts slowly, accelerates smoothly, and ensures the safety of the experimental samples.



Technical Parameters:

Model	BJPX-SZ11
Amplitude	50mm
Oscillation	Rotatory shaking
Display	LCD
Shaking Plate Size	680*500mm
Default	250ml*24
Standard Capacity	250ml*24/500ml*18/1000ml*14/2000ml*7
Max. Capacity	250ml*35/500ml*24/1000ml*20/2000ml*12
Drive Mode	Single axis balanced drive type
Speed Range	30~300rpm
Speed Accuracy	±1rpm
Ambient Temp.	15~35 °C
Stackable Number	1
Curve Programming	Fixed value control speed
Timing Range	0~9999min/hour
Power Supply	AC110~220V 50/60HZ
Consumption	80W
External Size(W*D*H)	680*570*300mm
Net Weight	95.5kg
Package Size (W*D*H)	760*700*470
Gross Weight	117.5kg

Optional Clamp:

Model	BJPX-SZ11	
Triangular beaker Max. capacity (pcs)	100ml	48
	250ml	35
	500ml	24
	1000ml	20
	2000ml	12
Tube Rack (pcs)	3000ml	8
		4
96-well Plates		18
Clip-type Shaking Plate		2

Note: This table is the maximum optional capacity, please choose according to your requirement.

Optional shaker accessories



Flask Clamp



Tube Rack



Microplate/96-well plate



Universal attachment with 3 bars



Universal spring plate

Technical Parameters:

No.	Material code	Name	No.	Specifications	Note
1	18.01.09.00001	Flask Clamp	BS-A10	50ml	Common Type
2	18.01.09.00002		BS-A11	100ml	
3	18.01.09.00003		BS-A12	150ml	
4	18.01.09.00004		BS-A13	200ml	
5	18.01.09.00005		BS-A14	250ml	
6	18.01.09.00006		BS-A15	500ml	
7	18.01.09.00007		BS-A16	1000ml	
8	18.01.09.00008		BS-A17	2000ml	
9	18.01.09.00009		BS-A18	3000ml	
10	18.01.09.00010		BS-A19	5000ml	
11	18.01.09.00011	Tube Rack	BS-A20	54*10ml	Optional: Common Type
12	18.01.09.00012		BS-A21	54*15ml	
13	18.01.09.00013		BS-A22	28*50ml	
14	18.01.09.00014		BS-A23	24*100ml	
15	18.01.09.00015		BS-A24	54-well, suitable for Φ15*150centrifuge tubes.	

No.	Material code	Name	No.	Specifications	Note
16	18.01.09.00016	Tube Rack	BS-A25	54-well, suitable for Φ18*180 centrifuge tubes.	Optional: Common Type
17	18.01.09.00017		BS-A26	54-well, suitable for Φ20*200 centrifuge tubes.	
18	18.01.09.00018		BS-A27	32-well, suitable for Φ25mm*200mm centrifuge tubes.	
19	18.01.09.00019		BS-A28	28-well, suitable for Φ30mm*200mm centrifuge tubes.	
20	18.01.09.00020		BS-A50	54*7ml	
21	18.01.09.00021		BS-A51	54*10ml	
22	18.01.09.00022		BS-A52	54*20ml	
23	18.01.09.00023	BS-A53	54*30ml		
24	18.01.09.00024	Microplate/96-well plate	BS-A30	130*87*52mm	
25	18.01.09.00025	Universal attachment with 3 bars	BS-A40	320*300*70mm	suitable for 2000ml or larger beakers.
26	23.02.09999	Horizontal thermostatic shaker spring plate	SW20	900*470mm	suitable for BJPX-SW10 BJPX-SW10-L BJPX-SW20 BJPX-SW20-L
27	23.02.10000	Universal Spring plate	SDT10	420*400mm	suitable for BJPX-SDT10 BJPX-SDT20 BJPX-SDL10 BJPX-SDL20
28	23.02.10002	Universal spring plate	SDL20	460x450mm (One layer spring plate, two layer flask clamp)	suitable for BJPX-SDL10 BJPX-SDL20 BJPX-SDT10 BJPX-SDT20
29	23.02.10003	Universal spring plate	SDW10	720*490mm	suitable for BJPX-SDW10 BJPX-SDW10-L BJPX-SDW20 BJPX-SDW20-L
30	23.02.09013	Universal Spring plate	ST10	562*343mm	suitable for BJPX-ST10 BJPX-ST11 BJPX-ST20
31	23.02.09014		ST10-L	202*202mm	suitable for BJPX-ST10-L BJPX-ST11-L
32	23.02.09016	Universal Spring plate	SL20-L	446*393mm(Upper and lower spring plate)	suitable for BJPX-SL20-L BJPX-SL20
33	23.02.10004	Double-Layer flask plate	SL20-L2	446*393mm(Upper and lower Flask Clamp)	suitable for BJPX-SL20-L BJPX-SL20
34	23.02.09017	Universal Spring plate	SZ10	682*502mm	suitable for BJPX-SZ10 BJPX-SZ11

Table Top Small Capacity Shaker



SK-830F



SK-851/SK-871/SK-881F

Applications:

It is widely used in bacterial culture, fermentation, hybridization, biochemical reaction, enzyme and cell tissue research in the pharmaceutical industry. It has extensive and major applications in research and application fields such as medicine, biology, molecular science, pharmacy, food, and environment.

Features:

- * Incoming call recovery function.
- * Equipped with high-quality servo motor, the control speed is accurate, the high and low speed performance is good, and the stability is strong.
- * Ultra-low speed start function, adjustable start speed. The speed-up control circuit is adopted to start slowly and accelerate steadily to ensure the safety of experimental samples.

Technical Parameters:

Model	SK-851	SK-871	SK-830F	SK-881F
Controller	PID			
Display	LCD			
Shaking Mode	Rotatory shaking		Reciprocating shaking	
Drive Mode	Multidimensional drive		Track drive	
Rotating Speed	20-300rpm/min	20~150rpm/min	20~260rpm/min	
Rotating Accuracy	±1rpm			
Vibration Range	Φ50mm	Φ26mm	0-50mm	
Timing Range	0-9999h/min			
Shaking Plate Size	800*600mm	950*730mm	460*380mm	800*600mm
Standard Capacity	1000ml*18	1000ml*30	250ml*16	1000ml*18
Max. Capacity (Flask clamp)	250ml*48 or 500ml*33 or 1000ml*20	250ml*80 or 500ml*53 or 1L*30 or 2L*20 or 3L*12	100ml*22 or 250ml*16 or 500ml*8	250ml*48 or 500ml*33 or 1000ml*20
Max. Capacity (Sticky board)	250ml*48 or 500ml*32 or 1000ml*20	250ml*71 or 500ml*53 or 1L*30 or 2L*20 or 3L*12	100ml*20 or 250ml*20 or 500ml*9	250ml*48 or 500ml*32 or 1000ml*20
Consumption	200W	300W	80W	200W
Power Supply	220V±10%, 50/60Hz (Standard); 110V±10%, 60Hz (Optional)			
External Size (W*D*H)mm	900*650*600	1040*760*595	460*410*250	900*650*600
Package Size (W*D*H)mm	1050*800*795		600*480*335	1050*800*795
Gross Weight	290kg		40kg	290kg

Table Top Large Capacity Shaker



Applications:

It is widely used in bacterial culture, fermentation, hybridization, biochemical reaction, enzyme and cell tissue research in the pharmaceutical industry. It has extensive and major applications in research and application fields such as medicine, biology, molecular science, pharmacy, food, and environment.

Features:

- * Ultra-low speed start function, the start speed is adjustable.
- * Restore function after power on.
- * Equipped with high-quality servo motor, the control speed is accurate, the high and low speed performance is good, and the stability is strong.
- * The speed-up control circuit is adopted to start slowly and accelerate steadily to ensure the safety of experimental samples.

Technical Parameters:

Model	SK-852	SK-872	SK-882F
Controller	PID		
Display	LCD		
Circulation Mode	Natural convection		
Shaking Mode	Rotatory shaking		
Drive Mode	Multi-dimensional drive		
Rotating Speed	20-300rpm	20-150rpm	20-260rpm
Rotating Accuracy	±1rpm		
Vibration Range	Φ50mm	Φ26mm	
Timing Range	0-9999h/min		
Shaking Plate Size	800*600mm	950*730mm	800*600mm
Shaking Plate Quantity	2pcs		
Standard Capacity (Flask Clamps Qty)	250ml*46 & 1000ml*18	250ml*71 & 1000ml*30	250ml*46 & 1000ml*18
Optional Flask Clamps	250ml*96 or 500ml*66 or 1000ml*40	250ml*160 or 500ml*106 or 1000ml*60 or 2000ml*40 or 3000ml*24	250ml*96 or 500ml*66 or 1000ml*40
Optional Sticky Board	250ml*96 or 500ml*64 or 1000ml*40	250ml*142 or 500ml*106 or 1000ml*60 or 2000ml*40 or 3000ml*24	250ml*96 or 500ml*64 or 1000ml*40
External Material	Cold-rolled steel with anti-bacterial powder coating		
Consumption	200W	300W	200W
Power Supply	220V±10%, 50/60Hz (Standard); 110V±10%, 60Hz (Optional)		
External Size(W*D*H)	900*650*900mm	1040*760*1050mm	900*650*900mm
Packing Size(W*D*H)	1110*800*1155mm		
Gross Weight	350kg		

Mixer Long Axis Rotary Mixer



Application:

BHY-100 mixer is a test tube mixer with adjustable speed and a combination of functions such as rotation, flipping, shaking, etc. It can provide efficient and gentle mixing to keep biological samples in suspension. It is suitable for various test tubes. It is suitable for applications such as blood coagulation prevention, latex diagnosis, immunoprecipitation, and mixing of liquid substances.

Features:

- * LCD display speed and time.
- * Electronically adjust speed and time for more precise control.
- * A variety of modules are optional to meet different needs.
- * Some modules are suitable for virus sampling tubes.

Technical Parameters:

Model	BHY-100
Speed Range	9~100rpm
Time Setting Range	1min~99h
Motor Input	17W
Power Supply	100~250V, 50/60Hz
Standard Accessory	BHY-100-08
External Size (W*D*H)	485*199*207mm
Package Size (W*D*H)	530*230*290mm
Gross Weight	11kg

Accessories:

Type	Sample Capacity	Type	Sample Capacity
BHY-100-01	Horizontally install 16 10ml or 15ml centrifuge tubes, or 16 5ml or 10ml virus sampling tubes	BHY-100-06	Vertically install 32 5ml centrifuge tubes, or 32 5ml virus sampling tubes (pick one of two)
BHY-100-02	Vertically install 12 10ml or 15ml centrifuge tubes, or 12 5ml or 10ml virus sampling tubes	BHY-100-07	Horizontally install 16 50ml centrifuge tubes
BHY-100-03	Horizontally install 40 1.5ml or 2ml centrifuge tubes	BHY-100-08 (standard)	Vertically install 12 50ml centrifuge tubes
BHY-100-04	Vertically install 44 1.5ml or 2ml centrifuge tubes	BHY-100-09	Horizontally install 16 centrifuge tubes (1.5ml/2ml/5ml/10ml/15ml/50ml, random combination)
BHY-100-05	Horizontally install 40 5ml centrifuge tubes	BHY-100-10	Vertically install 16 centrifuge tubes (1.5ml/2ml/5ml/10ml/15ml/50ml, random combination)

Multi-Tube Vortex Mixer

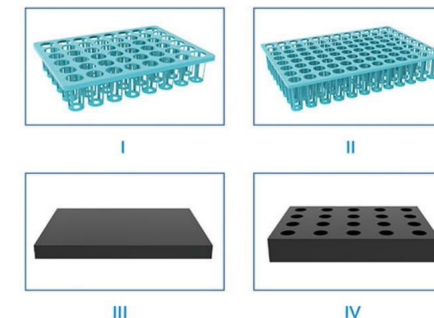

Features:

- * Up to 96 samples can be processed at one time, and the rotation speed can reach 2500rpm.
- * Run time and pause time can be set.
- * Configure various types of sponge test tube racks.
- * Button-type jog mode, double switch design.
- * Power-off memory function, saving setup time.
- * Accelerates uniformly, effectively avoiding sample splashing.
- * Three working modes of jog, continuous and intermittent pulse can be selected at will.
- * LED display speed and time, simple operation panel, precise control by microprocessor.

Technical Parameters:

Model	BHY-2500
Speed Range	500~2500rpm
Speed Regulation Accuracy	±1rpm
Amplitude	3.6mm
Time Setting Range	1s~99h59min
Pulse Interval Timing Range	1s~99s
Pulse Operation Timing Range	1s~99min59s
Consumption	120W
Power Supply	100~230V, 50/60Hz
Standard Accessory	I, II, III, IV
External Size (L*W*H)	438*301*429mm
Package Size (W*D*H)	530*380*510mm
Gross Weight	27kg

Accessories:

Model	Pore Diameter	Compatible Type	Size
I	48-Well Virus Sampling Tube Rack	20ml or 30ml virus sampling tube	272*205*50mm
II	96-Well Virus Sampling Tube Rack	7ml or 10ml virus sampling tube 10ml or 15ml centrifuge tube	296*202*50mm
III	Replaceable Tray Pad	/	302*212*25mm
IV	Φ25~Φ29mm	50ml centrifuge tube	300*210*45mm

Vortex Mixer



Application:

Used for liquid, liquid-solid, solid (powder) mixing, the vortex mixer can mix any liquid and powder in the form of whirlpool. The mixing speed is fast, uniform, thorough. Widely used in environmental monitoring, medical and health, petrochemical, food, metallurgy, PCR laboratory, scientific research and production enterprises laboratory, laboratory, for mixing, extraction and biological, biochemical, cell, strain and other sample oscillation culture.

Features:

- * The shell is made of high-quality ABS material, beautiful and atmospheric.
- * New type of DC brushless motor, stepless adjustment, low noise and long effect.
- * Digital display to ensure the accuracy of time and speed.
- * Time and speed adjustment response is fast, saving experiment time.
- * Solid and reliable workmanship, excellent shock absorption, suitable for high-speed operation.
- * A variety of models and accessories are available.

Technical Parameters:

Model	BJPX-VW
Speed/Accuracy	200-3000rpm/ ±5rpm
Timing	0-9999 min/s
Amplitude Range	4mm
Oscillation Mode	Circular motion
Working Mode	Point vibration, continuous
Control Form	Pressure sensing
External Size	155mm*200mm*155mm
Net Weight	4.0kg
Package Size	285*235*205mm
Gross Weight	4.5 kg

Accessories Technical Parameters:

Type	Item No.	Mode	Max Speed	Max Test Tube Size	Pictures	Standard/Optional
Test tube platform	XW001	Point vibration, continuous	3000rpm	Suitable for test tubes of different sizes		Standard
Flat bottom container platform	XW002	Point vibration, continuous	3000rpm	Container bottom sizes ≤ Φ80mm		Optional
Test tube holder: 19*10mm	XW003	Continuous	2000rpm	Applicable to 19 test tubes with an outer diameter of 10mm		Optional
Test tube holder: 13*12mm	XW004	Continuous	2000rpm	Suitable for 13 test tubes with an outer diameter of 12mm		Optional
Test tube holder: 12*15mm	XW005	Continuous	1400rpm	Suitable for 12 test tubes with outer diameter of 15mm		Optional
Test tube holder: 7*20mm	XW006	Continuous	1400rpm	Applicable for 7 test tubes of 20mm outer diameter		Optional
Test tube holder: 4*26mm	XW007	Continuous	1400rpm	Suitable for 4 test tubes with outer diameter of 26mm		Optional
Microplate tray	XW008	Continuous	1000rpm	Suitable for microplate with an outer dimension of 128mm*86mm		Optional
Test tube holder tray	XW009	Continuous	2000rpm	Suitable for fixing test tube holder XW003-XW007		Optional

Vortex Mixer



BK-VX1

BK-VX2

Accessories:



Bowl adapter
50ml tube



Flat type adapter
500ml or 250ml
beaker



Tray type adapter
9*50ml Centrifuge
tube

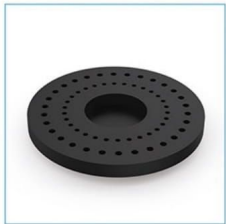

60 micro tube plate
0.5ml micro tube*30,
1.5ml micro tube*30

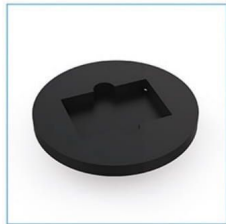

Microplate adapter
96-well microtiter
plate



Tray type adapter
11*50ml Centrifuge
tube

Introduction:

The structure of the vortex mixer is simple and reliable, and the instrument has the characteristics of small size, low power consumption, and low noise. It is widely used in biochemistry, genetic engineering, medicine and other fields. It can quickly mix any liquids and powders you need to mix in a high-speed vortex, and the mixing speed is fast, uniform and thorough.

Features:

- * Shaded pole motor, stepless speed regulation, maximum speed 2800rpm. (for BK-VX1)
- * Eccentric bearing design, cycloid mixing, uniform and fast mixing.
- * Suction cup machine feet, suitable for high-speed work.
- * A variety of vibration module adapters to choose from, suitable for a variety of containers.
- * Jog and continuous operation modes are available.

Technical Parameters:

Model	BK-VX1	BK-VX2
Shaking Mode	Orbital	
Orbital Diameter	4mm	
Motor Type	Shaded pole motor	
Speed Range	0~2800rpm	0, 2800rpm
Operation Mode	Jog, continuous, adjust the speed	Jog, continuous
Rotation Control	Stepless speed regulation	Not adjustable
Power Consumption	40W	
Working Environment	Temperature: 5-40°C; Humidity: ≤80%	
Power Supply	220V, 50/60Hz; 110V, 60Hz	
Standard Accessory	Bowl adapter, Flat type adapter	Bowl adapter
Optional Accessory	60 micro tube plate, Microplate adapter, Tray type adapter (9*50ml or 11*50ml)	Flat type adapter
External Size (W*D*H)	152*152*185mm	
Package Size (W*D*H)	250*230*220mm	
Gross Weight	3.8kg	

Roller Mixer



BK-RX6



BK-RX6F

Introduction:

Roller mixer is used for mixing blood samples, viscous substances and liquid-solid suspensions, prevention of blood coagulation and immune precipitation etc.

Features:

- * Rocking and Rolling modes for good mixing.
- * LCD displays running speed and timing time.
- * Electronic setting speed and timing time, more correct control.
- * Adjustable speed, maximum speed up to 100rpm.
- * Six roller design, suitable for a variety of sample tubes.
- * Timed or continuous operation mode.

Technical Parameters:

Model	BK-RX6	BK-RX6F
Mixing Mode	Rocking & Rolling	
Speed Range	10-100 rpm	
Rocking Amplitude	24mm	
Number of Roller	6 pcs	
Roller Length	280mm	
Max. Loading Weight	4Kg	
Operation Mode	Continuous	Continuous or timing
Speed Display	Scale	LCD
Timer	/	Yes
Timer Display	/	LCD
Timing Range	/	1min-23h59min
Motor Type	Brushless DC motor	
Applicable Specifications	Dia.6-34mm	
Consumption	25W	30W
Power Supply	110-220V, 50/60Hz	
Product Size (W*D*H)	468*250*102mm	
Packing Size (W*D*H)	531*312*186mm	
Net Weight	4kg	4.2kg
Gross Weight	5.5kg	5.5kg

Roller Mixer

Roller mixer is used for mixing blood samples, viscous substances and liquid-solid suspensions, prevention of blood coagulation and immune precipitation etc.



MX-T6-S



MX-T6-Pro

Features:

- * LCD display indicates the speed and time for MX-T6-Pro.
- * Speed range of 10-70rpm.
- * Six roller design for gentle rolling and easy to clean.

Technical Parameters:

Model	MX-T6-S	MX-T6-Pro
Item No.	8011312000	8011312100
Mixing Mode	Rocking & Rolling	
Speed Range	0~70 rpm	10~70 rpm
Rocking Amplitude	24mm	
Number of Roller	6 pcs	
Roller Length	280mm	
Max. Loading Weight	4kg	
Timing Range	/	1~1199min
Operation Mode	Continuous	Continuous or timing
Speed Display	Scale	LCD
Timer	/	Yes
Timer display	/	LCD
Motor Type	DC motor	
Ambient Temp.	5-40°C	
Relative Humidity	80%	
Protection Type	IP21	
Power Consumption	25W	30W
Power Supply	100~240V,50/60Hz	
External Size(W*D*H)	450*260*120mm	
Package Size(W*D*H)	595*390*245mm	
Gross Weight	5kg	5kg

Microplate Mixer



MX-M
With microplate clamp



MX-M
with universal top plate and
a tube adapter

Features:

- * A wide range of speed from 0 to 1500rpm.
- * Used for various mixing applications with optional adapters.
- * Maintenance-free brushless DC motor.
- * When the test tube adapter is selected, it must be matched with PS1.1.

Accessories:



Technical Parameters:

Model	MX-M
Item No.	8011202000
Shaking Mode	Orbital
Orbital Diameter	4.5mm
Max. Shaking Weight(with attachments)	0.5kg
Motor Type	DC brushless motor
Motor Input	18W
Motor Output	10W
Speed Range	0~1500rpm (single microplate) ; 0~1000rpm (double microplate)
Speed Display	Scale
Ambient Temp.	5~40°C
Relative Humidity	80%
Protection Type	IP21
Power Consumption	20W
Power Supply	100~240V,50/60Hz
Standard Accessories	18900042
External Size(W*D*H)	260*150*80mm
Package Size(W*D*H)	480*260*250mm
Gross Weight	3kg

Rotating Mixer



MX-RD-E

MX-RD-Pro

Features:

- * LCD display of speed and time(MX-RD-Pro).
- * Adjustable mixing angle from 0 to 90°(MX-RD-Pro).
- * Material of the plate: Stainless steel with oxidation coating (MX-RD-E), Stainless Steel (MX-RD-Pro).
- * Material of the clip: Plastic (MX-RD-E), Stainless Steel (MX-RD-Pro).
- * Speed range from 10 to 70rpm(MX-RD-Pro).Adjustable speed range from 0 to 80rpm(MX-RD-E).
- * A wide variety of accessories are available.

Accessories for MX-RD-Pro: (Only 18900162 is standard accessory)



Cat. No.: 18900160
Type 1 plate
60*1.5ml centrifuge tube

Cat. No.: 18900161
Type 2 plate
16*15ml centrifuge tube

Cat. No.: 18900162
Type 3 plate
8*50ml centrifuge tube

Cat. No.: 18900140
Plate support rods
4pcs in a group, use with plates

Technical Parameters:

Model	MX-RD-E	MX-RD-Pro
Item No.	8031412000	8031412100
Speed Range	0~80rpm	10~70rpm
Inclining Angle Range	/	0°~90°
Timing Range	/	1~1199min
Operation Mode	Continuous	Continuous or Timing
Display	Scale	LCD
Motor Type	DC motor	
Ambient Temp.	5-40°C	
Relative Humidity	80%	
Protection Type	IP21	
Consumption	20W	40W
Power Supply	100~240V,50/60Hz	
Standard Accessories	18900327 and 18900328 and 18900329	18900162
External Size(W*D*H)	220*300*310mm	210*280*300mm
Package Size(W*D*H)	370*450*420mm	370*410*440mm
Gross Weight	5kg	7kg

Vertical Rotating Mixer



MX-RL-E

MX-RL-Pro

Features:

- * Electronic adjustment of speed and time(MX-RL-Pro).
- * LCD display indicates the speed and time for MX-RL-Pro.
- * Speed range from 10 to 70rpm(MX-RL-Pro),adjustable speed range from 0 to 80 rpm(MX-RL-E).
- * Material of the tube holder: Stainless steel with oxidation coating (MX-RL-E), Stainless Steel (MX-RL-Pro).
- * Material of the clip: Plastic (MX-RL-E), Stainless Steel (MX-RL-Pro).
- * Three clip sizes are selectable, suit for the tubes: 1.5ml, 15ml, 50ml.
- * A wide variety of accessories are available.



Stainless steel clip
Cat No.: 18900196, for 1.5ml centrifuge tube
Cat No.: 18900197, for 15ml centrifuge tube
Cat No.: 18900198, for 50ml centrifuge tube



Plastic clip
Cat No.: 18900327, for 1.5ml centrifuge tube
Cat No.: 18900328, for 15ml centrifuge tube
Cat No.: 18900329, for 50ml centrifuge tube

Optional Tube Holder for MX-RL-Pro: (18900147 or 18900145 can be selected as the standard accessory)



Cat. No.: 18900142
For 48*1.5ml centrifuge tube
Held horizontally

Cat. No.: 18900143
For 24*15ml centrifuge tube
Held horizontally

Cat. No.: 18900144
For 24*50ml centrifuge tube
Held horizontally

Cat. No.: 18900145
For 32*1.5ml centrifuge tube
Held vertically

Cat. No.: 18900146
For 16*15ml centrifuge tube
Held vertically

Cat. No.: 18900147
For 16*50ml centrifuge tube
Held vertically

Technical Parameters:

Model	MX-RL-E	MX-RL-Pro
Item No.	8031402000	8031402100
Speed Range	0~80rpm	10~70rpm
Timing Range	/	1~1199min
Operation Mode	Continuous	Continuous or Timing
Display	Scale	LCD
Motor Type	DC motor	
Ambient Temp.	5-40°C	
Relative Humidity	80%	
Protection Type	IP21	
Consumption	20W	40W
Power Supply	100~240V,50/60Hz	
Standard Accessories	18900327 and 18900328 and 18900329	18900147 or 18900145
External Size(W*D*H)	530*150*190mm	510*220*260mm
Package Size(W*D*H)	630*310*380mm	630*310*380mm
Gross Weight	3kg	9kg

Stirrer

Hotplate Magnetic Stirrer



Features:

- * Digital temperature control, maximum temperature up to 120°C
- * The maximum speed of stepless speed regulation can reach 2600rpm
- * DC brushed motor, low noise, stable speed regulation
- * The stirring bar is made of fluorine material and high-quality magnetic steel, which has the characteristics of high temperature resistance, wear resistance, chemical corrosion resistance and strong rotation force.
- * Mixing work can be carried out in a sealed container, and the reference is simple and convenient
- * The appearance is simple and beautiful, the body is exquisite and compact, light in weight, and does not occupy the laboratory space

Technical Parameters:

Model	BK-MS120
Motor Type	DC brushed motor
Control Temp. Range	RT-120°C
Stirring Speed	0-2600rpm, stepless
Stirring Power	5W
Heating Power	250W
Temp. Display	LED
Timing Range	0-120min
Heating Platform Material	Stainless Steel
Platform Size	φ125mm
Max Capacity	3L
Temp. Sensor	NTC standard
Ambient Temp. & Humidity	5-40°C, <80%
Power Supply	100-240V 50/60Hz
External Size	240*180*110mm
Net Weight	1.8kg
Packing Size	310*260*180mm
Gross Weight	2.4kg



Features:

- * The maximum speed can reach 1600rpm
- * Stainless steel ceramic coated work plate is extremely chemical resistant
- * The external temperature sensor PT1000 can be connected to accurately control the sample temperature, and the temperature control accuracy can reach ±0.5°C
- * LED display shows temperature and speed in real time
- * Safety circuit design, automatic power off when the heating plate is overheated, to protect the safety of the laboratory
- * PID precise speed regulation, smoother speed up process, more precise speed control
- * The appearance is simple and beautiful, the body is exquisite and compact, light in weight, and does not occupy the laboratory space

Technical Parameters:

Model	BK-MS280	BK-MS340
Motor Type	DC brushless motor	
Control Temp. Range	RT-280°C	RT-340°C
Stirring Speed	150-1600rpm	
Stirring Power	5W	
Heating Power	550W	600W
Temp. Display	LED	
Rotation Display	LED	
Heating Platform Material	Stainless Steel with ceramic coating	
Platform Size	φ135mm	
Max Capacity	3L	
Temp. Sensor	PT1000, standard	
Ambient Temp. & Humidity	5-40°C, <80%	
Power Supply	100-240V 50/60Hz	
External Size	280*175*105mm	
Net Weight	3.4kg	
Packing Size	360*260*180mm	
Gross Weight	4kg	

Hotplate Magnetic Stirrer



Features:

- * The heating plate is treated with ceramic, which is corrosion-resistant, easy to clean and has a long service life.
- * Use brushless DC motor; low noise and long life
- * The stirrer adopts high-temperature resistant and strong magnet.
- * The body is made of high-quality materials and the polymer high-temperature-resistant shell is durable.

Technical Parameters:

Model	BJPX-SC10-2
Disk Material	Aluminum disc ceramic coating
Working Surface Size	170*170mm
Motor Type	Brushless DC motor
Maximum Mixing Capacity	3L
Rotation Range	0-2000rpm
Temperature Control Range	RT-100°C
Temperature Display Resolution	0.1°C
Temperature Control Resolution	1°C
Temperature Sensor	PT100 (Standard)
Heating Power	360W
Motor Power	5W
Power Supply	Standard: 220V/50Hz; optional: 110V 60Hz
Machine Size (mm)	305*176*120
Net Weight (kg)	2.5
Packing Size (mm)	370*240*180
Gross Weight (kg)	3.2



Features:

- * Use ceramic heating plate, corrosion-resistant, easy to clean, long service life
- * Use brushless DC motor; low noise and long life
- * The stirrer adopts high temperature resistance and strong magnetism.
- * The body is made of high-quality materials and the polymer high-temperature-resistant shell is durable.
- * With timing, forward and reverse, locking and other functions

Technical Parameters:

Model	BJPX-SC11-Pro
Disk Material	Ceramic coated aluminum disc
Working Surface Size	φ140mm
Motor Type	Brushless DC motor
Maximum Volume	5L
Rotation Range	100-1500rpm
Display	LED
Temperature Control Range	RT-300°C
Temperature Control Method	PID control
Temperature Display Resolution	0.1°C
Temperature Control Accuracy	±1°C
Temperature Sensor	PT100 (Standard)
Waste heat high temperature alarm	>50°C
Heating Power	300W
Motor Power	9W
Power Supply	AC100-230V 50/60Hz
Timing Range	0-99h59min
Machine Size (mm)	250*150*95
Net Weight (kg)	1.3
Packing Size (mm)	300*200*150
Gross Weight (kg)	2.2

Hotplate Magnetic Stirrer



MS-H-10



MS-H-11

Features:

- * Built-in temperature control system.
- * The temperature and rotation speed can be accurately set through the digital display screen, and the temperature control range is wide.
- * Rubber feet support, more stable.
- * Configure temperature sensor PT100.
- * With relay over temperature protection alarm, safe and convenient.

Technical Parameters:

Model	MS-H-10	MS-H-11
Working Plate Size	200*200mm	φ150mm
Platform Material	Aluminum, anodized	
Motor Type	DC brushless motor	
Number of Stirring Points	1	
Maximum Stirring Volume (water)	20L	
Stirrer Maximum Size	50mm	
Rotation Range	20-2000r/min	
Data Display	LED	
Heating Temperature Range	Room temperature~360.0°C	
Overheating Protection	360~400°C adjustable	
Temperature Display Accuracy	±0.1°C	
External Temperature Sensor	PT100 (accuracy ±0.6C) (Standard)	
Speed Control Accuracy	±1rpm	
Protection Class	IP21	
Motor Power	20W	
Heating Power	≤400W	
Power Supply	Standard: 220V 50/60Hz, optional: 110V 50/60Hz	
External Size (L*W*H)	222*320*122mm	
Net weight	4.6kg	4.2kg
Packing Size	300*410*210mm	
Gross Weight	6.0kg	5.5kg

Features of BS-2H/3H:

- * Cast Aluminum with surface spraying plate.
- * Max. Temp.: 380°C, max. speed: 2000rpm.
- * Heating and stirring can proceed simultaneously.
- * Heating power and stirring speed is steplessly adjusted.



BS-2H



BS-3H

Features of BS-4H/4HC:

- * Ceramic plate.
- * PT100 sensor is standard for BS-4HC.
- * With the adjustable rack and stirrer bar.
- * Max. Temp.: 380°C, max. speed: 2000rpm.
- * Heating and stirring can proceed simultaneously.
- * Heating power and stirring speed is steplessly adjusted.
- * Enclosed hot plate with flame protection, fast warm-up and durability.



BS-4H



BS-4HC

Technical Parameters:

Model	BS-2H	BS-3H	BS-4H	BS-4HC
Work Plate Size	120*120mm	170*170mm	190*190mm	
Plate Load(kg)	3	10		
Work Plate Material	Cast Aluminum with surface spraying		Ceramic	
Max. Stirring Capacity	2L	5L		
Speed Range	100~2000rpm		200~2000rpm	
Heating Temp	380°C			350 °C
Power Consumption	180W	500W	600W	
Power Supply	AC110/220V±10%, 50/60Hz			
Standard Accessory	Adjustable rack, stirrer bar; PT100 sensor (only for BS-4HC)			
External Size(W*D*H) mm	200*120*90	265*185*190	320*190*125	
Package Size(W*D*H) mm	250*180*120	280*210*220	390*240*230	
Net Weight(kg)	1.9	2.2	5	
Gross Weight(kg)	3	3.4	6	

Hotplate Magnetic Stirrer



MYP11-2



MYP11-2A



SH05-3G



X85-2



X85-2S

Technical Parameters:

Model	MYP11-2	MYP11-2A	SH05-3G	X85-2	X85-2S
Work Plate Size	φ145mm		φ175mm	φ145mm	
Work Plate Material	Aluminum alloy		Stainless steel	Aluminum alloy	
Max. Stirring Capacity	5L		10L	5L	
Motor Type	Brushless DC motor				
Motor Output	15W			10W	
Speed Range	0~1500rpm				
Digital Display	Speed, temperature, time			/	Speed
Control	Button	Knob + Button	Button	Knob	
Heating Output	600W		800W	600W	
Heating Temp. Range	RT~320°C		RT~250°C	50~300°C	
Temp. Accuracy	±0.5°C		±1°C	/	
Timing Range	1~9999min		1~250min	/	
Power Supply	220V, 50Hz				
External Size(W*D*H) mm	280*160*90		330*190*130	250*150*135	
Package Size(W*D*H) mm	380*300*190		430*330*230	360*290*240	
Gross Weight(kg)	4.5		7	6	



MS7-H550-Pro

MS7-H550-S

MS-H-ProA

MS-H-Prot
(with timer)

MS-H-S

MS-H280-Pro

Technical Parameters:

Model	MS7-H550-Pro	MS7-H550-S	MS-H-ProA	MS-H-Prot	MS-H-S	MS-H280-Pro
Item No.	8030122111	8030122211	8060221110	8030201110	8030211010	8030101212
Work Plate Size	184*184mm (7 inch)		φ135mm (5 inch)			
Work Plate Material	Glass ceramic		Aluminum	Stainless steel with ceramic coated		
Max. Stirring Capacity	20L	10L	20L	3L		
Motor Type	Brushless DC motor	Shaded pole motor	Brushless DC motor			
Motor Input	18W	15W	18W	5W		
Motor Output	10W	1.5W	10W	3W		
Speed Range	100~1500rpm	0~1500 rpm	100~1500rpm	0~1500rpm		200~1500rpm
Speed Display	LCD	Scale	LCD	Scale	LED	
Speed Display Accuracy	±1rpm	/	±1rpm	±1rpm		
Heating Output	1000W		600W	500W		
Heating Temp. Range	RT~550°C, increment 1°C	RT~550°C, increment 5°C	RT~340°C, increment 1°C	RT~340°C		RT~280°C, increment 1°C
Control Temp. Accuracy	±1°C(<100°C) ±1%(>100°C)	±10°C	±1°C(<100°C) ±1%(>100°C)	/		
Overheating Protection	580°C		420°C	320°C		
Temp. Display	LCD	LED	LCD	Scale	LED	
Display Temp. Accuracy	±0.1°C	±1°C	±0.1°C	/		
Timing Range	/			1~99h59min	/	
Optional Accessory	PT1000 (accuracy ±0.2°C)			/		PT1000 (accuracy ±0.5°C)
Residual Heat Warning	50°C			/		
Max. Stirrer Bar Length	80mm			50mm		
Interface	RS232	/	RS232	/		
Protection Type	IP21		IP21	IP42		IP21
Working Environment	5~40°C, 80%RH					
Power Consumption	1050W	1030W	650W	550W	530W	515W
Power Supply	AC110/220V±10%, 50/60Hz (Customizable)					
External Size(W*D*H)	215*360*112mm		160*280*100mm	160*280*85mm		150*260*80mm
Package Size(W*D*H)	500*360*270mm		470*260*250mm			310*250*230mm
Gross Weight	7kg		5kg		4kg	

Magnetic Stirrer



Features:

- * Stepless speed regulation, the maximum speed can reach 2600rpm
- * Using DC brush motor, low noise and stable speed regulation
- * The stirrer is made of fluorine material and high-quality magnetic steel. It has the characteristics of high temperature resistance, wear resistance, chemical corrosion resistance and strong rotation force.
- * The mixing work can be carried out in a sealed container, and the use is simple and convenient.
- * Simple and beautiful appearance, exquisite and compact, light weight, does not occupy laboratory space

Technical Parameters:

Model	BK-ST1
Motor Type	DC brushed motor
Maximum Volume	2L
Rotation Range	0-2600rpm stepless speed regulation
Timing Range	0-120min
Working Plate Size	Diameter 125mm
Stirring Power	5W
Power Supply	100-120/200-240V 50-60Hz
Overall Dimensions(mm)	240*180*110
Net Weight(kg)	1.7kg
Packing Size(mm)	330*265*197
Gross Weight(kg)	2.5

Mini Magnetic Stirrer



Features:

- * Mini and compact, light weight, easy to carry, easy to operate
- * Dc brushless motor, low noise for long-term operation
- * High performance strong magnetic mixer, strong magnetic force is not easy to jump
- * The body adopts ABS+PC alloy material, stable and durable, bevel design, better visual effect
- * The machine adopts excellent ergonomic design, the interface is simple and easy to operate
- * The maximum mixing capacity can reach 3L

Technical Parameters:

Model	BJPX-SC11-MN
Disk Material	ABS+PC
Working Surface Size	φ130mm
Motor Type	Brushless DC motor
Stirring Point	1
Maximum Mixing Volume	3L
Maximum Length of Stirrer	40mm
Speed Display	LED display
Set Precision	10rpm
Range of Rotation	200-2000rpm
Timing Function	0-99h59min
Rated Power	5W
Power Supply	AC 100-220V 50/60Hz
Overall Size	140*46*162mm
Net Weight	0.3kg
Packing Size	270*88*215mm
Gross Weight	0.6kg

Magnetic Stirrer



Features:

- * Using brushless DC motor, the maximum speed can reach 2000rpm
- * Strong magnetic force, uniform stirring, the maximum stirring volume can reach 20L
- * Intelligent digital display for easy reading
- * The stirrer is made of fluorine material and high-quality magnetic steel. It has the characteristics of wear resistance, chemical corrosion resistance and strong rotation force.
- * Simple operation (knob type operation), easy to complete the experiment

Technical Parameters:

Model	BK-ST20L
Motor Type	DC brushless motor
Maximum Volume	20L
Rotation Range	50-2000rpm
Working Plate Size	262*200mm
Stirring Power	36W
Power Supply	100-240V 50/60Hz
Overall Dimensions(mm)	285*220*91
Net Weight(kg)	2.65
Packing Size(mm)	360*260*180
Gross Weight(kg)	3.5



MS-S



MS-PA



MS-PB

Technical Parameters:

Model	MS-S	MS-PA	MS-PB
Work Plate Size	φ135mm (5 inch)		
Item No.	8030211000	8030284200	8030294000
Work Plate Material	Stainless steel with ceramic coated	Nylon + GF	
Max. Stirring Capacity	20L	3L	
Motor Type	Brushless DC motor		
Motor Input	18W	5W	
Motor Output	10W	3W	
Speed Range	0~1500rpm		
Speed Display	Scale	LED	Scale
Max. Stirrer Bar Length	80mm	50mm	
Working Environment	5~40°C, 80%RH	10~40°C, 80%RH	
Protection Type	IP42		
Power Consumption	30W	15W	10W
Power Supply	AC110/220V±10%, 50/60Hz (Customizable)		
External Size(W*D*H)	160*280*85mm	150*260*80mm	
Package Size(W*D*H)	480*260*250mm	310*250*230mm	
Gross Weight	4kg	3kg	

Optional Accessories:

		Stirrer bars and bar remover(PTFE), use below 150°C		
		Models MS7-H550-Pro MS-H280-Pro MS-H-S10 MS7-H550-S MS-PA MS-M-S10 MS-H-ProA MS-PB MS-H-Prot MS-H-S MS-S		
Cat. No.	Size of magnetic bars (L*Ø) mm	Suitable for Max. magnetic bar 80mm	Suitable for Max. magnetic bar 50mm	Suitable for Max. magnetic bar 40mm
18900006	10*6	√	√	√
18900007	15*8	√	√	√
18900008	20*8	√	√	√
18900009	25*8	√	√	√
12500005	30*6	√	√	√
18900011	40*8	√	√	√
12500004	50*8	√	√	/
18900013	65*8	√	/	/
18900014	80*13	√	/	/
18900015	Magnetic bar remover, length of 200mm	/	√	/

Cat. No.	18900019	18900016	18900136	18900017	18900540
Descriptions	F101 protective cover, for hotplate models, temperature resistance of 135°C	PT1000-A, temperature sensor for digital hotplate models, length of 230mm	PT1000-B, temperature sensor with glass coated, length of 230mm, used for digital hotplate models	Support clamp of PT1000	Support clamp of PT1000, use with MS-H280-Pro
Model	MS7-H550-Pro	/	√	√	/
MS7-H550-S	/	√	√	√	/
MS-H-ProA	√	√	√	√	/
MS-H-Prot	/	√	√	√	/
MS-H-S	√	/	/	/	/
MS-H280-Pro	/	√	√	/	√

			18101009	Reaction block for 500ml round bottom flask (one flask capacity)								
			18101008	Reaction block for 250ml round bottom flask (one flask capacity)								
			18101007	Reaction block for 100ml round bottom flask (one flask capacity)								
			18101006	Reaction block for 50ml round bottom flask (one flask capacity)								
			18900049	Golden quarter pie, 4 holes, 16ml reaction vessel, Ø21.6mm, 31.7mm depth								
			18900048	Green quarter pie, 6 holes, 8ml reaction vessel, Ø17.8mm, 26mm depth								
			18900005	Black quarter pie, 4 holes, 40ml reaction vessel, Ø28mm, 43mm depth								
			18900004	Blue quarter pie, 4 holes, 30ml reaction vessel, Ø28mm, 30mm depth								
			18900003	Purple quarter pie, 4 holes, 20 ml reaction vessel, Ø28mm, 24mm depth								
			18900002	Red quarter pie, 11 holes, 4 ml reaction vessel, Ø15.2mm, 20mm depth								
			18900065	Blue Fixed ring, use with color quarter pies								
			18900001	Blue carrying plate, use with color quarter pies								
Cat. No.	18900001	18900065	18900002	18900003	18900004	18900005	18900048	18900049	18101006	18101007	18101008	18101009
Descriptions	Blue carrying plate, use with color quarter pies	Blue Fixed ring, use with color quarter pies	Red quarter pie, 11 holes, 4 ml reaction vessel, Ø15.2mm, 20mm depth	Purple quarter pie, 4 holes, 20 ml reaction vessel, Ø28mm, 24mm depth	Blue quarter pie, 4 holes, 30ml reaction vessel, Ø28mm, 30mm depth	Black quarter pie, 4 holes, 40ml reaction vessel, Ø28mm, 43mm depth	Green quarter pie, 6 holes, 8ml reaction vessel, Ø17.8mm, 26mm depth	Golden quarter pie, 4 holes, 16ml reaction vessel, Ø21.6mm, 31.7mm depth	Reaction block for 50ml round bottom flask (one flask capacity)	Reaction block for 100ml round bottom flask (one flask capacity)	Reaction block for 250ml round bottom flask (one flask capacity)	Reaction block for 500ml round bottom flask (one flask capacity)
Magnetic hotplate stirrers are available to hold quarter color pies(volume range from 4mL to 16mL) and reaction blocks (volume range from 50mL to 2000mL), which ensure uniform heating distribution and excellent resistance to chemicals. The color pies and blocks with aluminum material which are easy to clean and safety for lab.												
Model	MS7-H550-Pro	/	√	√	√	√	√	√	/	/	/	/
MS7-H550-S	/	/	√	√	√	√	√	√	/	/	/	/
MS-H-ProA	√	√	√	√	√	√	√	√	√	√	√	√
MS-H-Prot	/	/	√	√	√	√	√	√	√	√	√	√
MS-H-S	/	/	√	√	√	√	√	√	√	√	√	√
MS-H280-Pro	/	/	√	√	√	√	√	√	√	√	√	√

Magnetic Stirrer



Technical Parameters:

Model	98-2	H03-A	85-1	85-2A	90-1	90-1B	96-1	H01-2
Work Plate Material	Stainless steel							
Max. Stirring Capacity	10L		3L	5L	20L		50L	
Motor Type	Brushless DC motor							
Speed Range	0~2000rpm		0~1500rpm	0~2000rpm	0~2000rpm	0~1400rpm		
Digital Display	/	Speed	/	/	/	Speed	/	Speed
Control	Knob							
Motor Power	15W		8W	10W	40W	100W		
Power Supply	220V, 50Hz							
External Size(W*D*H)mm	260*160*85	210*210*85	210*130*65	245*145*100	305*300*105	410*400*115		
Package Size(W*D*H)mm	450*300*250	400*400*250	400*260*215	380*300*220	510*430*250	550*550*220		
Gross Weight(kg)	8	7.5	5.5	7.5	10	20		

Multi-Position Magnetic Stirrer



Technical Parameters:

Model	MS-M-S10 (8030140013)	MS-H-S10 (8030140000)	84-1 (4 positions)	84-1 (6 positions)	524G	H01-1D
Work Plate Size	180*450mm		290*280mm	420*300mm	φ145mm	
Work Plate Material	Stainless steel with silicone film		Stainless steel		Aluminum alloy	Stainless steel
Max. Stirring Capacity	0.4L*10	0.4L*10	1.5L*4	1.5L*6	3L*4	3L*6
Motor Type	Brushless DC motor					
Speed Range	0~1100rpm		0~1500rpm		0~1400rpm	0~1500rpm
Digital Display	/		Speed		Speed, Temperature, Time	
Control	Scale		Knob		Button	Knob
Heating Output	/		470W		4*600W	6*360W
Heating Temp. Range	/		RT~120°C		RT~150°C	
Working Environment	5~40°C, 80%RH					
Power Supply	AC110/220V±10%, 50/60Hz		220V, 50Hz			
External Size(W*D*H)	210*630*65mm		290*280*80mm	420*300*80mm	380*380*145mm	1005*230*130mm
Package Size(W*D*H)	700*420*270mm		540*350*180mm	670*380*180mm	520*520*240mm	1130*400*270mm
Gross Weight	7.5kg		8kg	12kg	15kg	35kg

Magnetic Stirring Water Bath



Features:

- * High-quality cold-rolled steel plate outer shell, the surface is sprayed with environmental protection spray processing, good corrosion resistance.
- * Good performance, no noise, no vibration, fast heating
- * Artistic and reasonable, easy to maintain
- * LED display, real-time temperature display

Technical Parameters:

Model	MSW-101S
Display	LED
Power	600W
Heating Temp. Range	R.T.~100°C
Stirring Power	2.5W
Stirring Capacity	50~2000ml
Work Plate Size	Φ200*100
Speed Range	0~2600rpm
Power Supply	220V, 50Hz
External Size	340*340*290mm
Package Size	390*390*360mm
Net Weight	6.4kg
Gross Weight	10kg

Note:

1. Please use a three-phase safety socket and properly grounded.
2. The instrument should be kept clean, it should be cut off the power supply when long-term not using.
3. Do not open the temperature control switch when the stainless steel container is not added with thermal oil and the temperature sensor is not connected, so as to avoid damage to the heating element and constant temperature meter.

Overhead Stirrer



Features:

- * Color LCD with backlight displays speed and time in real time, with 5 sets of speed memory functions, convenient for accurate reading and easy operation.
- * Accurately control the speed with a control accuracy of $\pm 3\text{RPM}$; accurately display the true value/set value of the speed
- * Constant rotation speed, automatic adjustment of torque according to changes in sample viscosity
- * Prevent sample overflow, start smoothly, effectively prevent sample overflow
- * The closed shell prevents liquid from splashing into the machine and corroding the circuit, allowing it to run continuously and stably for a long time.

Technical Parameters:

Model	BJPX-OHS20
Maximum Volume	20L
Rotation Range	50-3000rpm
Speed Control Accuracy	$\pm 3\text{rpm}$
Timing Range	30s-999min
Speed/time Display	LCD
Motor Type	Brushless DC motor
Stirring Maximum Viscosity	10000mPas
Power Supply	AC100-240V 50/60Hz
Power	60W
Overall Dimensions(mm)	160*230*600
Net Weight(kg)	5.2
Packing Size(mm)	450*345*155
Gross Weight(kg)	6.2

Overhead Stirrer















OS40-S/OS20-S LED Overhead Stirrer OS40-S/OS20-S with universal plate stand OS40-Pro/OS20-Pro LCD Overhead Stirrer OS40-Pro/OS20-Pro with universal plate stand

Technical Parameters:

Model	OS40-S	OS20-S	OS40-Pro	OS20-Pro
Item No.	8033200200	8033100200	8033200100	8033100100
Max. Stirring Capacity	40L	20L	40L	20L
Motor Input	120W	60W	120W	60W
Motor Output	100W	50W	100W	50W
Speed Range	50~2200rpm			
Speed Control Accuracy	/		±3rpm	
Speed Display	LED		LCD	
Max. Torque	60N•cm	40N•cm	60N•cm	40N•cm
Torque Display	/		LCD	
Overload Protection	Visual alarm, motor automatic stop			
Overload protection display	/	/	LCD	
Max. Viscosity	50000mPa·s	10000mPa·s	50000mPa·s	10000mPa·s
Chuck Diameter Range	0.5~10mm			
Protection Type	IP21			
Working Environment	5~40°C, 80%RH			
Interface	/		RS232	
Power Consumption	130W	70W	130W	70W
Power Supply	AC110/220V±10%, 50/60Hz (Customizable)			
Standard Accessory	Propeller stirrer 18900071		Universal plate stand 18900605, Propeller stirrer 18900071	
External Size(W*D*H)	83*186*220mm			
Package Size(W*D*H)	Main body & Stirrer: 480*380*450mm		Main body & Stirrer: 480*380*450mm	
	480*380*450mm		Universal plate stand: 800*360*130mm	
Gross Weight	Main body & Stirrer: 6kg		Main body & Stirrer: 6kg	
			Universal plate stand: 8kg	

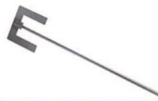
Optional Accessories:

				
Cat. No.	18900605	18900071	18900072	
Descriptions	Universal plate stand (W*D: 20*31cm), including support holder (H: 78cm) and fixing device	Propeller stirrer, shaft length 40cm, stirrer diameter 5cm, 316L stainless steel Standard stirring element, used at medium and high speeds	Straight stirrer, shaft length 40cm, stirrer diameter 6cm, 316L stainless steel Suitable for mixing of low viscosity media, used at medium and high speeds	
				
Cat. No.	18900073	18900074	18900075	
Descriptions	Paddle stirrer, shaft length 40cm, stirrer diameter 6.8cm, 316L stainless steel Gentle processing samples, used at low and medium speeds	Centrifugal stirrer, shaft length 40cm, stirrer diameter 9cm, 316L stainless steel Blades open with increasing speed for stirring in a round vessel with a narrow neck, used at medium and high speeds	Propeller stirrer, shaft length 35cm, stirrer diameter 6.5cm, PTFE coated Standard stirring element, used at medium and high speeds	
				
Cat. No.	18900076	18900077	18900078	
Descriptions	Straight stirrer, shaft length 35cm, stirrer diameter 7cm, PTFE coated Suitable for mixing of low viscosity media, used at medium and high speeds	Paddle stirrer, shaft length 35cm, stirrer diameter 6.8cm, PTFE coated Gentle processing samples, used at low and medium speeds	Centrifugal stirrer, shaft length 35cm, stirrer diameter 8.5cm, PTFE coated Blades open with increasing speed for stirring in a round vessel with a narrow neck, used at medium and high speeds	
				
Cat. No.	18900478	18900498	18900499	18900500
Descriptions	Crossed stirrer, shaft length 60cm, stirrer diameter 10cm, 316L stainless steel	Straight stirrer, shaft length 60cm, stirrer diameter 10cm, 316L stainless steel	Blade stirrer, shaft length 60cm, stirrer diameter 10cm, 316L stainless steel	Centrifugal stirrer, shaft length 60cm, stirrer diameter 10cm, 316L stainless steel

Hot Plate

Graphite Hot Plate

Features:

- * Real-time temperature value display, countdown display.
- * PID microprocessor controls temperature.
- * Built-in temperature deviation calibration function.
- * LCD liquid crystal display.
- * The timer can precisely control the heating time, the timing range: 0 to 9999 minutes (hours); the timing error: < 1%.
- * Using a new heating method, the heating body is made of isostatically pressed high-purity graphite with excellent thermal conductivity, which has excellent corrosion resistance.
- * The temperature rises quickly and evenly, and the operation is simple and safe to use.



Technical Parameters:

Model	BJPX-HPG3040
Working Size	400*300mm
Temp. Control Range	RT~350°C
Temp. Control Precision	±0.1°C
Stage Material	Graphite with stainless steel on the edge
Power	2000W
Power Supply	220V/110V, 50/60Hz
External Size	447*305*225mm
Net Weight	16kg
Packing Size	685*385*345mm
Gross Weight	19kg

Electric hotplate

Features:

- * Real-time temperature value display, countdown display.
- * PID microprocessor controls temperature.
- * Built-in temperature deviation calibration function.
- * LCD liquid crystal display
- * The timer can precisely control the heating time, the timing range: 0 to 9999 minutes (hours); the timing error: < 1%.
- * Using a new heating method, the heating body is made of isostatically pressed high-purity graphite with excellent thermal conductivity, which has excellent corrosion resistance
- * The temperature rises quickly and evenly, and the operation is simple and safe to use.



Technical Parameters:

Model	BJPX-HP3040
Working Size	400*300mm
Temp. Control Range	RT~320°C
Temp. Control Precision	±1°C
Stage Material	304 Stainless Steel
Power	2000W
Power Supply	220V/110V, 50/60Hz
External Size	450*215*305mm
Net Weight	15kg
Packing Size	480*245*360mm
Gross Weight	18kg

Ceramic Hot Plate



Features:

- * PID controller
- * Totally enclosed ceramic heating plate, with halogen-light, heating up fast, safe and reliable.

Technical Parameters:

Model	CH-300	CH-400
Plate Size	300*200mm	400*280mm
Max. Temperature	450°C	
Material(Main body)	Cold-rolled steel with anti-bacteria powder coating	
Work Plate Material	Ceramic	
Power Supply	AC220V,50/60Hz	
Consumption	1800W	2200W
External Size(W*D*H)mm	350*340*188	450*420*188
Package Size(W*D*H)mm	490*445*310	590*525*315
Gross Weight(kg)	18	19

Graphite Hot Plate



Features:

- * PID controller
- * Totally enclosed high purity graphite, keeps temperature uniformity
- * Double shell design, with anti-corrosion power coating, keeps the normal work of the instrument in acid environment.

Technical Parameters:

Model	GH-300	GH-400	GH-450	GH-600
Plate Size	300*200mm	400*280mm	450*350mm	600*400mm
Range of Temperature	RT+10 ~ 450°C			
Temperature Control Accuracy	±0.1°C			
Material(Hot plate)	Graphite with anti-bacteria powder coating			
Temp. Fluctuation Degree	±1.0°C			
Power Supply	AC220V,50/60HZ			
Consumption	1000W	1500W	2000W	3000W
External Size(W*D*H)mm	300*275*210	400*355*230	450*425*230	600*475*230
Package Size(W*D*H)mm	350*330*260	520*450*345	570*520*345	740*580*345
Gross Weight(kg)	10	15	17	28

Glass Ceramic Hot Plate



Features:

- * LED display.
- * Totally enclosed glass ceramic heating plate, provides chemical-resistant and most efficient heat transfer.
- * Separate safety circuits with fixed safety temperature of 580°C.
- * External temperature control is possible by connecting the temperature sensor (PT 1000) with an accuracy of $\pm 0.5^{\circ}\text{C}$.
- * Alarm: The HOT warning will flash when the heating plate temperature is over 50°C, even the heating plate is turned off.

Technical Parameters:

Model	HP550-S
Item No.	5031122211
Plate Size	184*184mm (7 inch)
Heating Temperature Range	Room temp.-550°C, increment 5°C
Heating Accuracy	$\pm 10^{\circ}\text{C}$
Heating Position	1
Material(Main body)	Glass ceramic
Protection Warning	50°C
Protection Type	IP21
Power Supply	AC110/220V $\pm 10\%$; 50/60Hz (Customizable)
Power	1010W
Heating Power	1000W
Working Environment	5-40°C, 80%RH
External Size(W*D*H)	215*360*112mm
Package Size(W*D*H)	500*360*270mm
Gross Weight	7kg

Aluminum/Ceramic Hot Plate



AH-120E



AH-170E



CH-190E



AH-400/600D



AH-400/600E

Features:

- * LED display (AH-400D/AH-600D)
- * Heating can proceed simultaneously
- * Enclosed hot plate with flame protection, fast warm-up and durability

Technical Parameters:

Model	AH-120E	AH-170E	CH-190E	AH-400E/D	AH-600E/D
Plate Size	120*120mm	170*170mm	190*190mm	400*400mm	400*600mm
Max. Temperature	RT~380°C			RT~350°C	
Work Plate Material	Aluminum		Ceramic	Aluminum	
Power Supply	AC110/220V $\pm 10\%$, 50/60Hz			AC220V $\pm 10\%$, 50/60Hz	
Consumption	180W	500W	600W	2000W	3000W
External Size(W*D*H)mm	200*120*90	265*185*190	320*190*125	400*400*180	400*600*180
Package Size(W*D*H)mm	250*180*190	280*210*220	390*240*230	450*470*220	470*650*220
Gross Weight(kg)	3	3.4	6	9.8	14.2

Electronic & Digital Hot Plate

Application:

It applies in drying articles in chemical analysis, physical determination, heat treatment and other temperature experiments in laboratories of industrial mining enterprise, medicine and health, environmental protection, biochemistry and scientific research and college labs etc.



Electronic Hot Plate(SSH-E Series)



Digital Hot Plate (SSH-D Series)

Features:

- * PID controller
- * Totally enclosed high quality stamping cold-rolled steel heating plate, with no open fire.
- * SSH-E type, adopts electric temperature control, could adjust temperature.
- SSH-D type, with LED display, easy to observe and control temperature.
- * Control style: SSH-E electric type SSH-D digital type.

Technical Parameters: Model	SSH-E400	SSH-E450	SSH-E600	SSH-D400	SSH-D450	SSH-D600
Plate Size	400*280mm	450*350mm	600*400mm	400*280mm	450*350mm	600*400mm
Range of Temperature	RT+20~380°C					
Material (Main body)	Cold-rolled steel with anti-bacteria powder coating					
Work Plate Material	Stainless steel					
Power Supply	AC220V,50/60HZ					
Consumption	1500W	2000W	3000W	1500W	2000W	3000W
Package Size(W*D*H)mm	450*340*290	500*400*290	650*460*290	450*340*290	500*400*290	650*460*290
Gross Weight(kg)	16	22	30	16.5	21.5	30

Heating Mantle

Several Rows Electronic Control Heating Mantles



HMD-III(LED Display)



HME-III

Features:

- * Corrosion-resisting and ageing-resistent
- * The internal heater is in hemisphere shape with high efficiency.
- * The external material is cold-rolled steel with anti-bacteria powder coating.
- * It adopts high-temperature resistant alkali-free glass fiber with good isolation performance.

Technical Parameters:

Model	Rows	Capacity (ml)	Max. Use Temp.	Working Time	Consumption(W)	Power Supply	External Size (W*D*H) mm	Packing Size (W*D*H) mm	Net Weight	Gross Weight
HME-III	Two rows	100	380°C	Continuous	200	AC110/ 220V± 10%, 50/60Hz	280*290*150	375*385*245	4kg	7kg
		250			360		280*290*150	375*385*245	4kg	7kg
		500			500		320*320*155	415*415*245	5kg	8kg
		1000			600		390*355*150	485*450*245	7kg	10kg
HMD-III (LED Display)	Four rows	100			400		550*290*150	645*385*245	8kg	11kg
		250			720		550*290*150	645*385*245	8kg	11kg
		500			1000		635*315*150	730*410*245	10kg	13kg
		1000			1200		780*350*150	875*445*245	14kg	17kg
	Six rows	100			600		830*295*150	925*390*245	12kg	17kg
		250			1080		830*295*150	975*440*245	13kg	18kg
		500			1500		950*310*150	1045*405*245	14kg	19kg
		1000			1800		1170*355*150	1670*450*245	20kg	23kg

Electronic & Digital Heating Mantles



HMD-I



HME-I

Features:

- * Corrosion-resisting and ageing-resistant.
- * The internal heater is in hemisphere shape with high efficiency.
- * The external material is cold-rolled steel with anti-bacteria powder coating.
- * It adopts high-temperature resistant alkali-free glass fiber with good isolation performance.

Technical Parameters:

Model	HME-I / HMD-I(LED Display)									
Capacity(ml)	100	250	500	1000	2000	3000	5000	10000	20000	50000
Max. Temp.	380°C									
Working Time	Continuous									
Consumption	100W	180W	250W	300W	500W	600W	1000W	1500W	2500W	6000W
Power Supply	AC220/110V±10%, 50/60Hz									
Internal Size (mm)	Φ70*40	Φ95*50	Φ150*50	Φ150*70	Φ180*80	Φ200*100	Φ245*150	Φ310*175	Φ380*190	Φ480*270
External Size (W*D*H)	220*195*165mm			280*260	320*300	355*300	415*370	480*430	540*530	665*450
				*205mm	*215mm	*240mm	*270mm	*300mm	*280mm	*550mm
Packing Size (W*D*H)	265*270*240mm			320*320	360*355	360*360	420*420	470*470	540*540	775*775
				*260mm	*290mm	*330mm	*255mm	*330mm	*440mm	*560mm
Net Weight	1.7kg	1.8kg	1.8kg	2.55kg	3.8kg	4.2kg	7kg	10.2kg	13.3kg	53kg
Gross Weight	2.5kg			3.7kg	5kg	5.7kg	10kg	11.5kg	17kg	68kg

Electronic & Digital Magnetic Stirring Heating Mantles



HMD-II



HME-II

Features:

- * The internal heater is in hemisphere shape with high efficiency.
- * The external material is cold-rolled steel with anti-bacteria powder coating.
- * Stepless speed adjustment, uniform temperature, easy to operate with effective use.
- * It adopts high-temperature resistant alkali-free glass fiber with good isolation performance.
- * Stable precise stirring to liquid solution is within a wider speed scope, especially in the experiments of samples with small volume.

Technical Parameters:

Model	HME-II / HMD-II(LED Display)				
Capacity(ml)	100	250	500	1000	2000
Max Use Temp.	380°C				
Speed	0~1200rpm				
Working Time	Continuous				
Max Use Temp.	380°C				
Consumption	100W	180W	250W	300W	500W
Power Supply	AC220/110V±10%, 50/60Hz				
Internal Size(mm)	Φ70*50	Φ90*60	Φ105*65	Φ135*80	Φ175*95
External Size(W*D*H)	220*195*165mm	220*195*165mm	220*195*165mm	280*260*205mm	320*300*215mm
Packing Size(W*D*H)	295*290*255mm	290*285*250mm	295*290*255mm	350*345*305mm	385*380*340mm
Net Weight	3kg	3kg	4kg	4kg	5kg
Gross Weight	4kg	4kg	5kg	6kg	7kg

Electronic & Digital Heating Mantles



Features:

- * Electronic temperature regulation, stepless regulation.
- * Cold rolled steel plate, surface sprayed.
- * Thermal insulation cotton is high quality aluminum silicate cotton.
- * PID single digital temperature controller, can automatically control the temperature, digital display, fast heating, uniform temperature, accurate temperature control. (only for HMD-IIC)
- * PT100 temperature sensor, equipped with adjustable sensor bracket. (only for HMD-IIC)

Technical Parameters:

Model	HME-IB / HMD-IIC(LED display)									
Capacity(ml)	50	100	250	500	1000	2000	3000	5000	10000	20000
Max. Temp	450°C									
Working Time	Continuous									
Heating Power(kW)	0.08	0.1	0.15	0.25	0.35	0.45	0.6	0.8	1.2	2.5
Power Supply	Standard: 200~240V, 50/60Hz Optional: 110V, 50/60Hz									
External Size(mm)	Φ200*165		Φ280*220	Φ330*230	Φ340*245	Φ350*250	Φ425*320	Φ470*340		
Package Size(mm)	230*230*195		290*290*300	340*340*350	360*360*300	390*390*310	430*430*350	510*510*380		
Net Weight(kg)	2.5		5.5	6.5	7.5	8	9.8	16		
Gross Weight(kg)	2.8		6	7	8	9.2	12	20		

Electronic & Digital Magnetic Stirring Heating Mantles



Features:

- * Electronic temperature regulation, stepless regulation.
- * Cold rolled steel plate, surface sprayed.
- * Thermal insulation cotton is high quality aluminum silicate cotton.
- * PID single digital temperature controller. (only for HMD-IIIB)
- * PT100 temperature sensor, equipped with adjustable sensor bracket. (only for HMD-IIIB)

Technical Parameters:

Model	HME-IIB / HMD-IIIB(LED display)									
Capacity(ml)	50	100	250	500	1000	2000	3000	5000	10000	20000
Max. Temp	450°C									
Temp Control	RT+20~250°C									
Speed	0~1600rpm									
Working Time	Continuous									
Motor Power(kW)	0.01									
Heating Power(kW)	0.08	0.1	0.15	0.25	0.35	0.45	0.6	0.8	1.2	2.5
Power Supply	Standard: 200~240V, 50/60Hz Optional: 110V, 50/60Hz									
External Size(mm)	Φ200*165		Φ280*220	Φ330*230	Φ340*245	Φ350*250	Φ425*320	Φ470*340		
Package Size(mm)	230*230*195		290*290*300	340*340*350	360*360*300	390*390*310	430*430*350	510*510*380		
Net Weight(kg)	2.5		5.5	6.5	7.5	8	9.8	16		
Gross Weight(kg)	2.8		6	7	8	9.2	12	20		

PH Meter

Pocket pH /°C/°F Tester

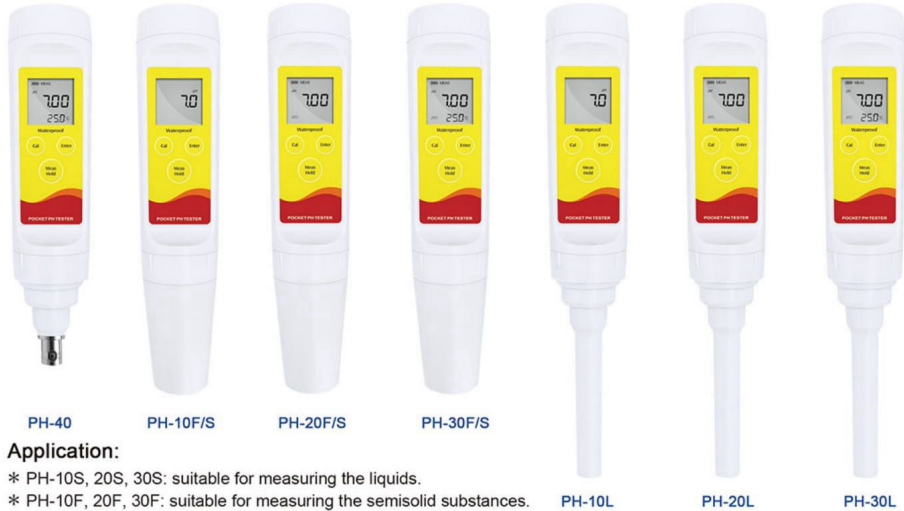

Application:

- * PH-10S, 20S, 30S: suitable for measuring the liquids.
- * PH-10F, 20F, 30F: suitable for measuring the semisolid substances.
- * PH-10L, 20L, 30L: suitable for measuring the small volume samples.
- * PH-40 is suitable for connecting with the various pH electrodes.

PH-10/20 Features:

- * 2 points push-button calibration with auto-buffer recognition.
- * Hold function freezes current measured value for easy viewing and recording.
- * Auto-Power Off helps user effectively conserve battery life.
- * Replaceable electrode module reduces maintenance and replacement cost.



PH-30/40 Features:

- * BNC connector is easy to connect a variety of pH electrodes (Only for PH-40).
- * 1 to 3 points calibration with automatic recognition for USA and NIST buffers.
- * Automatic temperature compensation ensures accurate readings over the entire range (Only for PH-30); Manual temperature compensation provides a wide range of temperature input (Only for PH-40).
- * Auto-Read function senses and locks the measurement endpoint
- * Setup menu allows setting the pH buffer set, number of calibration points, temperature unit, auto-power off, etc.
- * Reset function automatically resumes all settings back to the factory defaults.



Replaceable pH Electrodes:



PH-S

Circular pH-sensitive membrane
Suitable for measuring the liquids



PH-F

Flat surface pH-sensitive membrane
Suitable for measuring the semisolids



PH-L

Flat surface pH-sensitive membrane
Suitable for measuring the small volume samples

Accessories:

pH buffer pouches (pH4.01/7.00/10.01), batteries, plastic box or carrying case.

Technical Parameters:

Model	PH-10S/F/L	PH-20S/F/L	PH-30S/F/L	PH-40	
pH	Range	0.0~14.0pH		-1.00~15.00pH	
	Accuracy	±0.1pH	±0.05pH	±0.01pH	
	Calibration Points	2 points		1~3 points	
	pH Buffer Options	USA (pH4.01/7.00/10.01)		USA (pH4.01/6.86/7.00/9.18/10.01)	
Temperature	Range	/	0~60°C	0~60°C/32~140°F	
	Resolution	/	1°C	0.1°C/0.1°F	
	Accuracy	/	±1°C	±1°C/±1.8°F	
	Offset Calibration	/	/	1 point, reading ±10°C	
Other Specifications	Temp. Compensation	/	0~60°C, Automatic		
	Hold Function	Manual		Manual or Auto-endpoint	
	Auto-Off	8 minutes after last key pressed			
	Operating Temperature	0~50°C			
	Display	Single-line LCD (21*21mm)		Dual-line LCD (21*21mm)	
	Connector	6-pin			BNC
	Power Requirements	3*1.5V LR44 micro alkaline batteries		2*1.5V AAA batteries	
	Battery Life	Approximately 150 hours of continuous use		Approximately 200 hours of continuous use	
	Dimensions (L*D) mm	185 (L) *40 (Dia.)			175 (L)*40 (Dia.)
	Package Size (W*D*H) mm	325*140*270			
Net Weight(g)	100g				
Gross Weight(kg)	1kg				

Portable pH/ORP Meter



Measurement Parameters:

PH-220: pH, mV, temperature

PH-221: pH, mV, relative mV, temperature

PH-220 Features:

- * 1 to 3 points calibration with automatic recognition for USA and NIST buffers.
- * Automatic electrode diagnosis helps user decide whether to replace the pH electrode.
- * Automatic temperature compensation ensures accurate readings over the entire range.
- * Auto-Read function senses and locks the measurement endpoint.
- * Setup menu allows setting the pH buffer set, number of calibration points, temperature unit, auto-power off, etc.
- * Reset function automatically resumes all settings back to the factory defaults.
- * Expanded memory stores or recalls up to 100 data sets.
- * USB communication interface for data transfer or connecting a power adapter to meter.

PH-221 Features:

pH

- * 1 to 5 points calibration with automatic recognition for USA, NIST and DIN buffers.
- * Automatic electrode diagnosis shows the pH slope and offset.
- * Automatic temperature compensation ensures accurate readings over the entire range.
- * Calibration due alarm prompts user to calibrate the meter regularly.

ORP

- * 1 point offset calibration allows adjusting the displayed value to a known standard
- * Relative and absolute millivolt modes ensure the reliable ORP measurements

General Features

- * Auto-Read function senses and locks the measurement endpoint
- * Auto-Power Off effectively conserves battery life
- * Setup menu allows setting the pH buffer set, number of calibration points, resolution, stability criteria, temperature unit, date and time, etc.
- * Reset function automatically resumes all settings back to the factory defaults
- * Expanded memory stores or recalls up to 500 data sets
- * USB communication interface is easy to transfer data to PC
- * Multi-mode power scheme (batteries, power adapter and USB port) ensures that using the meter smoothly

Accessories:

- * PH electrode
- * Temperature probe
- * PH buffer solutions (pH4.01/7.00/10.01)
- * Carrying case



Technical Parameters:

Model	PH-220	PH-221	
pH	pH Range	-2.00~20.00pH	-2.000~20.000pH
	pH Accuracy	±0.01pH	±0.002pH
	Resolution	0.01pH	0.1, 0.01, 0.001pH, Selectable
	Calibration Points	1 to 3 points	1 to 5 points
	pH Buffer Options	USA (4.01/7.00/10.01), NIST (4.01/6.86/9.18)	USA (pH1.68/4.01/7.00/10.01/12.45), NIST (pH1.68/4.01/6.86/9.18/12.45), DIN (pH1.09/4.65/6.79/9.23/12.75) or 2 custom buffers
ORP	mV Range	-1999~1999mV	-1999.9~1999.9mV
	mV Accuracy	±1mV	±0.2mV
	Resolution	1mV	0.1, 1mV, Selectable
	Calibration Points	/	1 point
Temperature	Temperature Range	0~105°C/32~221°F	
	Temperature Accuracy	±0.5°C/±0.9°F	
	Resolution	0.1°C/0.1°F	
	Offset Calibration	1 point, reading ±10°C	
Other Specifications	Temperature Compensation	0~100°C, manual or automatic	
	Stability Criteria	/	Low or high
	Calibration Due Alarm	/	1 to 31 days or off
	Slope/Offset Display	Yes	
	Hold Function	Manual or auto-endpoint	
	Auto-Off	30 minutes after last key pressed	10, 20 or 30 minutes after last key pressed
	Memory	100 data sets	500 data sets
	Communication Interface	USB	
	Connector	BNC, 3.5 mm jack socket	
	Display	Custom LCD (80 × 60 mm)	
	Power Requirements	3*1.5V AA batteries or DC5V power adapter	
Battery Life	Approximately 150 hours (Turn off the backlight)		
Dimensions(W*D*H)	170*85*30mm		
Package Size(W*D*H)	475*155*350mm		
Net Weight	300g		
Gross weight	2kg		

Portable pH/Ion Meter



Measurement Parameters:

PH-320: pH, mV, relative mV, ion concentration, temperature

PH-321: Ion concentration, mV, temperature

Features:

pH

- * 1 to 5 points calibration with automatic recognition for USA, NIST and DIN buffers.
- * Automatic electrode diagnosis shows the pH slope and offset.

ORP

- * 1 point offset calibration allows adjusting the displayed value to a known standard.
- * Relative and absolute millivolt modes ensure the reliable ORP measurements.

Ion Concentration

- * 2 to 5 points calibration, including the 8 concentration points can be selected.
- * Direct ion concentration readout simplifies the measurement process.
- * Automatic electrode diagnosis shows the calibration points and slopes.
- * Selectable concentration units (ppm, mg/L, mol/L, mmol/L) and ionic valency.

General Features:

- * Automatic temperature compensation ensures accurate readings over the entire range.
- * Auto-Read function senses and locks the measurement endpoint.
- * Calibration due alarm prompts user to calibrate the meter regularly.
- * Auto-Power Off effectively conserves battery life.
- * Setup menu allows setting the number of calibration points, resolution, stability criteria, temperature unit, date and time, etc.
- * Reset function automatically resumes all settings back to the factory defaults.
- * Expanded memory stores or recalls up to 500 data sets.
- * USB communication interface is easy to transfer data to PC.
- * Multi-mode power scheme (batteries, power adapter and USB port) ensures that using the meter smoothly.

Optional Ion Selective Electrodes:

Ammonium (NH₄⁺), bromide (Br⁻), cadmium (Cd²⁺), calcium (Ca²⁺), chloride (Cl⁻), cupric (Cu²⁺), cyanide (CN⁻), fluoride (F⁻), iodide (I⁻), lead (Pb²⁺), nitrate (NO₃⁻), potassium (K⁺), silver (Ag⁺), sodium (Na⁺), sulphide (S²⁻) and ammonia (NH₃)

Accessories:

- * PH electrode
- * Temperature probe
- * PH buffer solutions (pH4.01/7.00/10.01)
- * Carrying case



Technical Parameters:

Model	PH-320	PH-321	
pH	pH Range	-2.000~20.000pH	/
	pH Accuracy	±0.002pH	/
	Resolution	0.1, 0.01, 0.001pH, Selectable	/
	Calibration Points	1~5 points	/
	pH Buffer Options	USA (pH1.68/4.01/7.00/10.01/12.45), NIST (pH1.68/4.01/6.86/9.18/12.45), DIN (pH1.09/4.65/6.79/9.23/12.75) or 2 custom buffers	/
ORP	mV Range	-1999.9~1999.9mV	
	Relative mV Range	-1999.9~1999.9mV	/
	mV Accuracy	±0.2mV	
	Resolution	0.1, 1mV, Selectable	
	Calibration Points	1 point (Only for Relative mV mode)	/
Ion	Ion Concentration Range	0.001~19999ppm, mg/L, mol/L (Refer to the range of ISE)	
	Ion Concentration Accuracy	±0.5% F.S (Monovalent), ±1% F.S (Divalent)	
	Calibration Points	2~5 points	
	Calibration Solutions	0.001, 0.01, 0.1, 1, 10, 100, 1000, 10000(ppm, mg/L, mol/L)	
Temperature	Temperature Range	0~105°C/32~221°F	
	Temperature Accuracy	±0.5°C/±0.9°F	
	Resolution	0.1°C/0.1°F	
	Offset Calibration	1 point, reading ±10°C	
Other Specifications	Temperature Compensation	0~100°C, manual or automatic	
	Stability Criteria	Low or high	
	Calibration Due Alarm	1 to 31 days or off	
	Slope/Offset Display	Yes	
	Hold Function	Manual or auto-endpoint	
	Auto-Off	10, 20 or 30 minutes after last key pressed	
	Memory	500 data sets	
	Communication Interface	USB	
	Connector	BNC, 3.5 mm jack socket	
	Display	Custom LCD (80*60 mm)	
	Power Requirements	3*1.5V AA batteries or DC5V power adapter	
	Battery Life	Approximately 150 hours (Turn off the backlight)	
Dimensions(W*D*H)	170*85*30mm		
Package Size(W*D*H)	475*155*350mm		
Net Weight	300g		
Gross weight	2kg		

Laboratory pH Meter



Introduction:

Suitable for environmental monitoring, ecological research, sewage treatment, industrial and mining enterprises, agriculture, medicine, teaching and so on for sampling and determination of pH value of aqueous solution and measuring electrode potential (mV value).

Features:

- * High precision measurement, 0.01 pH accuracy class, high reproducibility of measurement results.
- * With parameter memory function, power on again to display the last set parameters, saving operation steps.
- * With data storage function, up to 1000 sets of storage.
- * Multifunctional electrode holder with multi-hole design, supporting simultaneous use of multiple electrodes, and featuring 360-degree rotation and vertical movement.
- * Equipped with remote upgrade capabilities, customers can perform on-site upgrades according to their needs with ease of operation.
- * The instrument is plugged in for use and comes standard with a Type-C port.

Accessories:

- * pH composite electrode
- * Electrode holder
- * Buffer agent
- * Power adapter

Technical Parameters:

Model	BK-PH3C	BK-PH3E	
Accuracy Class	0.01 pH accuracy class		
Calibration	1 to 3 point calibration		
Display	7-inch touch screen	7-inch integrated glass plate capacitive touch screen	
Temperature Compensation	Manual temperature compensation	Automatic/manual temperature compensation	
pH	Range	-2.00~18.00pH	
	Resolution	0.01pH	
	Reading Error	±0.01pH	
	Repeatability Error	0.005pH	
	Reading Error (Including electrode)	±0.02pH	
	Repeatability Error (Including electrode)	0.01pH	
mV	Range	-1999~1999mV	
	Resolution	1mV	
	Repeatability Error	1mV	
Temperature	Range	/	-5.0~110.0°C
	Resolution	/	0.1°C
	Reading Error	/	±0.2°C
	Reading Error (Including electrode)	/	±0.4°C (0~60°C) ±1.0°C (Other ranges)
Connector	BNC, 3.5mm jack socket		
Power Requirements	DC9V/400mA power adaptor		
Power Supply	AC 110~240V, 50/60Hz		
External Size (W*D*H)	250*190*71mm		
Package Size (W*D*H)	300*310*300mm		
Net Weight	5kg		
Gross Weight	6kg		

Benchtop pH Meter



PHS-25CW/3BW



PH-210

PHS-25CW/3BW Features:

- * Economical benchtop pH meter is equipped with a white backlit LCD display.
- * Automatic electrode slope display helps user decide whether to replace sensor.
- * Automatic Temperature Compensation ensures accurate measuring result.
- * 2 points push-button calibration with auto-buffer recognition.

PH-210 Features:

- * 1 to 3 points calibration with automatic recognition for USA and NIST buffers.
- * Automatic electrode diagnosis helps user decide whether to replace the pH electrode.
- * Automatic temperature compensation ensures accurate readings over the entire range.
- * Auto-Read function senses and locks the measurement endpoint.
- * Setup menu allows setting the pH buffer set, number of calibration points, temperature unit, etc.
- * Reset function automatically resumes all settings back to the factory defaults .

Accessories:

- * PH electrode.
- * Temperature probe (Only for PHS-3BW and PH-210 meter).
- * PH buffer pouches (pH4.01/7.00/10.01).
- * DC9V power adapter.



Technical Parameters:

Model		PHS-25CW	PHS-3BW	PH-210
pH	pH Range	0.00~14.00pH	0.00~14.00pH	-1.00~15.00pH
	pH Accuracy	±0.05pH	±0.01pH	±0.01pH
	Resolution	0.01pH	0.01pH	0.01pH
	Calibration Points	2 points	2 points	1~3 points
	Calibration Solutions	USA (pH4.01/7.00/10.01)	USA (pH4.01/7.00/10.01)	USA (pH4.01/7.00/10.01), NIST (pH4.01/6.86/9.18)
ORP	MV Range	-1999~1999mV	-1999~1999mV	-1999~1999mV
	MV Accuracy	±10mV	±1mV	±1mV
	Resolution	1mV	1mV	1mV
Temperature	Temperature Range	/	0~100°C	0~105°C, 32~221°F
	Temperature Accuracy	/	±1°C	±1°C/±1.8°F
	Resolution	/	1°C	0.1°C/0.1°F
	Offset Calibration	/	/	1 point, reading ±10°C
Other Specifications	Temperature Compensation	0~100°C, Manual	0~100°C, Manual or Automatic	0~100°C, 32~212°F, Manual or Automatic
	Hold Function	/	/	Manual or auto-endpoint
	Connector	BNC, 3.5 mm jack socket		BNC, 3.5 mm jack socket
	Display	Custom LCD		Custom LCD (120*60 mm)
	Power Requirements	DC9V/400mA power adapter		
	Dimensions(mm)	210*205*65		210*205*75
	Net Weight(kg)	1.5		
	Package Size(W*D*H)mm	310*240*180		
	Gross weight(kg)	1.7		

Benchtop pH/ORP/Ion Meter



pH:

- * 1 to 5 points calibration with automatic recognition for USA, NIST and DIN buffers.
- * Automatic electrode diagnosis shows the pH slope and offset.
- * Automatic temperature compensation ensures accurate readings over the entire range.
- * Calibration due alarm prompts user to calibrate the meter regularly.

ORP:

- * 1 point offset calibration allows adjusting the displayed value to a known standard.
- * Relative and absolute millivolt modes ensure the reliable ORP measurements. Ion Concentration (For PH-930).
- * 2 to 5 points calibration, including the 8 concentration points can be selected.
- * Direct ion concentration readout simplifies the measurement process.
- * Automatic electrode diagnosis shows the calibration points and slopes.
- * Selectable concentration units (ppm, mg/L, mol/L, mmol/L) and ionic valency.

General Features

- * Auto-Read function senses and locks the measurement endpoint.
- * Setup menu allows setting the pH buffer set, number of calibration points, resolution, stability criteria, temperature unit, date and time, etc.
- * Reset function automatically resumes all settings back to the factory defaults.
- * Expanded memory stores or recalls up to 500 data sets.
- * USB communication interface for data transfer and timed interval readings.

Accessories:

E201-BNC plastic body pH electrode, temperature probe, pH buffer sachets, electrode holder, DC5V power adapter.

Technical Parameters:

Model	PH-920	PH-930		
PH	Range	-2.000~20.000pH		
	Accuracy	±0.002pH		
	Resolution	0.1, 0.01, 0.001pH, Selectable		
	Calibration Points	1~5 points		
ORP	Calibration Solutions	USA, NIST, DIN, 2 custom buffers		
	MV Range	±1999.9mV		
	Relative mV Range	±1999.9mV		
	Resolution	0.1, 1mV, Selectable		
ORP	MV Accuracy	±0.2mV		
	Calibration Points	1 point		
	Ion	Range	/	0.001~19999ppm, mg/L, mol/L (depending on the range of ISE)
		Resolution	/	0.001, 0.01, 0.1, 1
Accuracy		/	±0.5% F.S (Monovalent), ±1% F.S (Divalent)	
Measurement Units		/	ppm, mg/L, mol/L, mmol/L	
Calibration Points		/	2 to 5 points	
Ion	Calibration Solutions	/	0.001, 0.01, 0.1, 1, 10, 100, 1000, 10000	
	Temperature	Range	0~105°C/32~221°F	
		Resolution	0.1°C/0.1°F	
		Accuracy	±0.5°C/±0.9°F	
		Offset Calibration	1 point, reading ±10°C	
Other Specifications	Temperature Compensation	0~100°C, Manual or Automatic		
	Stability Criteria	Low or high		
	Calibration Due Alarm	1 to 31 days or off		
	Slope/Offset Display	Yes		
	Hold Function	Manual or auto-endpoint		
	Memory	500 data sets		
	Communication Interface	USB		
	Connector	BNC, 3.5mm jack socket		
	Display	Custom LCD (125*100mm)		
	Power Requirements	DC5V power adapter		
	Dimensions(mm)	210*188*60mm		
Weight(kg)	1.5kg			
Package Size(W*D*H)mm	310*240*180mm			
Gross weight(kg)	1.7kg			

Portable Conductivity/TDS/Salinity Meter



PH-520/530/531/540

PH-520 Features:

- * 1 to 3 points calibration with automatic recognition for conductivity standards.
- * Automatic electrode diagnosis shows the calibration points and factors .
- * Selectable cell constant, reference temperature, linear/non-linear and pure water compensation modes.
- * Automatic temperature compensation ensures accurate readings over the entire range.
- * Auto-Read function senses and locks the measurement endpoint.
- * Setup menu allows setting the number of calibration points, temperature unit, auto-power off, etc.
- * Reset function automatically resumes all settings back to the factory defaults.
- * Expanded memory stores or recalls up to 100 data sets.
- * USB communication interface for data transfer or connecting a power adapter to meter.

PH-530/531/540 Features:

- * 1 to 5 points calibration with automatic recognition for conductivity standards.
- * Automatic electrode diagnosis shows the calibration points and factors.
- * Selectable cell constant, reference temperature, TDS factor, linear and pure water compensations, seawater and practical salinity measurement modes.
- * Automatic temperature compensation ensures accurate readings over the entire range.
- * Auto-Read function senses and locks the measurement endpoint.
- * Calibration due alarm prompts user to calibrate the meter regularly.
- * Auto-Power Off effectively conserves battery life.
- * Setup menu allows setting the number of calibration points, stability criteria, temperature unit, date and time, etc.
- * Reset function automatically resumes all settings back to the factory defaults.
- * Expanded memory stores or recalls up to 500 data sets.
- * USB communication interface is easy to transfer data to PC.
- * Multi-mode powerscheme (batteries, power adapter and USB port) ensures that using the meter smoothly.

Accessories:

Meter, CON-1 conductivity electrode, temperature probe, standard solutions and carrying case.

Technical Parameters:

Model	PH-520	PH-530	PH-531	PH-540
Conductivity	Range	Standard	CON-1: 2µs/cm~20000µs/cm	
		Optional	CON-0.01: 0.01µs/cm~0.1µs/cm; CON-0.1: 0.1µs/cm~2µs/cm; CON-10: 2000µs/cm~200ms/cm	
	Accuracy	±0.5% F.S.		
	Resolution	0.001, 0.01, 0.1, 1		
	Calibration Points	1 to 3 points (PH-520), 1 to 5 points (PH- 530/531/540)		
Calibration Solutions	10µs/cm, 84µS/cm, 1413µS/cm, 12.88mS/cm, 111.8mS/cm			
TDS	Range	/	0~10.00, 100.0, 1000ppm, 10.00, 200.0ppt	/
	Accuracy	/	±1% F.S.	/
	Resolution	/	0.01, 0.1, 1	/
	TDS Factor	/	0.1~1.0 (default 0.5)	/
Salinity	Range	/	0.00~42.00psu, 0.00~80.00ppt	
	Accuracy	/	±1% F.S.	
	Resolution	/	0.01	
Resistivity	Range	/	0.00~20.00MΩ	
	Accuracy	/	±1% F.S.	
	Resolution	/	0.01	
Temperature	Range	0~105°C/32~221°F		
	Accuracy	±0.5°C/±0.9°F		
	Resolution	0.1°C/0.1°F		
	Offset Calibration	1 point, reading ±10°C		
Other Specifications	Temperature Compensation	0~100°C, manual or automatic		
	Temperature Coefficient	Linear (0.0~10.0%/°C), non-linear, pure water		
	Reference Temperature	20/25°C		
	Cell Constant	K=0.1, 1, 10		
	Stability Criteria	/	Low or high	
	Calibration Due Alarm	/	1 to 31 days or off	
	Hold Function	Manual or auto-endpoint		
	Auto-Off	30 minutes after last key pressed (PH-520), 10, 20 or 30 minutes after last key pressed (PH-530/531/540)		
	Memory	100 data sets(PH-520), 500 data sets(PH-530/531/540)		
	Communication Interface	USB		
	Connector	6-pin nimi-DIN, 3.5mm jack socket		
	Display	Custom LCD (80*60mm)		
Power Requirements	3× 1.5V AA batteries or DC5V power adapter			
Battery Life	Approximately 150 hours (Turn off the backlight)			
Dimensions(mm)	170*85*30mm			
Weight(kg)	300g			
Package Size(W*D*H)mm	475*155*350mm			
Gross weight(kg)	2kg			

Benchtop Conductivity/TDS/Salinity/Resistivity Meter



Features:

- * 1 to 5 points calibration with automatic recognition for conductivity standards.
- * Automatic electrode diagnosis shows the calibration points and factors.
- * Selectable cell constant, reference temperature, TDS factor, linear and pure water compensations, seawater and practical salinity measurement modes.
- * Automatic temperature compensation ensures accurate readings over the entire range.
- * Auto-Read function senses and locks the measurement endpoint.
- * Calibration due alarm prompts user to calibrate the meter regularly.
- * Set up menu allows setting the number of calibration points, stability criteria, temperature unit, date and time, etc.
- * Reset function automatically resumes all settings back to the factory defaults.
- * Expanded memory stores or recalls up to 500 data sets.
- * USB communication interface for data transfer and timed interval readings.

Accessories:

Meter, CON-1 conductivity electrode, temperature probe, standard solutions, electrode holder, USB cable and power adapter.

Technical Parameters:

Model		PH-950	
Conductivity	Range	Standard	CON-1: 2µs/cm~20000µs/cm
		Optional	CON-0.01: 0.01µs/cm~0.1µs/cm; CON-0.1: 0.1µs/cm~2µs/cm; CON-10: 20000µs/cm~200ms/cm
	Accuracy	±0.5% F.S.	
	Resolution	0.001, 0.01, 0.1, 1	
	Calibration Points	1 to 5 points	
TDS	Calibration Solutions	10µS/cm, 84µS/cm, 1413µS/cm, 12.88mS/cm, 111.8mS/cm	
	Range	0~10.00, 100.0, 1000ppm, 10.00, 200.0ppt	
	Accuracy	±1% F.S.	
	Resolution	0.01, 0.1, 1	
Salinity	TDS Factor	0.1~1.0 (default 0.5)	
	Range	0.00~42.00psu, 0.00~80.00ppt	
	Accuracy	±1% F.S.	
Resistivity	Resolution	0.01	
	Range	0.00~20.00MΩ	
	Accuracy	±1% F.S.	
Temperature	Resolution	0.01	
	Range	0~105°C/32~221°F	
	Accuracy	±0.5°C/±0.9°F	
Other Specifications	Resolution	0.1°C/0.1°F	
	Offset Calibration	1 point, reading ±10°C	
	Temperature Compensation	0~100°C, manual or automatic	
	Temperature Coefficient	Linear (0.0~10.0%/°C), non-linear, pure water	
	Reference Temperature	20/25°C	
	Cell Constant	K=0.1, 1, 10	
	Stability Criteria	Low or high	
	Calibration Due Alarm	1 to 31 days or off	
	Calibration Factor Display	Yes	
	Hold Function	Manual or auto-endpoint	
	Memory	500 data sets	
	Communication Interface	USB	
	Connector	6-pin nimi-DIN, 3.5mm jack socket	
Display	Custom LCD (125*100mm)		
Power Requirements	DC5V power adapter		
Dimensions(mm)	210*188*60mm		
Weight(kg)	1.5kg		
Package Size(W*D*H)mm	310*240*180mm		
Gross weight(kg)	1.7kg		

Portable Dissolved Oxygen Meter



PH-820



PH-821



Features:

- * 1 or 2 points calibration using the air-saturated water or zero oxygen solution.
- * Salinity and barometric pressure compensations eliminate the measurement error.
- * Automatic temperature compensation ensures accurate readings over the entire range.
- * Auto-Read function senses and locks the measurement endpoint.
- * Auto-Power Off effectively conserves battery life.
- * Setup menu allows setting the number of calibration points, resolution, temperature unit, concentration unit, stability criteria, date and time, etc.
- * Reset function automatically resumes all settings back to the factory defaults.
- * Expanded memory stores or recalls up to 500 data sets.
- * USB communication interface for data transfer or connecting a power adapter to meter.

Accessories:

DO100 dissolved oxygen electrode, electrolyte solution, membrane cap and carrying case.

Technical Parameters:

Model		PH-820	PH-821
DO	Range	0.00~20.00mg/L, 0.0~200.0% saturation	
	Accuracy	±0.5mg/L, ±2.0%	±0.2mg/L, ±2.0%
	Resolution	0.01mg/L, 0.1%	
Other Specifications	Calibration Points	1 or 2 points	
	Temperature Compensation	0~50°C/32~122°F, automatic	
	Barometric Pressure Correction	60.0~112.5kPa/450~850mmHg, manual	
	Salinity Correction	0.0~50.0g/L, manual	
	Stability Criteria	/	Low or high
	Calibration Due Alarm	/	1 to 31 days or off
	Hold Function	Manual or auto-endpoint	
	Auto-Off	30 minutes after last key pressed	10, 20 or 30 minutes after last key pressed
	Memory	100 data sets	500 data sets
	Communication Interface	USB	
	Connector	6-pin nimi-DIN	
	Display	Custom LCD (80*60mm)	
	Power Requirements	3× 1.5V AA batteries or DC5V power adapter	
Dimensions(mm)	170*85*30mm		
Weight(kg)	300g		
Package Size(W*D*H)mm	475*155*350mm		
Gross weight(kg)	1.7kg		

Benchtop Dissolved Oxygen Meter



PH-810

PH-980

Features:

- * 1 or 2 points calibration using the air-saturated water or zero oxygen solution.
- * Salinity and barometric pressure compensations eliminate the measurement error.
- * Automatic temperature compensation ensures accurate readings over the entire range.
- * Auto-Read function senses and locks the measurement endpoint.
- * Setup menu allows setting the number of calibration points, concentration unit, temperature unit, etc.
- * Reset function automatically resumes all settings back to the factory defaults.
- * Calibration due alarm prompts user to calibrate the meter regularly.(only PH-980)
- * Set up menu allows setting the number of calibration points, resolution, stability criteria, temperature unit, concentration unit, date and time, etc.(only PH-980)
- * Expanded memory stores or recalls up to 500 data sets.(only PH-980)SD
- * USB communication interface for data transfer and timed interval readings.(only PH-980)

Accessories:

DO100 dissolved oxygen electrode, electrolyte solution, membrane cap and DC9V power adapter.

Technical Parameters:

Model	PH-810	PH-980
DO	Range	0.0~20.0mg/L or ppm
	Accuracy	±0.5mg/L
	Resolution	0.1mg/L
% saturation	Range	0.0~200.0%
	Accuracy	±2.0%
	Resolution	1%
Temperature	Range	0~60°C/32~140°F
	Accuracy	±1°C/±1.8°F
	Resolution	0.1°C/0.1°F
	Offset Calibration	1 point, reading ±10°C
Other Specifications	Dissolved Oxygen Calibration	1 or 2 points
	Temperature Compensation	0~40°C, automatic
	Barometric Pressure Correction	60.0~112.5kPa/450~850mmHg, manual
	Salinity Correction	0.0~35.0g/L, manual
	Stability Criteria	/
	Calibration Due Alarm	/
	Hold Function	Manual or auto-endpoint
	Memory	/
	Communication Interface	/
	Connector	6-pin nimi-DIN
	Display	Custom LCD (120*60mm)
	Power Requirements	DC9V power adapter
	Dimensions(mm)	210*205*75mm
Weight(kg)	1.5kg	
Package Size(W*D*H)mm	310*240*180mm	
Gross weight(kg)	1.7kg	

Portable Water Hardness Meter



Features:

- * 2 to 5 points calibration from low to high concentrations.
- * Selectable water hardness units - mmol/L, mg/L, German degree (°dH), English degree (°e) and French degree (°f).
- * Automatic temperature compensation ensures accurate readings over the entire range
- * Auto-Read function senses and locks the measurement endpoint.
- * Calibration due alarm prompts user to calibrate the meter regularly.
- * Auto-Power Off effectively conserves battery life.
- * Setup menu allows setting the number of calibration points, stability criteria, etc.
- * Reset function automatically resumes all settings back to the factory defaults.
- * Expanded memory stores or recalls up to 500 data sets.
- * USB communication interface for data transfer or connecting a power adapter to meter.



Accessories:

Water hardness electrode, temperature probe, standard solutions (10/100mmol/L), ionic strength adjuster and carrying.

Technical Parameters:

Model		PH-322
Water Hardness	Range	0.05~200mmol/L, 0~1122°dH, 0~2000°FH, 0~1404°e, 0~8020mg/L (Ca ²⁺), 0~19999mg/L (CaCO ₃), 0~11220mg/L (CaO)
	Resolution	0.001, 0.01, 0.1, 1
	Accuracy	±1% F.S.
	Calibration Points	2 to 5 points (0.01, 0.1, 1, 10, 100mmol/L)
Temperature	Range	0.0~105.0°C
	Resolution	0.1°C
	Accuracy	±0.5°C
	Offset Calibration	1 point, reading ±10°C
Other Specifications	Temperature Compensation	0~50°C, manual or automatic
	Hold Function	Manual or auto-endpoint
	Auto-Off	10, 20 or 30 minutes after last key pressed
	Memory	500 data sets
	Communication Interface	USB
	Connector	BNC, 3.5 mm jack socket
	Display	Custom LCD (80*60 mm)
	Power Requirements	3*1.5V AA batteries or DC5V power adapter
	Dimension	170*85*30mm
	Net Weight	300g
	Packing Size	475*155*350mm
	Gross Weight	2kg

Benchtop Water Hardness Meter



Features:

- * 2 to 5 points calibration from low to high concentrations.
- * Selectable water hardness units - mmol/L, mg/L, German degree (°dH), English degree (°e) and French degree (°f).
- * Automatic temperature compensation ensures accurate readings over the entire range.
- * Auto-Read function senses and locks the measurement endpoint.
- * Calibration due alarm prompts user to calibrate the meter regularly.
- * Setup menu allows setting the number of calibration points, stability criteria, etc.
- * Reset function automatically resumes all settings back to the factory defaults.
- * Expanded memory stores or recalls up to 500 data sets.
- * USB communication interface is easy to transfer data to PC.

Accessories:

Water hardness electrode, temperature probe, standard solutions (10/100mmol/L), ionic strength adjuster, electrode holder, USB cable and power adapter.

Technical Parameters:

Model		PH-932
Water Hardness	Range	0.05~200mmol/L, 0~1122°dH, 0~2000°fH, 0~1404°e, 0~8020mg/L (Ca ²⁺), 0~19999mg/L (CaCO ₃), 0~11220mg/L (CaO)
	Resolution	0.001, 0.01, 0.1, 1
	Accuracy	±1% F.S.
	Calibration Points	2 to 5 points (0.01, 0.1, 1, 10, 100mmol/L)
Temperature	Range	0.0~105.0°C
	Resolution	0.1°C
	Accuracy	±0.5°C
	Offset Calibration	1 point, reading ±10°C
Other Specifications	Temperature Compensation	0~50°C, manual or automatic
	Stability Criteria	Low or high
	Calibration Due Alarm	1 to 31 days or off
	Memory	500 data sets
	Communication Interface	USB
	Connector	BNC, 3.5 mm jack socket
	Display	Custom LCD (125*100mm)
	Power Requirements	DC5V power adapter
	Dimension	210*188*60mm
	Net Weight	1.5kg
	Packing Size	310*240*180mm
Gross Weight	1.7kg	

Portable Multiparameter Water Quality Meter



Features:

PH:

- * Multiparameter water quality meter is equipped with a 3.5 inches backlit LCD display.
- * 1 to 5 points calibration with automatic recognition for USA, NIST and DIN buffers.
- * Automatic electrode diagnosis shows the pH slope and offset.

ORP:

- * 1 point offset calibration allows adjusting the displayed value to a known standard.
- * Relative and absolute millivolt modes ensure the reliable ORP measurements.

Ion Concentration:

- * 2 to 5 points calibration, including the 8 concentration points can be selected.
- * Direct ion concentration readout simplifies the measurement process.
- * Automatic electrode diagnosis shows the calibration points and slopes.
- * Selectable concentration units (ppm, mg/L, mol/L, mmol/L) and ionic valency.

Conductivity/TDS/Salinity/Resistivity:

- * 1 to 5 points calibration with automatic recognition for conductivity standards.
- * Selectable cell constant, reference temperature, TDS factor, linear and pure water compensations, seawater and practical salinity measurement modes.

- * Automatic electrode diagnosis shows the calibration points and factors.

Dissolved Oxygen:

- * 1 or 2 points calibration using the air-saturated water or zero oxygen solution.
- * Salinity and barometric pressure compensations eliminate the measurement error.

Other Features:

- * Automatic temperature compensation ensures accurate readings over the entire range.
- * Auto-Read function senses and locks the measurement endpoint.
- * Calibration due alarm prompts user to calibrate the meter regularly.
- * Auto-Power Off effectively conserves battery life.
- * Setup menu allows setting the number of calibration points, resolution, stability criteria, temperature unit, date and time, etc..
- * Reset function automatically resumes all settings back to the factory defaults.
- * Expanded memory stores or recalls up to 500 data sets.
- * USB communication interface is easy to transfer data to PC.
- * Multi-mode power scheme (batteries, power adapter and USB port) ensures that using the meter smoothly.



Accessories:

pH/conductivity/dissolved oxygen electrode, temperature probe, pH standard buffer, conductivity standard solutions, dissolved oxygen electrolyte, membrane cap, carrying case.

Technical Parameters:

Model	PH-900P	
pH	Range	-2.000~20.000pH
	Resolution	0.001, 0.01, 0.1pH, selectable
	Accuracy	±0.002pH
	Calibration Points	1 to 5 points
ORP(optional)	pH Buffer Options	USA, NIST, DIN, 2 custom buffers
	Range	±1999.9mV
	Resolution	0.1, 1mV, selectable
	Accuracy	±0.2mV
Ion(optional)	Calibration Points	1 point
	Range	0.001~19999 (depending on the range of ISE)
	Resolution	0.001, 0.01, 0.1, 1
	Accuracy	±0.5% F.S. (monovalent), ±1% F.S. (divalent)
Conductivity	Measurement Units	ppm, mg/L, mol/L, mmol/L
	Calibration Points	2 to 5 points (0.001, 0.01, 0.1, 1, 10, 100, 1000, 10000)
	Range	0.001~19999 (depending on the range of ISE)
	Resolution	0.001, 0.01, 0.1, 1
TDS	Accuracy	±0.5% F.S.
	Calibration Points	1 to 5 points
	Calibration Solutions	10µS/cm, 84µS/cm, 1413µS/cm, 12.88mS/cm, 111.8mS/cm
	Temperature Coefficient	Linear (0.0~10.0%/°C), pure water
Salinity	Reference Temperature	20/25°C
	Cell Constant	K=0.1, 1, 10 or custom
	Range	0~10.00, 100.0, 1000ppm, 10.00, 200.0ppt
	Resolution	0.01, 0.1, 1
Resistivity	Accuracy	±1% F.S.
	TDS Factor	0.1~1.0 (default 0.5)
	Range	0.00~42.00psu, 0.00~80.00ppt
	Resolution	0.01
DO	Accuracy	±1% F.S.
	Range	0.00~20.00mg/L, 0.0~200.0% saturation
	Resolution	0.01mg/L, 0.1%
	Accuracy	±0.2mg/L, ±2.0%
Other Specifications	Calibration Points	1 or 2 points
	Barometric Pressure Correction	60.0~112.5kPa/450~850mmHg, manual
	Salinity Correction	0.0~50.0g/L, manual
	Temperature Compensation	0~100°C/32~212°F, manual or automatic
Other Specifications	Memory	500 data sets, USB communication interface
	Power Requirements	3*1.5V AA batteries or DC5V power adapter
	Dimension	170*85*30mm
	Net Weight	300g
Other Specifications	Packing Size	450*320*100mm
	Gross Weight	2kg

Benchtop Multiparameter Water Quality Meter



Features:

pH:

- * Multiparameter water quality meter is equipped with a 6.5 inches backlit LCD display 1 to 5 points calibration with automatic recognition for USA, NIST and DIN buffers.
- * Automatic electrode diagnosis shows the pH slope and offset.

ORP:

- * 1 point offset calibration allows adjusting the displayed value to a known standard.
- * Relative and absolute millivolt modes ensure the reliable ORP measurements.

Ion Concentration:

- * 2 to 5 points calibration, including the 8 concentration points can be selected.
- * Direct ion concentration readout simplifies the measurement process.
- * Automatic electrode diagnosis shows the calibration points and slopes.
- * Selectable concentration units (ppm, mg/L, mol/L, mmol/L) and ionic valency.

Conductivity/TDS/Salinity/Resistivity:

- * 1 to 5 points calibration with automatic recognition for conductivity standards.
- * Selectable cell constant, reference temperature, TDS factor, linear and pure water compensations, seawater and practical salinity measurement modes.
- * Automatic electrode diagnosis shows the calibration points and factors.

Dissolved Oxygen:

- * 1 or 2 points calibration using the air-saturated water or zero oxygen solution
- * Salinity and barometric pressure compensations eliminate the measurement error

Other Features:

- * Automatic temperature compensation ensures accurate readings over the entire range.
- * Auto-Read function senses and locks the measurement endpoint.
- * Calibration due alarm prompts user to calibrate the meter regularly.
- * Setup menu allows setting the number of calibration points, resolution, stability criteria, temperature unit, date and time, etc.
- * Reset function automatically resumes all settings back to the factory defaults.
- * Expanded memory stores or recalls up to 500 data sets.
- * USB communication interface for data transfer and timed interval readings.

Accessories:

pH/conductivity/dissolved oxygen electrodes, temperature probe, pH buffer sachets, conductivity standard solutions, DO electrolyte solution, membrane cap, electrode holder, USB cable and power adapter

Technical Parameters:

Model		PH-900
pH	Range	-2.000~20.000pH
	Resolution	0.001, 0.01, 0.1pH, selectable
	Accuracy	±0.002pH
	Calibration Points	1 to 5 points
	pH Buffer Options	USA, NIST, DIN, 2 custom buffers
ORP(optional)	Range	±1999.9mV
	Resolution	0.1, 1mV, selectable
	Accuracy	±0.2mV
	Calibration Points	1 point
Ion(optional)	Range	0.001~19999 (depending on the range of ISE)
	Resolution	0.001, 0.01, 0.1, 1
	Accuracy	±0.5% F.S. (monovalent), ±1% F.S. (divalent)
	Measurement Units	ppm, mg/L, mol/L, mmol/L
Conductivity	Calibration Points	2 to 5 points (0.001, 0.01, 0.1, 1, 10, 100, 1000, 10000)
	Range	0.1~2µS/cm(CON-0.1, optional); 2~20mS/cm(CON-1, standard); 20~200mS/cm(CON-10, optional)
	Resolution	0.001, 0.01, 0.1, 1
	Accuracy	±0.5% F.S.
	Calibration Solutions	10µS/cm, 84µS/cm, 1413µS/cm, 12.88mS/cm, 111.8mS/cm
	Temperature Coefficient	Linear (0.0~10.0%/°C), pure water
TDS	Reference Temperature	20/25°C
	Cell Constant	K=0.1, 1, 10 or custom
	Range	0~10.00, 100.0, 1000ppm, 10.00, 200.0ppt
	Resolution	0.01, 0.1, 1
	Accuracy	±1% F.S.
	TDS Factor	0.1~1.0 (default 0.5)
Salinity	Range	0.00~42.00psu, 0.00~80.00ppt
	Resolution	0.01
	Accuracy	±1% F.S.
Resistivity	Range	0.00~20.00MΩ
	Resolution	0.01
	Accuracy	±1% F.S.
DO	Range	0.00~20.00mg/L, 0.0~200.0% saturation
	Resolution	0.01mg/L, 0.1%
	Accuracy	±0.2mg/L, ±2.0%
	Calibration Points	1 or 2 points
	Barometric Pressure Correction	60.0~112.5kPa/450~850mmHg, manual
	Salinity Correction	0.0~50.0g/L, manual
Other	Temperature Compensation	0~100°C/32~212°F, manual or automatic
	Memory	500 data sets, USB communication interface
Specifications	Power Requirements	DC5V power adapter
	Dimension	210*188*60mm
	Net Weight	1.5kg
	Packing Size	300*250*200mm
	Gross Weight	1.7kg

Spectrophotometer

Micro-Volume UV/VIS Spectrophotometer

Features:

- * The uniquely designed sample holder can test a small amount of DNA and protein.
- * Detection is rapid, drop sample - rotation - detection
- * The whole measurement process without light loss, to ensure the accuracy of the results
- * The function can be expanded, and can complete quantitative testing, wavelength scanning, kinetics, multi-wavelength and other functions, and can also be used for conventional colorimetric blood measurement.



Technical Parameters:

Model	BK-CW500
Minimum Sample Capacity	0.2µl
Ultramicro Optical Distance	0.5mm
Detectable Concentration Range	2.5~7500ng/ul(dsDNA)
Min Precise Detect Concentration	10ng/µl (dsDNA)
Max Precise Detect Concentration	5000ng/µl (dsDNA)
DNA reproducibility	< ±1.0 % (dsDNA, @ 1000ng/µl)
Wavelength Range	190~1100nm
Spectral Bandwidth	4nm
Optical System	Grating Double beam
Wavelength Accuracy	±0.5nm
Wavelength Repeatability	0.3nm
Max Scanning Speed	4000nm/min
Photometric Accuracy	±0.5%T or ±0.004A @ 1A
Photometric Range	0~200%T, -0.3~0.3A, 0~9999Conc
Stray Light	0.05%T @ 220, 340nm
Stability	±0.001A/h @ 500nm
Baseline Flatness	±0.002A
Light Source	Halogen & Deuterium lamp
Output	USB Print and data output, Connect PC
Power Supply	AC110/220V±10%, 50/60Hz
Package Size(W*D*H)mm	480*600*360
Gross Weight(kg)	11

Application:

Micro-Volume Spectrophotometer is used for quantitative and qualitative research by spectrophotometry. It is usually used in quantitative research of nucleic acid, proteins and bacterial concentration.



BK-CW1000

BK-CW2000

Features:

- * Most samples don't need dilute.
- * Microscale sample test, minimum 0.5µl.
- * PC control, more accurate and flexible.
- * Ultramicro and cuvette dual platform (Only for BK-CW2000).
- * Wide test area, 100 times of the traditional spectrophotometer.
- * Test directly without warming up, do not need detection container, lower daily consumption.

Technical Parameters:

Model	BK-CW1000	BK-CW2000
Minimum Sample Capacity	0.5µl	
Ultramicro Optical Distance	1mm/0.2mm	1mm/0.2mm/0.05mm
Cuvette Optical Distance	/	10mm/5mm/2mm/1mm
Whole Wavelength	190~1100nm	
Scanning Wavelength	190~850nm	
Wavelength Accuracy	1nm	
Wavelength Resolution	≤0.3nm (FWHM @ Hg 253.7nm)	
Absorbance Accuracy	2% (0.76 @ 257nm)	
Absorbance Resolution	0.002Abs (1mm)	
Absorbance Range	0.02~300(10mm)	0.005~300 (10mm)
Test Accuracy	0.1~5 Abs. ±0.1 Abs 5~80 Abs. ±2%	0.01~0.5 Abs. ±0.01Abs 0.5~80 Abs. ±2%
Test Time	5s	
Detector	3648 pixel linear CCD array	
Light Source	Xenon flash lamp	
Sample Test Platform Material	304 stainless steel and quartz	
Standard Accessories	• Driver software CD 1 pc • Power line 1 pc • Power Adapter 1 pc	
Consumption	24W	
Power Supply	AC110/220V±10%, 50/60Hz	
External Size(W*D*H)mm	200*130*136	
Package Size(W*D*H)mm	310*310*310	
Net Weight(kg)	2.5	
Gross Weight(kg)	5	

UV-Vis Spectrophotometer



Introduction:

The UV-Vis Spectrophotometer is an analytical instrument based on the principle of ultraviolet visible spectrophotometry, which uses the radiation absorption of molecules in the ultraviolet visible spectral region for analysis. It is widely used in various fields such as medicine and health, environmental monitoring, life sciences, drug analysis, food analysis, organic chemistry, biochemistry, etc.



Glass Cuvette for visible area determination
Quartz Cuvette for ultraviolet light area determination



Deuterium Lamp:
Ultraviolet light source



Tungsten Lamp:
Visible light source

Features:

- * 10.1-inch full color touch screen display, which can directly display various scanning curves and graphs without the need for a computer.
- * The standard USB Bluetooth function can realize wired and wireless storage, and one-click screenshots can export data pictures in real time.
- * It adopts advanced A6 core high-performance processor, and optional mouse and keyboard.
- * Nucleic acid and protein concentration determination function, rapid detection of nucleic acid extraction purity.
- * Qualitative and quantitative analysis capabilities to test unknown substances and known sample concentrations.
- * Upper-computer software and printer are optional.

Technical Parameters:

Model	UV-1100
Display	10.1-inch LCD touch screen
Optical System	Single beam
Light Source	International famous deuterium lamp, tungsten lamp
Wavelength	190nm-1100nm
Stray Light	0.05% (220nm)
Spectral Bandwidth	2nm
Wavelength Accuracy	Full wavelength 0.3nm(656.1nm 0.1nm)
Wavelength Repeatability	0.1nm
Transmittance Accuracy	0.3%T
Photometric Mode	Transmittance, absorbance, concentration, energy
Interface	RS-232 USB
Power Supply	AC220V 50/60Hz, 110V 60Hz (optional)
External Size (L*W*H)	562*520*260mm
Net Weight	21kg
Package Size (L*W*H)	612*522*322mm
Gross Weight	24kg

UV/VIS Spectrophotometer



Introduction:

It is based on the absorption spectrum of substances to study the composition of substances, structure and interaction between substances, with a wide wavelength range, high sensitivity, simple operation, simple structure, beautiful appearance and other advantages, can be widely used in chemical, pharmaceutical, biochemistry, metallurgy, light industry, textile, materials, environmental protection, medical laboratory and education and other industries. It is one of the important quality control instruments in the analytical test industry, and is a necessary instrument in conventional laboratories.



Biochemistry



Petrochemicals

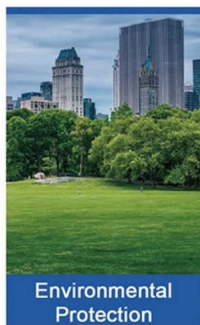

Environmental Protection



Metallurgy

Features:

- * 1200L/mm grating
- * Imported long life deuterium lamp, tungsten lamp
- * LCD Integrated display
- * Wide capacity voltage
- * Power-on self-test
- * High sensitivity photoconverter

Technical Parameters:

Model	BK-UV1000G	BK-V1000G
Optical System	Single beam, grating 1200L/mm	
Wavelength	200-1020nm	325-1020nm
Spectral Bandwidth	4nm	
Wavelength Accuracy	±1.5nm	
Wavelength Repeatability	≤0.2nm	
Photometric Accuracy	+0.002Abs (0-0.5Abs), ±0.004A (0.5-1.0Abs), ±0.4%T (0-100%T)	
Photometric Repeatability	0.001Abs(0-0.5Abs), 0.002Abs(0.5-1.0Abs), <0.2%T (0-100%T)	
Stray Light	≤0.1%T(220nm,360nm)	
Stability	±0.001A/h(500nm)	
Photometric Range	-0.301-3.0A 0-200%T 0-9999C	
Photometric Mode	A T C E	
Wavelength Setting	Automatic	
Output	RS232 printer data output, USB-B connection	
Detector	Imported silicon photodiode	
Light Source	Deuterium lamp, tungsten lamp	Tungsten lamp
Standard Accessories	4*glass cuvette, 2*quartz cuvette	4*glass cuvette
Power Supply	100-220V 50/60Hz	
External Size	466*384*201mm	
Net Weight	11.6kg	
Packing Size	590*480*315mm	
Gross Weight	14.4kg	14kg

UV/VIS Spectrophotometer



Introduction:

It is based on the absorption spectrum of substances to study the composition of substances, structure and interaction between substances, with a wide wavelength range, high sensitivity, simple operation, simple structure, beautiful appearance and other advantages, can be widely used in chemical, pharmaceutical, biochemistry, metallurgy, light industry, textile, materials, environmental protection, medical laboratory and education and other industries. It is one of the important quality control instruments in the analytical test industry, and is a necessary instrument in conventional laboratories.



Biochemistry



Petrochemicals

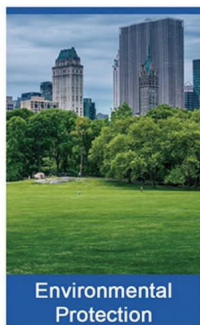

Environmental Protection



Metallurgy

Features:

- * 1200L/mm grating
- * Imported long life deuterium lamp, tungsten lamp
- * 7-inch LCD display
- * Wide capacity voltage
- * Power-on self-test
- * High sensitivity photoconverter

Technical Parameters:

Model	BK-UV1600G	BK-V1600G
Optical System	Single beam, grating 1200L/mm	
Wavelength	190-1100nm	325-1100nm
Spectral Bandwidth	4nm	
Wavelength Accuracy	±1.5nm	
Wavelength Repeatability	≤0.2nm	
Photometric Accuracy	+0.002Abs (0-0.5Abs), ±0.004A (0.5-1.0Abs), ±0.4%T (0-100%T)	
Photometric Repeatability	0.001Abs(0-0.5Abs), 0.002Abs(0.5-1.0Abs), <0.2%T (0-100%T)	
Stray Light	≤0.05%T(220nm,360nm)	
Stability	±0.001A/h(500nm)	
Photometric Range	-0.301-3.0A 0-200%T 0-9999C	
Photometric Mode	A T C E	
Wavelength Setting	Automatic	
Output	RS232 printer data output, USB-A connection, wireless printing, mobile phone PC connection	
Detector	Imported silicon photodiode	
Light Source	Deuterium lamp, tungsten lamp	Tungsten lamp
Standard Accessories	4*glass cuvette, 2*quartz cuvette	4*glass cuvette
Power Supply	100-220V 50/60Hz	
External Size	466*365*200mm	
Net Weight	11.25kg	
Packing Size	590*480*315mm	
Gross Weight	15.4kg	15kg

UV/VIS Spectrophotometer

Basic Functions:

Model	Optical System	Wavelength Range	Bandwidth	Photo-metry	QTY	MULT	KINS	Scanning	Bio
BK-V1000	Single Beam	325-1020nm	4nm	•					
BK-UV1000	Single Beam	200-1020nm	4nm	•					
BK-V1200	Single Beam	325-1020nm	4nm	•	•				
BK-UV1200	Single Beam	200-1020nm	4nm	•	•				
BK-V1600	Single Beam	320-1100nm	4nm	•	•	•	•		
BK-UV1600	Single Beam	190-1100nm	4nm	•	•	•	•		
BK-V1800	Single Beam	320-1100nm	2nm	•	•	•	•		
BK-UV1800	Single Beam	190-1100nm	2nm	•	•	•	•		
BK-V1900	Single Beam	320-1100nm	2nm	•	•	•	•	•	•
BK-UV1900	Single Beam	190-1100nm	2nm	•	•	•	•	•	•
BK-S360	Single Beam	190-1100nm	1.8nm	•	•	•	•	•	•
BK-S380	Single Beam	190-1100nm	1nm	•	•	•	•	•	•
BK-S390	Single Beam	190-1100nm	0.5, 1, 2, 4, 5nm	•	•	•	•	•	•
BK-D560	Double Beam	190-1100nm	1.8nm	•	•	•	•	•	•
BK-D580	Double Beam	190-1100nm	1nm	•	•	•	•	•	•
BK-D590	Double Beam	190-1100nm	0.5, 1, 2, 4, 5nm	•	•	•	•	•	•

Features:

- * Large LCD screen (128*64 Dots).
- * Pre-aligned design ensures the user can change lamps conveniently.
- * With SiO₂ coating optical mirror, reducing the pollution from outside fully.
- * Environmental Deuterium lamp, preventing from Ozone inhalation.
- * High-class grating, wholly hermetic light path design, ensures the super low stray light.
- * Real-time monitoring the lifetime of Deuterium lamp and Tungsten lamp with advanced system.
- * Wavelength calibration, wavelength setting, change lamp source and dark current calibration automatically.
- * Optional PC Software to expand the applications to Quantitative, Multi-Wavelength and Kinetics.
- * Widely used for Organic chemistry, Inorganic chemistry, Life sciences, food, Medicine and health, Agriculture, Geology, Metallurgy and Environment etc. fields.



BK-UV/V1000/1200

Basic Functions:

* Photometry

Test Abs, Transmittance by fixed wavelength.

* Quantitative

- C Mode: Establish C=K*A curve, test sample concentration.
- F Mode: Establish A=K1*C+K0, test sample concentration.
- Display and save curve, test data (BK-V1200).

WL : 546.0			
T : 100.0			
A	T	C	F

Photometry Mode

WL : 546.0			
C : 10C			
A	T	C	F

Con. Test C=K*A+B

Technical Parameters:

Model	BK-UV1000	BK-V1000	BK-UV1200	BK-V1200
Optical System	Single Beam, Grating 1200 lines/mm			
Wavelength Range	200~1100nm	325~1100nm	195~1100nm	320~1100nm
Spectral Bandwidth	4nm			
Wavelength Accuracy	±1.8nm		±1.0nm	
Wavelength Repeatability	≤0.5nm			
Photometric Accuracy	±0.002A (0~0.5Abs), ±0.004A (0.5~1.0Abs), ±0.5% T (0~100% T)			
Photometric Repeatability	0.001Abs (0~0.5Abs), 0.002Abs (0.5~1.0Abs), ≤0.2% T (0~100% T)			
Stray Light	≤ 0.2 % T @ 360nm; 220nm(UV)		≤ 0.2% T @ 360nm(V)	
Stability	± 0.002A/h@500nm			
Noise	±0.001A			
Display	128*64 Dots LCD			
Photometric Mode	T, A, C, E			
Photometric Range	0~200%T, -0.301~3.0A			
Detector	Silicon Photodiode			
Light Source	Deuterium Lamp, Tungsten Lamp			
Input	Membrane Keypad			
Output	Parallel Print, USB1.0			
Standard Accessories	1cm glass cuvette*4, 1cm quartz cuvette*2, 1cmquadruple cuvette holder*1	1cm glass cuvette*4, 1cmquadruple cuvette holder*1	1cm glass cuvette*4, 1cm quartz cuvette*2, 1cmquadruple cuvette holder*1	1cm glass cuvette*4, 1cmquadruple cuvette holder*1
Optional Accessories	General application software, 1cm standard single slot cuvette holder, long optical path cuvette holder, cuvette, micro cuvette, test tube type absorber rack, solid sample holder, deuterium lamp(only for UV series), tungsten lamp, quadruple cuvette holder, printer, four-slot water bath type constant temperature absorption pool, X-Y Adjustable Micro Absorption Pool, single bath type constant temperature absorption pool			
Package Size(W*D*H) mm	560*430*320	560*430*320	560*430*320	560*430*320
Gross Weight(kg)	12	11.5	12	11.5

UV/VIS Spectrophotometer

Features:

- * With SiO₂ coating optical mirror, reducing the pollution from outside fully
- * Wavelength calibration, wavelength setting, change lamp source and dark current calibration automatically
- * With GLP self-check function, check the wavelength accuracy and Photometry accuracy
- * PC Software to expand the applications to Quantitative, Multi-Wavelength and Kinetics, Spectrum Scanning, DNA/Protein test for PC Series



Basic Functions:

- * **Photometry**
Test Abs., Transmittance and Energy by fixed wavelength.
- * **Kinetics**
Used for time course scanning or reaction rate calculations $\Delta A/t$, can search all data.
- * **Multi-Wavelength**
Can test Transmittance and Abs. with 8 different wavelengths at most
- * **Quantitative**
Linear fit and Linear fit through zero two modes
 - Coefficient, Standard Sample input and Standard Sample read three modes to establish standard curve.
 - Establish $A=K1 \cdot C+K0$, can search original data, graph curve, parameters settings
 - Can save 240 group curves, can test 240 data in each curve.
 - Double wavelength, Triple wavelength test functions.

Technical Parameters:

Model	BK-UV1800 BK-UV1800PC	BK-UV1600 BK-UV1600PC	BK-V1800 BK-V1800PC	BK-V1600 BK-V1600PC
Optical System	Single Beam, Grating 1200 lines/mm			
Wavelength Range	190~1100nm		320~1100nm	
Spectral Bandwidth	2nm	4nm	2nm	4nm
Wavelength Accuracy	±0.5nm			
Wavelength Repeatability	≤0.2nm			
Photometric Accuracy	±0.002A (0~0.5Abs), 0.004A (0.5~1.0Abs), ±0.5% T (0~100% T)			
Photometric Repeatability	0.001Abs (0~0.5Abs), 0.002Abs (0.5~1.0Abs), ≤0.2% T (0~100% T)			
Stray Light	≤0.04% T @ 360nm; 220nm		≤0.04% T @ 360nm	
Stability	±0.001A/h @ 500nm			
Baseline Flatness	±0.002A			
Noise	±0.0005A			
Display	480*272 65 thousand true color TFT LCD			
Photometric Mode	T, A, C, E			
Photometric Range	0~200% T, -0.301~3.0A			
Detector	Silicon Photodiode			
Light Source	Deuterium Lamp, Tungsten Lamp			
Input	Membrane Keypad			
Output	USB-A*2 Print and data output USB-B Connect PC			
Standard Accessories	1cm glass cuvette*4, 1cm quartz cuvette*2, 1cm quadruple cuvette holder*1, Scanning software(only for PC type)		1cm glass cuvette*4, 1cm quadruple cuvette holder*1, Scanning software(only for PC type)	
Optional Accessories	1cm standard single slot cuvette holder, long optical path cuvette holder, cuvette, micro cuvette, test tube type absorber rack, solid sample holder, deuterium lamp(only for UV series), tungsten lamp, quadruple cuvette holder, printer, four-slot water bath type constant temperature absorption pool, X-Y Adjustable Micro Absorption Pool, single bath type constant temperature absorption pool, program-controlled thermostatic absorption pool seat, 8 racks, reflection accessories, general application software or Scanning software(not for PC type)			
Power Supply	AC110/220V±10%, 60/50Hz			
Package Size(W*D*H)mm	620*500*370	620*500*370	620*500*370	620*500*370
Gross Weight(kg)	18	18	16.5	16.5

Scanning UV/VIS Spectrophotometer

Features:

- * With SiO₂ coating optical mirror, reducing the pollution from outside fully
- * Adopted high-class grating with wholly hermetic light path design, to ensure the instrument has the super low stray light
- * With GLP self-check function, check the wavelength accuracy and Photometry accuracy
- * Real-time monitoring the lifetime of Deuterium lamp and Tungsten lamp with advanced system
- * Wavelength calibration, wavelength setting, change lamp source and dark current calibration automatically



Basic Functions:

- * **Photometry**
Test Abs., Transmittance and Energy by fixed wavelength.
- * **Quantitative**
Linear fit and Linear fit through zero two modes
 - Coefficient, Standard Sample input and Standard Sample read three modes to establish standard curve.
 - Establish $A=K1 \cdot C+K0$, can search original data, graph curve, parameters settings.
 - Can save 240 group curves, can test 240 data in each curve.
 - Double wavelength, Triple wavelength test functions.
- * **Kinetics**
Used for time course scanning or reaction rate calculations $\Delta A/t$, can search all data.
- * **Multi-Wavelength**
Can test Transmittance and Abs. with 8 different wavelengths at most.
- * **Scanning**
User can set the scan range from 190nm to 1100nm to test the max. Abs. peak value, can do derivation, arithmetical operations to the graph.
- * **Biology**
6 methods: DNA/Protein, UV, Lowry, BCA, CBB and Biuret.

Technical Parameters:

Model	BK-UV1900 BK-UV1900PC	BK-V1900 BK-V1900PC
Optical System	Single Beam, Grating 1200 lines/mm	
Wavelength Range	190~1100nm	320~1100nm
Spectral Bandwidth	2nm	
Wavelength Accuracy	±0.5nm	
Wavelength Repeatability	≤0.2nm	
Photometric Accuracy	±0.002A (0~0.5Abs), ±0.004A (0.5~1.0Abs), ±0.5% T (0~100% T)	
Photometric Repeatability	0.001Abs (0~0.5Abs), 0.002Abs (0.5~1.0Abs), ≤0.2% T (0~100% T)	
Stray Light	≤0.04% T @ 360nm; 220nm	
Stability	±0.001A / h @ 500nm	
Baseline Flatness	±0.002A	
Noise	0.0005Abs @ 500nm	
Display	480*272 65 thousand true color TFT LCD	
Photometric Mode	T, A, C, E	
Photometric Range	0~200% T, -0.301~3.0A	
Detector	Silicon Photodiode	
Light Source	Deuterium Lamp, Tungsten Lamp	
Input	Membrane Keypad	
Output	USB Print and data output, Connect PC	
Standard Accessories	1cm glass cuvette*4, 1cm quartz cuvette*2, 1cm quadruple cuvette holder*1, Scanning software(only for PC type)	1cm glass cuvette*4, 1cm quadruple cuvette holder*1, Scanning software(only for PC type)
Optional Accessories	1cm standard single slot cuvette holder, long optical path cuvette holder, cuvette, micro cuvette, test tube type absorber rack, solid sample holder, deuterium lamp(only for UV series), tungsten lamp, quadruple cuvette holder, printer, four-slot water bath type constant temperature absorption pool, X-Y Adjustable Micro Absorption Pool, single bath type constant temperature absorption pool, program-controlled thermostatic absorption pool seat, 8 racks, reflection accessories, general application software or Scanning software(not for PC type)	
Power Supply	AC110V/220±10%, 60/50Hz	
Package Size(W*D*H)mm	620*500*370	620*500*370
Gross Weight(kg)	18	16.5

Scanning UV/VIS Spectrophotometer

Features:

- * Environmental Deuterium lamp, preventing from Ozone inhalation
- * Socket-Type Deuterium lamp and Tungsten lamp
- * SiO₂ coating optical mirror, reduces the influence from outside
- * GLP self-check function: check the wavelength accuracy and Photometry accuracy, provide test report and power-off protection
- * Wavelength calibration, wavelength setting, change lamp source and dark current calibration automatically



Basic Functions:

- * **Photometry**
Test Abs., Transmittance and Energy by fixed wavelength.
- * **Quantitative**
Linear fit and Linear fit through zero two modes
a. Coefficient, Standard Sample input and Standard Sample read three modes to establish standard curve.
b. Establish $A=K1 \cdot C+K0$, can search original data, graph curve, parameters settings.
c. Can save 240 group curves, can test 240 data in each curve.
d. Double wavelength, Triple wavelength test functions.
- * **Kinetics**
Used for time course scanning or reaction rate calculations $\Delta A/t$, can search all data.
- * **Multi-Wavelength**
Can test Transmittance and Abs. with 8 different wavelengths at most.
- * **Scanning**
User can set the scan range from 190nm to 1100nm to test the max. Abs. peak value, can do derivation, arithmetical operations to the graph.
- * **Biology**
DNA/Protein, (Optional: UV, Lowry, BCA, CBB and Biuret)

Technical Parameters:

Model	BK-S360	BK-S380	BK-S390
Optical System	Single Beam, Grating 1200 lines/mm		
Wavelength Range	190~1100nm		
Spectral Bandwidth	1.8nm	1nm	0.5, 1, 2, 4, 5nm
Wavelength Accuracy	±0.3nm		
Wavelength Repeatability	≤0.2nm		
Photometric Accuracy	±0.002A (0~0.5Abs), ±0.004A (0.5~1.0Abs), ±0.3% T (0~100% T)		
Photometric Repeatability	0.001Abs (0~0.5Abs), 0.002Abs (0.5~1.0Abs), ≤0.1% T (0~100% T)		
Stray Light	≤0.04% T @ 360nm; 220nm		
Stability	±0.001A/h @ 500nm		
Baseline Flatness	±0.0015A		
Noise	±0.0004Abs		
Display	65 thousand true color 7 inch TFT LCD (480*800)		
Photometric Mode	T, A, C, E		
Photometric Range	0~200% T, -0.301~3.0A		
Detector	Silicon Photodiode		
Light Source	Deuterium Lamp, Tungsten Lamp		
Input	Membrane Keypad		
Output	USB-A*2 Print and data output USB-B Connect PC		
Standard Accessories	1cm glass cuvette*4, 1cm quartz cuvette*2, 1cm quadruple cuvette holder, scanning software		
Optional Accessories	1cm standard single slot cuvette holder, long optical path cuvette holder, cuvette, micro cuvette, test tube type absorber rack, solid sample holder, deuterium lamp, tungsten lamp, quadruple cuvette holder, printer, four-slot water bath type constant temperature absorption pool, X-Y Adjustable Micro Absorption Pool, single bath type constant temperature absorption pool, program-controlled thermostatic absorption pool seat, 8 racks, reflection accessories		
Power Supply	AC110V/220±10%, 60/50Hz		
Package Size(W*D*H) mm	740*570*440		
Gross Weight(kg)	25		

Double Beam Scanning UV/VIS Spectrophotometer

Features:

- * Environmental Deuterium lamp, preventing from Ozone inhalation
- * Real-time monitoring the lifetime of Deuterium lamp and Tungsten lamp
- * Socket-Type Deuterium lamp and Tungsten lamp
- * GLP self-check function: check the wavelength accuracy and Photometry accuracy, provide test report and power-off protection
- * Wavelength calibration, wavelength setting, change lamp source and dark current calibration automatically
- * SiO₂ coating optical mirror, reduces the influence from outside

















Basic Functions:

- * **Photometry**
Test Abs., Transmittance and Energy by fixed wavelength.
- * **Quantitative**
Linear fit and Linear fit through zero two modes
a. Coefficient, Standard Sample input and Standard Sample read three modes to establish standard curve.
b. Establish $A=K1 \cdot C+K0$, can search original data, graph curve, parameters setting
c. Can save 240 group curves, can test 240 data in each curve.
d. Double wavelength, Triple wavelength test functions.
- * **Kinetics**
Used for time course scanning or reaction rate calculations $\Delta A/t$, can search all data.
- * **Multi-Wavelength**
Can test Transmittance and Abs. with 8 different wavelengths at most.
- * **Scanning**
User can set the scan range from 190nm to 1100nm to test the max. Abs. peak value, can do derivation, arithmetical operations to the graph.
- * **Biology**
6 methods: DNA/Protein, UV, Lowry, BCA, CBB and Biuret.

Technical Parameters:

Model	BK-D560	BK-D580	BK-D590
Optical System	Double Beam, Grating 1200 lines/mm		
Wavelength Range	190~1100nm		
Spectral Bandwidth	1.8nm	1nm	0.5, 1, 2, 4, 5nm
Wavelength Accuracy	±0.3nm		
Wavelength Repeatability	≤0.2nm		
Photometric Accuracy	±0.002A (0~0.5Abs), ±0.004A (0.5~1.0Abs), ±0.3% T (0~100% T)		
Photometric Repeatability	0.001Abs (0~0.5Abs), 0.002Abs (0.5~1.0Abs), ≤0.2% T (0~100% T)		
Stray Light	≤0.04 T @ 360nm; 220nm		
Stability	±0.0003A/h @ 500nm		
Baseline Flatness	±0.0005A		
Noise	±0.0002Abs		
Display	65 thousand true color 7 inch TFT LCD(480 *800)		
Photometric Mode	T, A, C, E		
Photometric Range	0~200% T, -0.301~3.0A		
Detector	Silicon Photodiode		
Light Source	Deuterium Lamp, Tungsten Lamp		
Input	Membrane Keypad		
Output	USB-A*2 Print and data output USB-B Connect PC		
Standard Accessories	Scanning software, 1cm standard single slot cuvette holder, 1cm glass cuvette*4, 1cm quartz cuvette*2		
Optional Accessories	1cm standard single slot cuvette holder, long optical path cuvette holder, cuvette, micro cuvette, test tube type absorber rack, solid sample holder, deuterium lamp, tungsten lamp, quadruple cuvette holder, printer, four-slot water bath type constant temperature absorption pool, X-Y Adjustable Micro Absorption Pool, single bath type constant temperature absorption pool, program-controlled thermostatic absorption pool seat, 8 racks, reflection accessories		
Power Supply	AC110V/220±10%, 60/50Hz		
Package Size(W*D*H) mm	740*570*440		
Gross Weight(kg)	25		

UV/VIS Spectrophotometer Accessories

			
1cm standard single slot cuvette holder	Long optical path cuvette holder	Cuvette	Micro cuvette
			
Test tube type absorber rack	Solid sample holder	Deuterium lamp	Tungsten lamp
			
Quadruple cuvette holder	Printer	Four-slot water bath type constant temperature absorption pool	Reflection accessories
			
8 racks	X-Y Adjustable Micro Absorption Pool	Single bath type constant temperature absorption pool	Program-controlled thermostatic absorption pool seat

Flame Spectrophotometer

It is an analytical instrument based on emission spectrum principle, using the thermal energy of flame to make the certain element motivate luminescence to analyze the content of certain element in the material, widely used in the analysis and determination of agricultural fertilizer, soil, cement, ceramics and silicate industry and pathological studies of health care etc.

Features:

- * USB Interface(Except BK-FP640)
- * LPG as burning gas
- * Direct concentration read-out (Except BK-FP640)
- * Measuring range adjustable
- * 7 inch LCD touch screen
- * Automatic Calculation of correlation coefficient(Except BK-FP640)
- * Pre-selection of flame sizes
- * Flameout protection device
- * Optional built-in printer (Except for BK-FP640)



Air Compressor

Technical Parameters:

Model	BK-FP640	BK-FP6410	BK-FP6430	BK-FP6431	BK-FP6440	BK-FP6450
Sensitivity(LOD)	K	0.01ppm				
	Na	0.01ppm				
	Li	/	/	0.1ppm	/	0.1ppm
	Ca	/	/	/	2ppm	2ppm
Range	Ba	/	/	/	/	6ppm
	K	0~100ppm				
	Na	0~160ppm				
	Li	/	/	0~100ppm	/	0~100ppm
Linearity Error	Ca	/	/	/	0~1000ppm	0~1000ppm
	Ba	/	/	/	/	0-3000ppm
	K	≤0.195ppm				
	Na	≤0.69ppm				
Reproducibility	Li	/	/	≤0.15ppm	/	≤0.15ppm
	Ca	/	/	/	≤3ppm	≤3ppm
	Ba	/	/	/	/	≤9ppm
	3% CV for 7 consecutive samples					
Response Time	<8s					
Sample Uptake	<6ml/min					
Ambient Temp	10°C~35°C					
Humidity	≤85%					
Power Supply	AC110/220V±10%, 60/50Hz					
Consumption	250W					
Standard Accessory	Air compressor					
Package Size	570*560*400mm					
Gross weight	18kg					

Remark: The instrument data shows one digit after the decimal point by default.

Fluorescence Spectrophotometer

Applications:

Fluorescence analysis can provide information including excitation and emission spectrum, emission light intensity and measurement of life of emission light and polarization fluorescence etc and a wide lineal range of working curve.

This method has been used in: Medical science and clinical ,Pharmaceutical science and pharmacology,Biochemistry ,Food industry, Pollution and Organic and inorganic chemistry.



BK-F96PRO



BK-F93

Features for BK-F96PRO:

- * Two operation modes fluorescence intensity and luminous intensity.
- * 365nm exciting wavelength, Raman peak of water S/N ≥ 150 .
- * 10 stages emission spectrum scanning.
- * Support off-line mode and on-line mode.

Features for BK-F93 :

- * 1200 line diffraction grating emission monochromator.
- * LED is a cold-light source with longevity, lower background & reliability, prevent from thermo-pollution.
- * Automatic zero adjustment and automatic background subtraction.
- * Eight stage sensitivity adjustment, Real time fluorescence value display and concentration print out.,Extra wide dynamic range of fluorescence value ensures accurate measurement of minute changes in micro samples.

Technical Parameters:

Model	BK-F96PRO	BK-F93
Light Source	Hamamatsu 150W Xenon lamp	4 digits LED
Excitation filter	Interference optical filter a) Standard set is equipped with an interference optical filter of central wavelength at 365nm and 10nm bandwidth b) An optional interference optical filter of 25mm diameter of fixed wavelength select from range 250–700nm can be provided on users demand	LED options a) Standard set includes LED at wavelength 365nm b) The A set includes LED wavelength at 365nm, 376nm, 392nm, 405nm c) Customizable wavelength from 360nm to 600nm
Emission Monochromator	C-T diffraction grating (Em 200~900nm, bandwidth 10nm)	360~650nm (C-T diffraction grating)
Wavelength Accuracy	± 1 nm	± 2 nm
Wavelength Repeatability	≤ 0.5 nm	≤ 1 nm
Sensitivity	Raman peak of water in 1 cm quartz fluorescence cuvette with S/N ≥ 150	1*10 ⁻⁸ g/ml (Standard aqua of the sulfuric acid Quinine, 12nm bandwidth)
Linear Measurement(r)	≥ 0.995	
Stability	better than 1.5%/10min	better than 3%/10min
Response Time	(0.1~4)s, 6 stages adjustable	(0.1~4)s
Fluorescence Display Value	0.00~600.00	0.00~250.00
Standard Accessories	365nm filter(Preassembled), 1 pc F96PRO software package, 1 pc USB interface, 1 pc Quartz fluorescence sample cell10mm, 1 pair	RS232 serial port, Glass fluorescence cuvette 10mm 1 pair
Optional Accessories	Fuses(2A/5A), 200-700nm interference optical filter ($\phi 25$ mm) Quartz fluorescence sample cell10mm Multi-function fluorescent sample rack holder, Membrane sample rack, Powder sample rack, Sample cell jacket, Octave Filters 200uL microcentrifuge tube accessory Upconversion fluorescent accessory	Data processing software package (pack, for PC) Fuses(2A) Quartz fluorescence cuvette10mm Optional LED A Set includes: 365nm, 376nm, 392nm, 405nm
Power Supply	AC110/220V $\pm 10\%$, 60/50Hz	
Package Size(W*D*H)mm	535*500*380	450* 420 *280
Gross Weight(kg)	14	9

BK-AA4530F Atomic Absorption Spectrophotometer



Standard Accessories:



Oil free air compressor



Printer

Features:

- * Completely controlled by PC, can flexibly select the flame and graphite furnace atomizer (optional).
- * Integrated floated optical platform design improves the optical system shock resistance stable.
- * Eight light stands can be changed automatically and preheat the eight lights meantime as well as optimize the working condition of the hollow cathode lamp.
- * Position adjusting: the flame burner can be set on the best position automatically.
- * Fully automated wavelength scanning and peak searching.
- * Complete safety chains protection equipment: warning and automatic safety protection for the wrong burner connection, leakage of the gas, under voltage of air and the abnormal flameout.
- * Deuterium lamp and self-absorption background calibration.
- * Measuring method: flame absorption method and emission method.
- * Result printing: parameter, data result and diagram.
- * Data processing: more than 500 data self-storage and cut-off storage, the analyzed result is stored in EXCEL format.

Technical Parameters:

Model	BK-AA4530F
Wavelength Range	190~900nm
Spectral Bandwidth	0.1, 0.2, 0.4, 1.0 and 2.0nm
Wavelength Accuracy	±0.15nm
Wavelength Repeatability	±0.04nm
Base Line Stability	±0.002A/30min (Cu)
Characteristic Concentration	0.02µg/ml/1% (Cu)
Detection Limit	0.004µg/ml (Cu)
Preciseness	±0.5%
Grating	1800 lines/mm
Inflamer	All-metal titanium burner
Atomizer	Effective glass atomizer
Lamp Stand	8
D2 background Calibration	When the background is 1 A, the background ability should be deducted not less than 50 times; self absorption background deduction method
Power Supply	220V, 50Hz
Packing Size(W*D*H) mm	860*705*755 (Main instrument); 545*445*1385 (Accessories)
Gross Weight(kg)	105 (Main instrument); 100 (Accessories)
Standard Accessories	Software; Inkjet printer; Oil free Air compressor; Acetylene reducing valve; Cu Hollow cathode lamp; Air filter
Optional Accessories	Graphite Furnace 4510GF; Hollow cathode lamp(Ag, Au, Ca, Cd, Cr, Fe, Hg, K, Au, Mg, Mn, Na, Ni, Pb, Zn, Sb, etc), Graphite tubes, Recirculating cooling water system, Hydride generator, Autosampler

Flame System:

Acetylene Air Burner	100mm
Ignition Dynamic Baseline Drift	≤0.006A/30min
Characteristic Concentration	≤0.025µg/ml/1%(Cu)
Related Standard Deviation of the Accuracy	±0.5%(Cu, absorbance>0.8A) (detection limit Cu≤0.008µg/ml)
Safety System	Can automatically cut off the gas when the pressure is not enough, the power is off, flameout and unconformity of the burner.

Graphite Furnace(Optional):

Max. Temperature	3000°C
Max Heating Speed	≥2000°C/S
Characteristic Quantity	Cd≤0.5*10 ⁻¹² g Cu≤0.5*10 ⁻¹¹ g
Accuracy	Cu≤3% Cd≤3%
Safety System	Over current protection Low air pressure alarm/protection; Low cooling water flow alarm/protection
Power Supply	220V, 50Hz
Consumption	7000W
Packing Size(W*D*H) mm	740*640*700
Gross Weight(kg)	90

BK-AA320N Atomic Absorption Spectrophotometer



Oil free air compressor
(standard accessories)

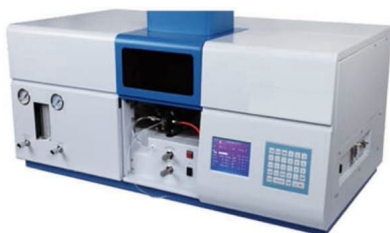

Features:

- * Build-in computer data processing and LCD display.
- * **Stability:** Double-beam system can automatically compensate the light source drift and wavelength drift caused by the variation of temperature and electronic circuit drift.
- * **Quickly:** The cathode lamp does not need to be pre-heated for long time and sample can be analyzed immediately.
- * **High precision of measurement:** Gas path system is equipped with precision pressure stabilizing and current stabilizing devices to reach stable flame and low noise. Specially designed fine light beam passes through the flame to ensure a high precision analytical test and low characteristic concentration.
- * **High energy optical path.**
- * **Long-life and anti-corrosive atomization system.**
- * **Multi-functional analysis mode:** ① flame absorption, ② flame emission, ③ graphite furnace atomic absorption, ④ hydride generation.
- * **Safe and reliable gas path system:** Special devices of quick gas conversion and safety protection can be used to analyze air-acetylene flame and extend the analytic elements to reach more than 60.

Technical Parameters:

Model	BK-AA320N
Wavelength Range	190~900nm
Wavelength Accuracy	±0.5nm
Wavelength Repeatability	±0.3nm (single direction)
Spectral Bandwidth	0.2nm, 0.4nm, 0.7nm, 1.4nm, 2.4nm, 5.0nm
Grating	1800 lines/mm
Resolution	<40%
Base Line Stability	±0.004Abs/30min
Characteristic Concentration	≤0.04μg/ml/1% (Cu)
Detection Limit	≤0.008μg/ml (Cu)
Background Calibration	>30 times
Power Supply	220V, 50Hz
Package Size(W*D*H)	1250*795*765mm (Main instrument), 545*445*1385mm (Accessories)
Gross Weight	138kg (Main instrument), 56kg (Accessories)
Standard Accessories	RS232 serial port, Oil-free air compressor, Glass Atomizer, Cu Hollow cathode lamp, Atomizer unit Burner unit Dust cover, Water-separating gas filter, Titanium burner-10cm
Optional Accessories	Software, Model GA3202 HGA graphite furnace system, Hydride generator, Graphite tubes, Recirculating cooling water system, Hollow cathode lamp(Ag, Au, Ca, Cd, Cr, Fe, Hg, K, Mg, Mn, Na, Ni, Pb, Zn, AS, etc)

NIR Spectrophotometer

NIR spectrophotometer, mainly used for liquid samples qualitative and quantitative analysis, applies to gasoline, drinks, milk and other areas of nutrients, water chemistry and other physical properties of the rapid non-destructive analysis determination.

The instrument monitors the ambient temperature and humidity in real time and stores it in the spectrum file, which is convenient for users to check and optimize the measurement conditions.



Features:

- * Single-channel whole spectrum scanning.
- * Built-in high-quality PTFE reference module and polystyrene wavelength standard filter.
- * Automatic reference calibration and monitoring wavelength.

Technical Parameters:

Model	BK-S430
Optical System	Grating monochromator
Bandwidth	8nm
Wavelength Range	900~2500nm
Wavelength Accuracy	±0.2nm
Wavelength Reproducibility	±0.05 nm
Stray Light	≤0.1%
Scanning Time	1 minute or adjustable
Noise	≤0.0005 Abs
Interface	USB
Standard Accessories	2*1cm quartz square sample cell , 2*1mm quartz micro sample cell
Optional Accessories	Laptop
Power Supply	110~240V, 50Hz/60Hz
Packing Size	535*500*380mm
Gross Weight	12kg

Rotary Evaporator



Introduction:

The rotary evaporator is made according to the principle of constant temperature heating and film evaporation under vacuum and negative pressure. The rotary evaporator uses stepless speed regulation to make the glass rotating bottle rotate at a constant speed, and the materials form a large area uniform film on the bottle wall.

Then, the rotating bottle is evenly heated by the intelligent constant temperature water bath, evaporated at a high speed under vacuum, and the solvent vapor is cooled by the high-efficiency glass condenser and recycled in the collection bottle.

Application:

Mainly used for concentration, crystallization, drying, separation and solvent recovery in pharmaceutical, chemical and biopharmaceutical industries.

Features:

- * Stepless speed controller
- * PID temperature adjustment
- * Automatic lift control
- * High evaporating and recovery collecting rate

Technical Parameters:

Model	BK-RE-1A
Rotary Bottle	1 L24#(standard size)
Collecting Bottle	0.5L 24 # (standard size)
Glass Material	GG-17
Shelf Material	Spray anti-corrosion steel
Heating Unit Size	250*388*169mm
Chamber Size	φ220*140 mm
Heating Power	1KW
Temp. Range	0-99°C
Temp. Accuracy	±1°C
Temp. Sensor	PT100
Vacuum	0.096Mpa
Rotary Motor	30W
Rotating Speed	0-120rpm
Lift	Motor
Lifting Power	15W
Lifting Stroke	150mm
Speed Control	Stepless speed controller
Sealing Method	Fluorine rubber skeleton oil seal
Condenser	φ85*450mm
Charging Valve	19#(standard size)
Power Supply	220V,50Hz(Standard); 220V,60Hz(Optional)
External Size(W*D*H)	640*340*(860-1010)mm
Package Size(W*D*H)	740*550*580mm
Gross Weight	38kg
Standard Accessory	1 L Rotary Bottle*1, 0.5 L Collecting Bottle*1
Optional Accessory	Vacuum pump, Recirculating chiller, Transparent cover

Rotary Evaporator

Features:

- * Double sealing rings with Teflon and Viton makes vacuum up to -0.098Mpa.
- * Intelligent temperature control and digital temperature display.
- * High evaporating and recovery collecting rate.
- * Overloading protect function.
- * Expandable module design.
- * Stepless speed controller.



Technical Parameters:

Model	RE-2010
Rotary Bottle	1L 24# (standard size)
Collecting Bottle	1L 35# (ball mill mouth)
Condenser	Vertical $\phi 80 \times 370$ mm
Charging Valve	19# (standard size)
Rotating Speed	0~200rpm
Vacuum	-0.098Mpa
Temp. Range	RT~99°C
Temp. Accuracy	$\pm 1^\circ\text{C}$
Stroke Height	100mm+150mm(sliding + manual)
Rotary Motor	40W
Heating Power	1.3KW
Water Evaporating Speed	20ml/min
Vacuum Sealing	Double sealing rings made of Teflon+ Viton materials
Shelf Material	Aluminum alloy
Chamber Material	Aluminum alloy +Teflon $\phi 240 \times 140$ mm
Power Supply	AC220/110 V $\pm 10\%$, 50/60 Hz
External Size(W*D*H)	570*400*630~880mm
Package Size(W*D*H)	710*510*400mm
Gross Weight	15.5Kg
Standard Accessory	1L Rotary Bottle*1, 1L Collecting Bottle*1
Optional Accessory	Vacuum pump, Recirculating chiller

Patented condenser with cooling surface 1700cm²

Chemical-resistant double PTFE sealing

Large digital LCD screen displays heating temperature rotation speed and timing



Motorized lifting for quick and safe operation

Large 5L water-oil heating bath

Designed a detachable operating panel allows remote control

Features:

- * Evaporating flask with an ejector, convenient to remove.
- * 5L water and oil bath dual-purpose heating pot, heating temperature can reach 180°C, easy to switch between water and oil bath heating modes.
- * Patented technology condenser, high recovery rate, condensing effect Outstanding.

Technical Parameters:

Model	RE 100-Pro
Item No.	6010110111
Evaporating Flask	1L(NS 29/32, 18300120)
Receiving Flask	1L(KS 35/20, 18300110)
Display	LCD
Rotating Speed	20~280rpm
Temp. Range	RT~180°C
Temp. Accuracy	Water bath: $\pm 1^\circ\text{C}$; Oil bath: $\pm 3^\circ\text{C}$
Lift	Motor
Stroke Height	150mm
Timing Range	1~999min
Motor	DC brushless motor
Heating Power	1300 W
Stroke Displacement	Automatic 150mm
Protection Class	IP20
Rotation	Reversible Direction
Interface	USB
Power	1400W
Power Supply	AC110/220V $\pm 10\%$, 50/60Hz(Customizable)
External Size(W*D*H)	465*457*583 mm
Package Size(W*D*H)	640*1100*650mm
Net Weight	15kg
Gross Weight	36kg
Standard Accessory	Condenser(1700cm ²)*1, 1L Evaporating flask*1, 1L Receiving flask*1, 5L pot*1
Optional Accessory	Vacuum pump, Recirculating chiller



CCP5-Mini Recirculating chiller (6032200220)



Flow Rate:	
mbar	L/min
1000	25
880	22
750	20
600	12
480	7.5
280	5

C410 Vacuum pump(18900389)
Specifications:
Maximum Vacuum:13mbar
Work Mode: Continuous Operation
Nozzle Size:8mm
Power: 95W
Motor speed:1450rpm

Explosion-proof Rotary Evaporator

Features:

- * LED display.
- * Explosion-proof motor.
- * Explosion frequency inverter.
- * Explosion auto temperature controller.
- * Stepless speed controller.
- * Auto-lifting bath is optional
- * Stainless steel and aluminium alloy structure
- * Anti-corrosive PTFE sealing good performance.



Technical Parameters:

Model	ExRE-1002	ExRE-2002	ExRE-5003
Rotary Bottle	10L (flange Ø95)	20L (flange Ø95)	50L (flange Ø125)
Collecting Bottle	5L (flange φ60-50)	10L (flange φ60-50)	20L (flange φ60-50)
Condenser	Vertical three backflow , φ120*620mm(main), φ135*475mm(SUB)	Vertical three backflow , φ130*700mm(main), φ160*530mm(SUB)	Vertical three backflow, φ160*835mm(main), φ160*530mm(SUB)
Charging Valve	34# (standard size)		40# (standard size)
Rotating Speed	0~120 rpm		
Vacuum	-0.095 Mpa		
Temp. Range	RT~180°C		
Temp. Accuracy	±1°C		
Rotating Power	120W		180W
Heating Power	3KW	5KW	8KW
Power Supply	AC220/110V±10%, 50/60 Hz	AC220V±10%, 50/60 Hz	AC220V±10%, 50 Hz or 380V, 50Hz
External Size(W*D*H)	930*560*1910 mm	1000*600*2130 mm	1330*730*2340 mm
Package Size(W*D*H)	1320*780*755 mm	1350*670*720mm 680*680*790 mm	1420*820*720 mm 830*730*910 mm
Gross Weight	116kg	143kg	195kg
Standard Accessory	10L rotary bottle*1, 5L collecting bottle*1,	20L rotary bottle*1, 10L collecting bottle*1	50L rotary bottle*1, 20L collecting bottle*1
Optional Accessory	Explosion-proof transducer, Explosion-proof motor EX120W Double collection bottle, Auto-lifting, Vacuum pump, Recirculating chiller		

Small Capacity Rotary Evaporator



Features:

- * Intelligent temperature control and digital temperature display.
- * Stepless speed controller.
- * Teflon Sealing and host automatically

Technical Parameters:

Model	RE-2000A	RE-2000B	RE-2000E	RE-52A	RE-52C	RE-5299
Rotary Bottle	1L 24# (standard size)					
Collecting Bottle	1L 35# (ball mill mouth)			0.5L 24# (standard size)		
Condenser	Vertical φ85*430mm,			Vertical φ85*450mm, 29#(standard size)		
Charging Valve	19# (standard size)			19# (standard size)		
Rotating Speed	0~200rpm			0~120rpm		
Vacuum	-0.098Mpa					
Temp. Range	RT~99°C					
Temp. Accuracy	±1°C					
Stroke Height	120mm			150mm		
Rotating Power	40W			30W		
Heating Power	1.5KW			1KW		
Shelf Material	Aluminum alloy			Powder coating anticorrosive		
Chamber Material	Teflon φ235*145mm			SS φ220*120mm		SS φ245*140mm
Power Supply	AC220/110V±10%, 50/60Hz					
External Size(W*D*H)	630*400*690-810mm			640*430*860-1010mm		660*440*880-1030 mm
Package Size(W*D*H)	620*620*490mm			600*460*470mm		
Gross Weight	25kg		23kg	19kg	20kg	20kg
Standard Accessory	1000ml rotary bottle*1, 500ml recycling bottle*1					
Optional Accessory	RT~400°C oil bath, 304 SS bath, Transparent bath cover, Vacuum pump, Recirculating chiller			RT~400°C oil bath, Transparent bath cover, Vacuum pump, Recirculating chiller		

Rotary Evaporator



Features:

- * Electronic stepless speed control. * LED display
- * Optional explosion-proof function (eg. RE-301, RE-501, RE-1002, RE-3002, RE-5003)

Technical Parameters:

Model	RE-201D	RE-301	RE-501	RE-1002	RE-2002	RE-5003
Rotary Bottle	1L 24#standard mouth	3L flange Ø50	5L flange Ø50	10L flange Ø95	20L flange Ø95	50L flange Ø125
Collecting Bottle	1L 35# (ball mill mouth)	2L 35# (ball mill mouth)	3L 35# (ball mill mouth)	5L (flange φ60-50)	10L flange Ø60	20L (flange φ60-50)
Condenser	Vertical φ85*430mm,35# (ball mill mouth)	Vertical φ100*530mm	Vertical φ100*530mm	Vertical three backflow φ120*620mm (main), φ135*475mm (SUB)	Vertical three backflow φ130*700mm (main), φ160*530mm (SUB)	Vertical three backflow φ160*835mm (main), φ160*530mm (SUB)
Charging Valve	19# (standard size)			34# (standard size)		40# (standard size)
Rotary Speed	0~120rpm					
Vacuum	0.098Mpa			0.095 Mpa		
Temp. Range	RT~180°C					
Temp. Accuracy	±1°C					
Stroke Height	200mm			180mm		
Rotary Power	40W	40W		120W		180W
Heating Power	1KW	2KW		3KW	5KW	8KW
Shelf Material	Stainless steel			Coating anticorrosive		
Chamber Material	SS 245*140mm	SS 265*160mm	SS 280*170mm	SS 350*220mm	SS 450*260mm	SS 550*320mm
Plate Size	280*330mm	350*330mm		534*504mm	474*474mm	550*320mm
Power Supply	AC220V/110V±10%,50/60Hz			AC220V±10%,50/60Hz		AC380V/220V±10%,50Hz
External Size(mm)	700*330*785	740*330*970	760*330*1030	930*560*1910	1000*600*2130	1330*730*2340
Package Size(mm)	600*460*470	990*620*470		1320*780*755	1350*670*720 680*680*790	1420*820*720 830*730*910
Gross Weight	21kg	40kg	42kg	107kg	136kg	186kg
Standard Accessory	1L Rotary bottle*1; 1L Collecting bottle*1	3L Rotary bottle*1; 2L Collecting bottle*1	5L Rotary bottle*1; 3L Collecting bottle*1	10L Rotary bottle*1; 5L Collecting bottle*1	20L Rotary bottle*1; 10L Collecting bottle*1	50L Rotary bottle*1; 20L Collecting bottle*1
Optional Accessory	Transparent bath cover, Explosion-proof transducer	Explosion-proof transducer, Explosion-proof motor EX40W		Explosion-proof transducer, Double collection bottle, Auto-lifting, Explosion-proof motor EX120W		
	Vacuum pump, Recirculating chiller					

Water Circulating Vacuum Pump



Technical Parameters:

Model	SHZ-DIII (Four gauge four pumping)	SHZ-95B
Pump Head	4	5
Speed of Evacuation	10L/Min	
Vacuum	-0.098Mpa	\
Circulating Pump Flow	40L/min	80L/min
Pump Lift	12m	
Material	Anti-corrosion	Anti-corrosion or Stainless Steel
Consumption	370W	370W
Capacity	15L	50L
Power Supply	AC220/110V±10%, 50/60Hz	
Package Size(W*D*H)	430*330*510mm	520*430*900mm
Gross Weight	12kg	30kg
Applicable Rotary Evaporator Model	RE-2010, RE 100-Pro, RE-2000A, RE-2000B, RE-2000E, RE-52A, RE-52C, RE-5299, RE-201D, RE-301, RE-501	ExRE-1002, ExRE-2002, ExRE-5003, RE-1002, RE-2002, RE-5003

Note: Vacuum pump does not have the function of adjusting vacuum degree, if you need this function you should be match the vacuum control instrument.

Chiller

Recirculating Chiller



CCA-420



DLSB Series

Principle:

This product is mechanically cooled by a fully closed compressor. The inner wall of the cooling tank has a cooling copper coil. The refrigerant (Freon) circulates continuously through the coil of the inner wall of the tank to cool the refrigerant in the tank, and the refrigerant is transported to the sandwich or condensing coil of the supporting equipment through the built-in circulation pump and external circulation pipeline. Indirectly cooling the materials in the reactor, cooling and liquefaction of the condensing pipe contact steam.

This product can generally be connected to the sandwich of the double layer reaction kettle, the rotary evaporator, the condensing coil of the reaction kettle, and can also be used to put the object or container to be cooled directly into the bath for reaction.

From the lower outlet pipeline of the product is connected to the lower inlet pipeline of the kettle body or condenser, and the circulating liquid comes out from the upper circulation port and returns to the inlet of the product through the pipeline, forming a complete circulation space.

Features:

- * Famous manufacturers of original closed compressor, advanced performance, reliable quality.
- * Professional relays, protectors, capacitors, etc., are well-known brands of high-quality equipment to ensure reliability and service life.
- * Digital display temperature control, simple operation, eye-catching.
- * A variety of functions, can provide low temperature quality cooling water, low temperature unfrozen liquid, small low temperature water bath.
- * Can be combined with circulating water type multi-purpose vacuum pump, vacuum freeze-drying oven, rotary evaporator, magnetic stirrer and other instruments, suitable for multi-functional low temperature conditions of chemical reactions, drug storage.
- * It can be matched with a variety of large precision equipment to overcome the difficulty of expensive instruments and equipment that can not be used because of bad cooling water, high temperature and unstable water pressure.

Technical Parameters:

Model	CCA-420	DLSB-5/20	DLSB-20/40
Temp. Display	LCD display		
Tank Volume	4L	6.8L	21L
Matching Reaction Kettle(Steam)	1~2L	1~5L	20L
Tank Material	304 Stainless Steel	201 Stainless Steel	
Tank Size	220*155*120mm	Φ220*180mm	Φ300*300mm
Temp. Control Accuracy	±0.1°C		
Display Temp. Resolution	0.1°C		
Pump Lift	1.5~2.7m	4~6m	
Circulating Pump Flow	8~16L/min	20~40L/min	
Refrigerant	R134A	R290	R404A
Refrigerating Capacity	450~260W	2324W	6972W
Pressure	≤0.4Mpa		
Ambient Relative Humidity	70%, Ventilation		
Instrument Temp. Control Range	-20°C~RT		-40°C~RT
Optimum Ambient Temp.	5~35°C		
Unload Min Temp.	-20°C	-20°C	-42°C
Circulation Pump Power	10W	100W	
Circulating Pump	Magnetic pump	Fully-closed & No-leaked special pump	
Circulating Water Mouth Interface	Outer diameter 12 mm		Outer diameter 16 mm
Sensor	PT100		
Coil Diameter	\	Φ185mm	Φ250mm
Opening Size	\	Φ200mm	Φ250mm
Power Supply	AC220V±10%, 50/60Hz	AC220±10%, 50/60Hz; AC110±10%, 60Hz	AC220V±10%, 50/60Hz
Secure Protection	Overload protection, Overheating protection, Refrigerator delay protector	Leakage, overload circuit breaker, Overload relay circuit, Refrigerator protection timer, Circulating pump thermal protector, Refrigerator high-pressure pressure switch, Temperature control self-diagnosis function	
External Size(W*D*H)mm	520*250*560	485*423*(760+400)	590*670*(975+500)
Package Size(W*D*H)mm	580*300*570	570*460*790	720*590*1140
Gross Weight(kg)	30	50	133
Accessories	In and out joint *1, silicone pipe insulation*2	In and out joint *1, Vertical rod*1, Thermal insulation pipe*2	
Applicable Rotary Evaporator Model	RE-2010, RE-2000A, RE-2000B, RE-2000E, RE-52A, RE-52C, RE-5299, RE-201D, RE 100-Pro	RE-301, RE-501	RE-1002, ExRE-1002, RE-2002

Pipettes

Micro Pipette

Application:

Mechanical Pipette is suitable for pharmaceutical R&D centers, school laboratories, pharmaceutical and chemical R&D companies, chemical synthesis and other places.

Features:

- * Light weight and ergonomic design to ensure a better sense of use.
- * Digital display, easy to read data.
- * The pipettes cover volume range of 0.5µl to 1ml.
- * Easy to calibrate and maintain.
- * The low part can be autoclaved without affecting performance and comfort.
- * Manufactured from innovative materials.



Technical Parameters:

Volume	Increment	Test Volume(µl)	Maximum Permissible Systematic Error		Maximum Permissible Random Error	
			%	µl	%	µl
0.1-2.5µl	0.05µl	0.25	6	0.015	3	0.0075
		1.25	1.5	0.0188	1.8	0.0225
		2.5	0.4	0.01	1.2	0.03
0.5-10µl	0.1µl	1	1.0	0.01	1.8	0.018
		5	0.4	0.02	0.4	0.02
		10	0.5	0.05	1.1	0.11
2-20µl	0.5µl	2	0.4	0.008	0.4	0.008
		10	0.4	0.04	0.5	0.05
		20	0.5	0.1	0.4	0.08
5-50µl	0.5µl	5	2	0.1	1.1	0.055
		25	1.3	0.325	0.7	0.175
		50	0.6	0.3	1.5	0.75
10-100µl	1µl	10	0.2	0.02	0.9	0.09
		50	0.2	0.1	0.9	0.45
		100	0.3	0.3	0.9	0.9
20-200µl	1µl	20	0.5	0.1	0.8	0.16
		100	0.3	0.3	0.2	0.2
		200	0.3	0.6	0.1	0.2
50-200µl	1µl	50	0.2	0.1	0.8	0.4
		100	0.3	0.3	0.2	0.2
		200	0.3	0.6	0.1	0.2
100-1000µl	5µl	100	0.3	0.3	0.1	0.1
		500	0.3	1.5	0.1	0.5
		1000	0.3	3	0.1	1
200-1000µl	5µl	200	0.3	0.6	0.1	0.2
		500	0.3	1.5	0.1	0.5
		1000	0.3	3	0.1	1
1000-5000µl	50µl	1000	0.3	3	0.1	1
		2500	0.3	7.5	0.1	2.5
		5000	0.3	15	0.1	5
2-10ml	0.1ml	2000	0.4	8	0.1	2
		5000	0.4	20	0.1	5
		10000	0.4	40	0.1	10

Micro Pipette Pro

Application:

Micro Pipette is suitable for pharmaceutical R&D centers, school laboratories, pharmaceutical and chemical R&D companies, chemical synthesis and other places. It is often used in the laboratory to pipette a small amount of liquid or a small amount of liquid. The specifications are different, and the pipette tips of different specifications are matched with different sizes of pipette tips.

Features:

- * The pipettes are autoclavable in their entirety without compromising performance or comfort.
- * Light weight and ergonomic design to ensure a better sense of use.
- * The pipettes cover volume range of 0.5µl to 1ml.
- * The interior of the product has good air tightness, stable and accurate, and no liquid leakage.
- * Easy to calibrate and maintain.
- * Digital display, easy to read data.



Technical Parameters:

Volume	Increment	Test Volume(µl)	Maximum Permissible Systematic Error		Maximum Permissible Random Error	
			%	µl	%	µl
0.1-2.5µl	0.05µl	0.25	6	0.015	3	0.0075
		1.25	1.5	0.0188	1.8	0.0225
		2.5	0.4	0.01	1.2	0.03
0.5-10µl	0.1µl	1	1.0	0.01	1.8	0.018
		5	0.4	0.02	0.4	0.02
		10	0.5	0.05	1.1	0.11
2-20µl	0.5µl	2	0.4	0.008	0.4	0.008
		10	0.4	0.04	0.5	0.05
		20	0.5	0.1	0.4	0.08
5-50µl	0.5µl	5	2	0.1	1.1	0.055
		25	1.3	0.325	0.7	0.175
		50	0.6	0.3	1.5	0.75
10-100µl	1µl	10	0.2	0.02	0.9	0.09
		50	0.2	0.1	0.9	0.45
		100	0.3	0.3	0.9	0.9
20-200µl	1µl	20	0.5	0.1	0.8	0.16
		100	0.3	0.3	0.2	0.2
		200	0.3	0.6	0.1	0.2
50-200µl	1µl	50	0.2	0.1	0.8	0.4
		100	0.3	0.3	0.2	0.2
		200	0.3	0.6	0.1	0.2
100-1000µl	5µl	100	0.3	0.3	0.1	0.1
		500	0.3	1.5	0.1	0.5
		1000	0.3	3	0.1	1
200-1000µl	5µl	200	0.3	0.6	0.1	0.2
		500	0.3	1.5	0.1	0.5
		1000	0.3	3	0.1	1
1000-5000µl	50µl	1000	0.3	3	0.1	1
		2500	0.3	7.5	0.1	2.5
		5000	0.3	15	0.1	5
2-10ml	0.1ml	2000	0.4	8	0.1	2
		5000	0.4	20	0.1	5
		10000	0.4	40	0.1	10

8-Channel Pipette



Introduction:

The 8-channel pipette is a measuring tool that moves liquid from the original container to another container within a certain measuring range. The unit is microliter(μl). It is characterized by precision and convenience, and is widely used in biological and chemical fields. It is often used for the removal of a small amount or trace liquid in the laboratory.

Different specifications of pipettes are matched with different sizes of pipette tips.

Application:

School laboratory, chemical synthesis, pharmaceutical research and development center, pharmaceutical research and development company.

Features:

- * Precise liquid separation, calibrated according to EN/ISO8655 standard.
- * Digital window, easy to set the range, at a glance.
- * Ergonomic, light and convenient, comfortable grip.
- * Can be autoclave, and will not affect the performance and comfort.

Technical Parameters:

Item No.	Volume Range	Increment	Test Volume(μl)	Maximum Permissible Systematic Error	Maximum Permissible Random Error		
7010103004	0.5-10 μl 8-channel	0.1 μl	1	1.0%	0.01 μl	1.8%	0.018 μl
			5	0.4%	0.02 μl	0.4%	0.02 μl
			10	0.5%	0.05 μl	1.1%	0.11 μl
7010103006	5-50 μl 8-channel	0.5 μl	5	2%	0.1 μl	1.1%	0.055 μl
			25	1.3%	0.325 μl	0.7%	0.175 μl
			50	0.6%	0.3 μl	1.5%	0.75 μl
7010103012	50-300 μl 8-channel	5 μl	50	0.2%	0.1 μl	0.8%	0.4 μl
			150	0.3%	0.3 μl	0.2%	0.2 μl
			300	0.3%	0.6 μl	0.1%	0.2 μl

TopPette-Mechanical Pipettes



Features for TopPette:

- * Light weight, ergonomic, low force design
- * Digital display clearly reads volume setting
- * The pipettes cover volume range of 0.1 μl to 10ml
- * Easy to calibrate and maintain
- * The lower part is autoclavable
- * Design helps avoid repetitive strain injuries

Features for Multi-channel TopPette:

- * 8 and 12 channel pipettes are available for standard 96-well plate
- * Dispensing head rotates ensures optimum pipetting convenience
- * Individual piston/tip cone assemblies allow easy repair and maintenance
- * Compound material tip cone design allows visual seal verification
- * Universal pipette tips can be used

MicroPette Plus Autoclavable Pipette

Fully Autoclavable:

The MicroPette plus pipettes can be fully autoclaved at 121°C, 1 atm for less than 20 mins. The pipettes can be autoclaved without special preparations. After autoclaving the pipette must be cooled down and dried over 12 hours.

Features for MicroPette plus:

- * Fully autoclavable
- * Light weight, ergonomic, low force design
- * Digital display clearly reads volume setting
- * The pipettes cover volume range of 0.1 μl to 10ml
- * Easy to calibrate and maintain
- * Design helps avoid repetitive strain injuries
- * Manufactured from innovative materials

Features for multi-channel MicroPette plus:

- * 8 and 12 channel pipettes are available for standard 96-well plate
- * Individual piston and tip cone assemblies allow easy repair and maintenance
- * Compound material tip cone design allows visual seal verification
- * Universal pipette tips can be used
- * Dispensing head rotates for optimum pipetting convenience

Note: It is recommended to check the performance of the pipette after each autoclaving. It is also recommended to grease the piston and seal of the pipette after each 10 autoclaving.



Technical Parameters:

TopPette Mechanical Pipettes / MicroPette Plus Autoclavable Pipettes (Adjustable and Fixed Volume)

Single-channel Adjustable Volume Pipettes						
Volume Range	Increment	Test Volume(μl)	Maximum Permissible Systematic Error		Maximum Permissible Random Error	
0.1-2.5μl	0.05μl	2.5	2.50%	0.0625μl	2.00%	0.05μl
		1.25	3.00%	0.0375μl	3.00%	0.0375μl
		0.25	12.00%	0.03μl	6.00%	0.015μl
0.5-10μl	0.1μl	10	1.00%	0.1μl	0.80%	0.08μl
		5	1.50%	0.075μl	1.50%	0.075μl
		1	2.50%	0.025μl	1.50%	0.015μl
2-20μl	0.5μl	20	0.90%	0.18μl	0.40%	0.08μl
		10	1.20%	0.12μl	1.00%	0.1μl
		2	3.00%	0.06μl	2.00%	0.04μl
5-50μl	0.5μl	50	0.60%	0.3μl	0.30%	0.15μl
		25	0.90%	0.225μl	0.60%	0.15μl
		5	2.00%	0.1μl	2.00%	0.1μl
10-100μl	1μl	100	0.80%	0.8μl	0.15%	0.15μl
		50	1.00%	0.5μl	0.40%	0.2μl
		10	3.00%	0.3μl	1.50%	0.15μl
20-200μl	1μl	200	0.60%	1.2μl	0.15%	0.3μl
		100	0.80%	0.8μl	0.30%	0.3μl
		20	3.00%	0.6μl	1.00%	0.2μl
50-200μl	1μl	200	0.60%	1.2μl	0.15%	0.3μl
		100	0.80%	0.8μl	0.30%	0.3μl
		50	1.00%	0.5μl	0.40%	0.2μl
100-1000μl	5μl	1000	0.60%	6μl	0.20%	2μl
		500	0.70%	3.5μl	0.25%	1.25μl
		100	2.00%	2μl	0.70%	0.7μl
200-1000μl	5μl	1000	0.60%	6μl	0.20%	2μl
		500	0.70%	3.5μl	0.25%	1.25μl
		200	0.90%	1.8μl	0.30%	0.6μl
500-5000μl	50μl	5000	0.50%	25μl	0.15%	7.5μl
		2500	0.60%	15μl	0.30%	7.5μl
		1000	0.70%	7μl	0.30%	3μl
1-10ml	0.1ml	10ml	0.60%	60μl	0.20%	20μl
		5ml	1.20%	60μl	0.30%	15μl
		2ml	3.00%	60μl	0.60%	12μl

Note: 1~10ml is not available for micropette plus autoclaveable pipettes.

8-channel Adjustable Volume Pipettes						
Volume Range	Increment	Test Volume(μl)	Maximum Permissible Systematic Error		Maximum Permissible Random Error	
0.5-10μl	0.1μl	10	1.50%	0.15μl	1.50%	0.15μl
		5	2.50%	0.125μl	2.50%	0.125μl
		1	4.00%	0.04μl	4.00%	0.04μl
5-50μl	0.5μl	50	1.00%	0.5μl	0.50%	0.25μl
		25	1.50%	0.375μl	1.00%	0.25μl
		5	3.00%	0.15μl	2.00%	0.1μl
50-300μl	5μl	300	0.70%	2.1μl	0.25%	0.75μl
		150	1.00%	1.5μl	0.50%	0.75μl
		50	1.50%	0.75μl	0.80%	0.4μl

12-channel Adjustable Volume Pipettes						
Volume Range	Increment	Test Volume(μl)	Maximum Permissible Systematic Error		Maximum Permissible Random Error	
0.5-10μl	0.1μl	10	1.50%	0.15μl	1.50%	0.15μl
		5	2.50%	0.125μl	2.50%	0.125μl
		1	4.00%	0.04μl	4.00%	0.04μl
5-50μl	0.5μl	50	1.00%	0.5μl	0.50%	0.25μl
		25	1.50%	0.375μl	1.00%	0.25μl
		5	3.00%	0.15μl	2.00%	0.1μl
50-300μl	5μl	300	0.70%	2.1μl	0.25%	0.75μl
		150	1.00%	1.5μl	0.50%	0.75μl
		50	1.50%	0.75μl	0.80%	0.4μl

Fixed Volume Pipettes						
Volume Range	Increment	Test Volume(μl)	Maximum Permissible Systematic Error		Maximum Permissible Random Error	
5μl	/	5μl	1.3%	0.065μl	1.2%	0.06μl
10μl	/	10μl	0.8%	0.08μl	0.8%	0.08μl
20μl	/	20μl	0.6%	0.12μl	0.5%	0.1μl
25μl	/	25μl	0.5%	0.125μl	0.3%	0.075μl
50μl	/	50μl	0.5%	0.25μl	0.3%	0.15μl
100μl	/	100μl	0.5%	0.5μl	0.3%	0.3μl
200μl	/	200μl	0.4%	0.8μl	0.2%	0.4μl
250μl	/	250μl	0.4%	1.0μl	0.2%	0.5μl
500μl	/	500μl	0.3%	1.5μl	0.2%	1.0μl
1000μl	/	1000μl	0.3%	3.0μl	0.2%	2.0μl
2000μl	/	2000μl	0.3%	6.0μl	0.15%	3.0μl
5000μl	/	5000μl	0.3%	15μl	0.15%	7.5μl

Levo Plus Pipette Filler

Features:

- * Volume range of 0.1-100ml
- * One-handed operation
- * Light weight, ergonomic design
- * Efficient lithium-ion battery offers long runtime on each charge
- * Low battery alarm
- * Powerful motor fills a 25ml pipette within 5 seconds
- * Integral and replaceable 0.45um filter
- * Large LCD display
- * Eight speeds are available for aspirating and dispensing liquid



Technical Parameters:

Item No.	7062110200
Aspirate Speeds	25mL<5s (6 shift)
Dispense Speed	Motor (6 shift)/Gravity
Battery	Lithium-ion
Battery Working Time	8 hours of intermittence use
Charging Time	Approx 2 hours
Pipette	Glass or Plastic Pipette(0.1-100ml), Pasteur Pipettes
Filter	0.45 µm Hydrophobic

Ordering information:

Cat No.	Descriptions
7061110200	Levo Plus with AC adapter, spare 0.45um filter and wall stand, Euro plug
	Levo Plus with AC adapter, spare 0.45um filter and wall stand, North-America plug
	Levo Plus with AC adapter, spare 0.45um filter and wall stand, UK plug
Standard accessories	
17500062	Levo Plus charger
17500166	Levo Plus Lithium battery
17000762	Filter 0.45um, 1pc/pk

Electronic Pipette

Features:

- * A motor drive digital control pipette with multifunction Pipetting, Mixing, Stepper and Dilution.
- * 2 buttons handle all operation and setting.
- * Light weight, ergonomic design, small body dimension for easy handling that guarantees fatigue free pipetting.
- * High accuracy, high performance stepper motor assures precision and repeatability and eliminates manual pipetting errors.
- * A wide range of pipetting modules for selection.
- * Adjustable speeds for aspiration and dispensing.
- * Li-ion battery and two charging mode enable longer operation time.
- * Self calibration – By link it to a PC and a balance with USB connector, user can calibrate pipette by himself. No need to send it to the third party for calibration.



Technical Parameters:

Item No.	Volume Range	Increment	Test Volume	Inaccuracy		Imprecision	
			µL	µL	%	s.d.*µL	CV*%
7016201001	0.5-10µL	0.01µL	10	±0.10	±1.0	0.05	0.5
			1	±0.035	±3.5	0.03	3.0
7016201002	5-50µL	0.1µL	50	±0.40	±0.8	0.15	0.3
			5	±0.15	±3.0	0.125	2.5
7016201003	30-300µL	1µL	300	±1.8	±0.6	0.6	0.2
			30	±0.9	±3.0	0.21	0.7
7016201004	100-1000µL	5µL	1000	±6.0	±0.6	2.0	0.2
			100	±3.0	±3.0	0.6	0.6

*s.d. = Standard Deviation *CV = Coefficient of Variation

Pipette Stand

The round stand can be applied to the three major pipette series-TopPette, MicroPette and MicroPette Plus. It can stably and conveniently hang up to 6 single-channel and multi-channel pipettes at the same time.



The linear stand can be applied to the three major pipette series-TopPette, MicroPette and MicroPette Plus. It can stably and conveniently hang up to 6 single-channel and multi-channel pipettes at the same time.



The linear and round stands have been designed to fit perfectly of BIOBASE Pipette range, TopPette, MicroPette and MicroPette Plus Autoclavable Pipettes. The stands are convenient to hold up 6 pipettes both of single and multi-channel.

Ordering Information:

Cat. No	Descriptions
703000084	Round stand holds up to 6 pipettes, fit of TopPette, MicroPette and MicroPette Plus
703000085	Linear stand holds up to 6 pipettes, fit of TopPette, MicroPette and MicroPette Plus

Dispenser

DispensMate Bottle-Top Dispenser

Features:

- * Excellent chemical resistance
- * Fully autoclavable at 121°C
- * Easy to clean and maintain
- * Made of PTFE, FEP, BSG, PP
- * Four ranges of bottle-top dispenser cover a volume range from 0.5ml to 50ml
- * The optional flexible discharge tube with safety handle permits fast and precise dispensing
- * Vapor pressure Max. 500mbar, viscosity max. 500mm²/s, temperature max. 40°C, density max. 2.2g/cm³
- * DispensMate plus is supplied with S40, GL32, GL38, GL25, GL28 sized adapters



Technical Parameters:

Volume Range	Graduation	A \leq ±		CV \leq	
0.5-5ml	0.1ml	0.5%	25 μ l	0.1%	5 μ l
1.0-10ml	0.2ml	0.5%	50 μ l	0.1%	10 μ l
2.5-25ml	0.5ml	0.5%	125 μ l	0.1%	25 μ l
5.0-50ml	1.0ml	0.5%	250 μ l	0.1%	50 μ l

A = Accuracy; CV = Coefficient of variation.

Ordering Information:

Cat. No.	Volume Range	Cat. No.	Volume Range
Standard Accessories			
7032100101	0.5-5ml	17000069	S40, Adapter, 45/40mm
7032100102	1-10ml	17000817	GL32, Adapter, 45/32mm
7032100103	2.5-25ml	17400132	GL38, Adapter, 45/38mm
7032200104	5-50ml	17400133	GL25, Adapter, 32/25mm
		17400134	GL28, Adapter, 32/28mm
		17400021	Filling tube (m)
		17100073	Discharge tube (m)
Optional Accessories			
		17400037	Reagent Bottle (Brown, 1L)

Electronic Bottle-Top Dispenser



Features:

- * Motor operation minimizes the grip force.
- * Electronic control decreases the repetitive strain injury.
- * Remote control panel prevents manual disturbance during operation.
- * Two dispensing modes.
- * Dispenser.
- * Stepper function.

Technical Parameters:

Model	DFlow
Item No.	7012300001
Volume Range	0.01~99.99ml, Max piston lift is 10ml, resolution is 10 μ l
Volume Accuracy	R=0.2% CV=0.07%
Operating Temperature Range	10°C~30°C
Quality Control	DIN EN ISO 8655
Contro Type	External control, including the stirrer and the burette program

Automatic Micro Liquid Dispenser



Introduction:

The Automatic Micro Liquid Dispenser is equipped with a high-precision peristaltic pump and a robotic arm, which can quickly, accurately and consistently complete the automatic liquid dispensing operation, liberate the hands of the experimenter, and avoid mistakes while improving efficiency. The liquid dispensing accuracy of the product meets the minimum liquid dispensing volume as low as 5 μ l, and the filling time of 100 μ l in a 96-well plate is 10s.

Features:

- * Fast: 96-well plate 100 μ l adding time 10s
- * Accurate: 96-well plate 100 μ l liquid addition error \pm 1.5%
- * Efficient: 10 times the efficiency of manual operation
- * Intuitive: Graphical operation interface, one-key liquid addition

Technical Parameters:

Model	AMS-01
Dispensing Volume	5-9999 μ l(1 μ l increment)
Suitable Plate	8~96 well plate
Dispensing Way	Whole plate or any line, the liquid volume of the specified line can be set
Dispensing Speed	High-middle-low, can be adjustable
Dispensing Pipe	8-channel
Waste Liquid Handling	Movable water liquid slot
Auxiliary Function	Shake, rinse,suck, pipe wash
Display	7 inch touch display
Dispensing Precision	20 μ l \leq 5%; 100 μ l \leq 1.5%(96-well plate)
Dispensing Accuracy	20 μ l \pm 1.5%; 100 μ l \pm 1%(96-well plate)
Power Supply	220/110V, 50/60Hz
External Size	465*275*280mm
Net Weight	10kg
Packing Size	550*370*470mm
Gross Weight	27kg

Bath / Circulator Thermostatic Water Bath



Features:

- * PID temperature control, high temperature precision, with temperature deviation alarm.
- * The water tank is made of 304 stainless steel by one time stamping process, which is resistant to high temperature, corrosion and rust.
- * All-round heating, rapid heating, adjustable lid locking temperature.
- * Equipped with a water level sensor, when the water level is lower than the sensor, it will automatically stop heating.
- * The lid of the water bath can be adapted to various sizes of containers (inside diameter: $\phi 39\text{mm}$, $\phi 57\text{mm}$, $\phi 77\text{mm}$, 97mm).

Technical Parameters:

Model	BK-S2	BK-S4	BK-S6	BK-S8
Positions	2	4	6	8
Capacity	5L	10L	20L	26L
Temp. Range	RT~100°C			
Temp. Fluctuation	$\pm 0.5^\circ\text{C}$			
Timing Range	0~99h59min			
Display	OLED Display			
Function	Timing function, over-temperature alarm, anti-dry protection			
Consumption	600W	1000W	1500W	2000W
Power Supply	220V $\pm 10\%$, 50/60Hz(Standard); 110V, 60Hz(Optional)			
Internal Size(L*W*H) mm	300*150*150	325*300*145	505*300*150	620*315*135
External Size(L*W*H) mm	383*236*259	383*381*264	568*376*259	650*365*264
Package Size (L*W*H) mm	444*324*294	444*324*444	444*324*634	710*400*285
Net Weight	4.24kg	5.72kg	8.02kg	10kg
Gross Weight	4.7kg	6.2kg	8.5kg	13kg

Optional Tube Rack:

Model	BK-S2	BK-S4	BK-S6	BK-S8	
Max	$\phi 13\text{mm} \times 40$	1	3	5	7
Number	$\phi 16\text{mm} \times 40$	1	3	5	7



Features:

- * The shell adopts cold plate spraying, which improves the anti-corrosion ability of the whole machine.
- * The inner liner is made of high-quality 304 stainless steel, which is corrosion-resistant and not easy to rust.
- * Adjustable ring cover to meet the needs of different sizes of experimental instruments.
- * Real-time temperature value display, accurate temperature control, countdown display.
- * Hidden stretch drain, beautiful, convenient and durable.

Technical Parameters:

Model	BK-WB1	BK-WB2	BK-WB4	BK-WB6	BK-WB8
Capacity	3.5L	6.8L	13L	20L	26L
Temperature Range	RT+5~99.9°C				
Temperature Display Precision	0.1°C				
Temperature Fluctuation	$\pm 0.5^\circ\text{C}$				
Temperature Uniformity	$\pm 0.5^\circ\text{C}$				
Timing Range	1-999min				
Chamber Material	Integrated S.S.				
Heating Power	500W	600W	800W	1200W	1800W
Power Supply	Standard: 220V 50/60Hz; optional: 110V 50/60Hz				
Chamber Size(mm)	160*160*140	305*160*140	305*305*140	470*305*140	620*305*140
Outer Size(mm)	245*245*195	365*245*195	365*365*195	530*365*195	680*365*195
Net Weight	2.7kg	3kg	4.3kg	5.4kg	7kg
Packing Size(mm)	210*215*195	395*215*240	395*395*240	560*395*240	705*410*265
Gross Weight	3.5kg	3.7kg	5.3kg	6.7kg	8.6kg

Optional Tube Rack:

Model	BK-WB1	BK-WB2	BK-WB4	BK-WB6	BK-WB8	
Max Number	$\phi 13\text{mm} \times 40$	/	1	3	5	6
	$\phi 14\text{mm} \times 40$	/	1	3	5	5
	$\phi 16\text{mm} \times 40$	/	1	3	4	5
	$\phi 17\text{mm} \times 40$	/	1	2	4	5
	$\phi 19\text{mm} \times 40$	/	1	2	4	5
	$\phi 21\text{mm} \times 40$	/	1	2	3	5
	$\phi 23\text{mm} \times 40$	/	1	2	3	4
	$\phi 25\text{mm} \times 40$	/	/	/	2	2
	$\phi 27\text{mm} \times 40$	/	/	/	2	2
	$\phi 30\text{mm} \times 40$	/	/	/	1	1
	$\phi 17\text{mm} \times 12$	2	4	8	12	15
	$\phi 19\text{mm} \times 12$	1	3	5	10	12
	$\phi 21\text{mm} \times 12$	/	2	4	8	10
	$\phi 23\text{mm} \times 12$	/	2	4	8	10
	$\phi 27\text{mm} \times 12$	/	2	3	6	6
	$\phi 30\text{mm} \times 12$	/	1	3	5	6
	$\phi 32\text{mm} \times 12$	/	1	3	5	5

Thermostatic Water Tank



BK-W2

BK-W6

BK-W4

Features:

- * All-round heating, rapid temperature rise, adjustable lid locking temperature, constant temperature operation, making the experiment accurate.
- * OLED display, temperature, time and other parameters displayed in real time.
- * Intelligent algorithm monitoring, water shortage stops heating when turned on, and the working time of the instrument can be freely set.
- * The water tank is stamped and formed from stainless steel, which is resistant to high temperatures, corrosion, and rust; it is equipped with a load-bearing frame.

Technical Parameters:

Model	BK-W2	BK-W4	BK-W6
Type	1 row, 2 holes	2 rows, 4 holes	2 rows, 6 holes
Heating Power	600W	1000W	1500W
Chamber	Stainless steel		
Temp. Range	RT~100°C		
Temp. Fluctuation	±0.5°C		
Display	OLED		
Timing	Yes		
Capacity	5L	10L	20L
Power Supply	Standard: AC220V 50/60Hz, optional: AC110V 50/60Hz		
Chamber Size	300*150*150mm	325*300*145mm	505*300*150mm
External Size	385*280*275mm	385*420*275mm	570*420*275mm
Net Weight	6.15kg	7.85kg	11.3kg
Packing Size	444*294*324mm	444*444*324mm	634*444*324mm
Gross Weight	7.8kg	10.5kg	13.6kg

Optional Tube Rack:

Model		BK-W2	BK-W4	BK-W6
Max	φ13mm*40	1	3	5
Number	φ16mm*40	1	3	5



Constant Temperature Water Tank

Features:

- * Precise Timing
Timer can accurately control the heating time
Timing range: 0~9999 minutes/hours
Timing error: <1%
- * LCD Display
Real-time temperature display countdown display
- * Inside Design
Powder-coated steel outer shell, durable
The fully rounded inner cavity is easy to clean and disinfect
- * Temperature Difference Calibration
Equipped with temperature deviation calibration function
- * Temperature Control
PID microprocessor control
Standard over-temperature alarm function



WT-26

WT-100

Technical Parameters:

Model	WT-26	WT-100
Temp. Range	R.T.+5~100°C (Normal atmosphere)	
Temp. Fluctuation	±0.5°C	≤±2°C
Temp. Accuracy	0.1°C	
Capacity	30L	100L
Consumption	1500W	
Power Supply	220VAC±10%, 110VAC±10%; 50/60Hz	
Lid Size	φ37, φ58, φ79, φ100, φ120	
Internal Size(L*W*D)	500*300*200mm	1330*450*170mm
External Size(L*W*D)	665*364*281mm	1501*523*288mm
Package Size(L*W*D)	710*405*330mm	1550*575*330mm
Net Weight	15kg	40kg
Gross Weight	18kg	45kg

Features:

- * Microprocessor control, LED display.
- * Timing function and over-temperature protection.
- * External material: Cold rolled steel with anti bacteria powder coating.
- * Inner material: Stainless steel inner chamber.



WT-42

WT-60

Technical Parameters:

Model	WT-42	WT-60
Temp. Range	RT+5~100°C	
Temp. Fluctuation	≤±0.5°C	
Consumption	800W	1500W
Power Supply	AC110V/220V±10%, 50/60Hz	
Internal Size(L*W*H) mm	420*180*180	600*300*180
External Size(L*W*H) mm	580*250*270	760*370*270
Package Size(L*W*H) mm	640*310*310	820*440*310
Net Weight	10kg	15kg
Gross Weight	11kg	17kg

Thermostatic Shaking Water Bath



Applications:

It is a temperature-controlled water bath and oscillator combined experimental instrument, plant, biological, microbial, genetic, viral, environmental protection, medical and other scientific research, education and production departments for precision culture preparation indispensable laboratory equipment.

Features:

- * High quality digital display constant speed controller, constant speed without fluctuation.
- * The LCD display can simultaneously display the measured temperature, real-time speed and setting time.
- * With operating parameter memory function, call recovery function, temperature and speed alarm function.
- * Designed with a steady flow plate to prevent splashing in high-speed operation.
- * The inner chamber and fixture are made of high-quality stainless steel with good corrosion resistance.
- * The shell is made of high-quality steel plate, anticorrosive and durable.
- * Standard spring fixture, can be applied to any flask beaker, irregular sample, etc.

Technical Parameters:

Model	SHZ-A10
Temperature Control	PID microcomputer control
Temperature Range	RT~100°C
Display Precision	0.1°C
Rotation Range	20~300rpm
Shaking Amplitude	20mm
Timing Range	1~9999min/hour or continuous
Power Supply	Standard: 220V 50/60Hz, optional: 110V 50/60Hz
Fixture Plate Size	300*400mm
Chamber Size	490*390*170mm
Outer Size	720*480*530mm
Heating Power	1500W
Shaking Method	Reciprocating
Packing Size	792*612*616mm
Gross Weight	46kg



SWB-A/C



SWB-B

Features:

- * Microprocessor controller with LED display, high precision of controlling temperature.
- * Advanced multipurpose stainless steel spring clip.

Technical Parameters:

Model	SWB-A	SWB-B	SWB-C
Temp. Range	RT~100°C		RT~99.9°C
Oscillation Amplitude	30mm	24mm	20mm
Rotary Speed	60~300rpm	60~300rpm	60~300rpm
Shaking Mode	Rotation oscillation, continuous	Rotation oscillation & reciprocating, continuous	Reciprocating, continuous
Timing	0-120min		
Consumption	1500w	1550w	1500w
Power Supply	AC 110/220V±10%, 50/60Hz		
Internal Size(L*W*H) mm	490*390*170	490*390*150	490*390*170
External Size(L*W*H) mm	720*480*520		
Packing Size(L*W*H) mm	800*596*560	800*590*580	800*590*560
Gross Weight(kg)	48	52	48

Thermostatic Shaking Water Bath



Features:

- * Multi-stage speed, temperature and time control system. A variety of different speed, temperature, and time experiment modes can be set at one time, and the operation mode is automatically changed during operation.
- * Ultra-low speed start, after the speed is out of control, it will automatically lock and the start speed can be adjusted.
- * Silent fan design, forced convection mode and unique air duct design ensure good temperature uniformity.
- * The user can freely set three operation modes: forward rotation, reverse rotation, and alternating forward and reverse rotation.
- * LCD liquid crystal display, temperature, time and speed are displayed on the same interface.

Technical Parameters:

Model	SWB-301	SWB-302	SWB-303
Control	PID		
Display	LCD		
Shaking Mode	Rotatory shaking	Rotatory and Reciprocating shaking	Reciprocating shaking
Cyclotron Frequency Range	0; 20-300rpm/min (can do static culture, forward and reverse or alternate operation)		
Cyclotron Frequency Fensitivity	±1rpm		
Vibration Range	Φ26mm	Φ26mm or 26mm	26mm
Max. Capacity	100ml*24 or 250ml*15 or 500ml*11 or 1000ml*6		
Standard Accessory	Spring net box		
Optional Accessory	Flask clamp		
Shaking Plate Size	498*316mm		
Timing Range	0-9999h/min		
Temp. Range	RT~100°C		
Temp. Accuracy	±0.1°C		
Temp. Uniformity	≤0.1°C(37°C)		
Consumption	1400W		
Power Supply	AC110V/220V±10%,50/60HZ		
External Size(W*D*H)	640*620*550mm		
Package Size(W*D*H)	830*790*720mm		
Gross Weight	100kg		

Oil Bath



Application:

Widely used in scientific research, colleges and other enterprises and institutions laboratory distillation, drying, concentration, temperature stain chemical or biological products, can also be used for constant temperature testing experiments and auxiliary heating.

Features:

- * The inner liner is made of stainless steel plate and precision machining technology
- * High temperature and corrosion resistance
- * Short heat balance time and small temperature fluctuation
- * LED display of test data, intuitive and accurate

Technical Parameters:

Model	BJPX-OB2
Temperature Control Range	RT+5~300°C
Temperature Fluctuation	≤1°C
Power	600W
Capacity	3.54L
Heating Medium	High temperature thermal oil or distilled water
Power Supply	Standard: 220V 50/60Hz, optional: 110V 50/60Hz
External Size	235*265*190mm
Packing Size	330*330*300mm
Gross Weight	4kg

Oil Bath



Features:

- * LED display
- * Automatic protection for overheating
- * Material: Main body is issteel plate with baking varnish; Internal is imported stainless steel
- * Advanced recycle pump system ensures good evenness of temperature(OB-2)

Technical Parameters:

Model	OB-1	OB-2
Temperature Range	RT~300°C	
Temperature Fluctuation	≤1°C	
Temperature Control Precision	≤1°C	
Heating Power	2000W	
Power Supply	110V/220V±10%,50/60HZ	
Circulatory System	None	Have
Circuation Pump Flow Rate	None	6L/min
Workroom Cubage	280*280*300mm ³	300*300*280mm ³
Package Size(W*D*H)	520*420*400mm	710*460*570mm
Gross Weight	15kg	33kg

Super Constant Temperature Water Bath



Introduction:

Super Constant Temperature Water Bath, is made from imported corrosion-resistant plate with advanced manufacturing process, whose performance index accords with national standard requirements. It is of high precision to control temperature, strong anti corrosion, compact conformation, beautiful figure, saving energy sources, and long use life etc. It is applicable for precise constant temperature by direct or auxiliary heating in biology, physics, plants, chemicals, and environment protection etc.

Features:

- * Stainless steel inner chamber and upper cover.
- * High temperature resistance, corrosion resistance
- * External Material: cold rolled steel with powder coating.
- * PID Mircoprocessor controller, LED display.
- * The thermal equilibrium time is short, the temperature fluctuation is small, and the uniformity is good.

Technical Parameters:

Model	WB-501	WB-601
Capacity	20L	
Temp.range	RT+5-100°C	
Temp. Fluctuation	≤±0.1°C	
Display	LED	
Consumption	800W	1000W
Flow Rate of Pump	≥6L/min	
Power Supply	AC110/220V±10%, 50/60Hz	
Workroom Size(L*D*H)mm	280*240*180	
Internal Size(L*D*H)mm	400*280*180	
External Size(L*D*H)mm	470*360*390	
Packing Size(L*D*H)mm	520*410*420	
Net Weight(kg)	12	
Gross Weight(kg)	14	

Pump

Vacuum Pump



Features:

- * Oil free, clean exhausted air by built-in filter.
- * Automatic cooling exhaust system ensures 24h operation continuously.
- * The pressure adjustable design can satisfy a certain range of vacuum and gas velocity.
(This function does not apply to model GM-0.20)
- * TEFLON surface treatment, anti-gas corrosion.
- * Anticorrosive vacuum pump: GM-0.33IIP, GM-0.5P, GM-0.5IIP, GM-1.0P.

Technical Parameters:

Model	GM-0.20	GM-0.5II	GM-0.5	GM-0.33II	GM-1.0
Pump Head	1	2	1	1	2
Speed of Evacuation	15L/Min	30L/Min	30L/Min	20L/Min	60L/Min
Ultimate Pressure	0.075Mpa	0.095Mpa	0.08Mpa	0.08Mpa	0.08Mpa
Vacuum	250mbar	50mbar	200mbar	200mbar	200mbar
Pressure	30 Psi Positive or negative pressure	Negative pressure	30 Positive, Positive or negative pressure	Negative pressure	30 Positive, Positive or negative pressure
Inlet	φ6mm	φ6mm	φ6mm	φ6mm	φ6mm
Outlet	φ6mm	Silencer	φ6mm	Silencer	φ6mm
Working Temp.	7-40°C				
Body Temp.	<55°C				
Noise	<60dB				
Motor Power Consumption	75W	160W			
Power Supply	AC110/220V±10%, 50/60Hz				
Diaphragm	NBR				
Valves	/	NBR			
Net Weight(kg)	4	10	6.6	6.2	10
Gross Weight(kg)	4.5	11	7.6	7.5	11
External Size(L*W*H) mm	195*98*156	300*120*235	210*160*235	215*120*235	300*160*235
Package Size(L*W*H) mm	330*210*240	314*205*316	300*210*310	315*200*310	380*340*270

Standard Peristaltic Pump



Introduction:

Peristaltic pumps are mainly used for various liquid transfer. The peristaltic pump driver provides power to drive the pump head to run, and the rotor in the pump head rotates, relying on the pumping efficiency generated by the alternate extrusion and release of several rotors along an elastic hose to work. The squeezed fluid in the tube produces flow output, and when the tube returns to its original state by its own elasticity after the pressure disappears, the volume increases, a vacuum is generated, the fluid is sucked in, and the cycle is repeated.

Features:

- * Full speed function: realize fast filling and emptying.
- * Speed regulation function: The speed can be adjusted manually, or controlled through an external control interface.
- * Direction function: reversible forward and reverse.
- * Display function: display the current speed, direction and status.
- * Power-off memory function: memorize the working state before power-off (continuous work for more than 5s)

Technical Parameters:

Model	SPP-100-2J	SPP-300-2J
Speed Range	0.1-100rpm	0.1-300rpm
Speed Resolution	0.1rpm	0.1-99.9rpm:0.1rpm; 100-300rpm:1rpm
Adjusting Method	Membrane button continuous adjustment	
Display	LED displays current speed	
Power	≤30w	≤75w
Flow Range	0.0002-380ml/min	0.06~1140ml/min
External Size	254*140*140mm	
Protection Class	IP31	
Pump Model	YZ15A	
Suitable Pump Hose	13# 14# 19# 16# 25# 17# 18#	
Ambient Temperature	10°C-40°C	
Relative Humidity	≤80%	
Atmosphere Pressure	860hPa-1060hPa	
Power Supply	100-240V 50/60HZ	100-270V 50/60HZ
Full Speed Function	Fast filling and emptying	
Speed Adjustable Function	Manual speed adjustment	
Direction Function	Reversible	
Display Function	Display current speed, direction and status	
Power-off memory function	Memory of working status before power failure (working continuously for more than 5 seconds)	
Standard Accessories	YZ15A pump head, 2 meters of 14# pump hose	
Optional Accessory	Foot switch	
Packing Size	390mm*340mm*240mm	
Gross Weight	3.3Kg	

Dispensing Peristaltic Pump



DPP-100-BF/ DPP-300-BF



DPP-600-BF

Features:

- * Direction control, reverse direction.
- * With fast cleaning, emptying function, back suction function, prevent liquid dripping.
- * LCD display.
- * The function of communicating with the upper computer or computer.
- * Distribution function includes distribution liquid quantity, distribution times, time interval and other functions.
- * Automatic storage of various user parameters.
- * Can be calibrated for flow and distribution fluid volume to improve accuracy.
- * Forced air cooling heat dissipation, to ensure the normal use of products.

Technical Parameters:

Model	DPP-100-BF	DPP-300-BF	DPP-600-BF
Speed Range	0.1-100rpm	0.1-300rpm	0.1-600rpm
Speed Resolution	0.1rpm	0.1rpm	0.1rpm
Flow Range	0.16μL/min~500mL/min	1.6μL/min~1.5L/min	0.052-3000ml/min
Dispensed Fluid Volume	0.01mL~9.99L	0.01mL~99.99L	
Dispensed Number	0~9999		
Dispensing Interval Time	0.1s~99.9min		
Suction Back Time	0~99.9s		
External Control Input	4~20Ma, 0~5V, 0~10V, 0~10KHz Flow control, forward and reverse, start and stop control		
External Control Output	Start/stop, direction signal, speed signal		
Power Supply	90~264V 50Hz/60Hz		
Power	<40W	<60W	<140W
Working Condition	Ambient temperature: 0~40°C; Relative Humidity: <80%		
Protection Class	IP31		
Adjustable Pump Head	YZ15A, YZ25, YZ II 15, YZ II 25, DG-1, DG-2, DG-4		
Operation Method	Mechanical buttons and knob coding switches complete all operations		
Direction Control	Reversible in both directions		
Full Speed Function	Quick cleaning and emptying function		
Back Suction Function	Prevent liquid from dripping		
Display	128*64 dot matrix Chinese character LCD displays all information		
Communication Function	It has the function of communicating with the host computer or computer		
Flow Function	It can deliver liquid according to the set flow rate		
Distribution Function	Including the functions of dispensing liquid volume, dispensing times, time interval, etc.		
Standard Accessories	YZ15A pump head, 2 meters of 14# pump tube		
Optional Accessories	Foot switch, 4~20mA, 0~5V, 0~10V, 0~10KHz external control		
External Size	300*171*189mm		330*250*190mm
Net Weight	3.2kg		5.0kg
Packing Size	390*340*240mm		390*340*240mm
Gross Weight	4.1Kg		5.7Kg

Standard Peristaltic Pump SPP Series



Features:

- * LED display.
- * Support RS485 / MODBUS communication protocol, analog control (0-5V, 0-10V, 4-20mA...) foot switch control.
- * Program control.
- * Memory function——data will be stored in time after power off.
- * Full speed function——one button to control full speed operation, used for quick cleaning, filling and emptying tubes, etc.

Technical Parameters:

Model	SPP-BT100M	SPP-BT300M	SPP-BT600M
Pump Head	YZ1515x, YZ2515x, DG series(only SPP-BT100M)		
Speed Range	0.1-100rpm(Reversible)	0.1-300rpm(Reversible)	0.1-600rpm(Reversible)
Speed Resolution	0.1rpm		
Flow Range	0.0015-380ml/min	0.007-1140ml/min	0.007-2280ml/min
Filling Precision	<±0.5%		
Display	4-LED display		
Back Suction Speed	10~100rpm	10~300rpm	
Optional Accessory	Foot switch		
Environmental Conditions	Temperature: 0 ~ 40 °C; Humidity: < 80%, no condensation		
Consumption	22W	35W	50W
Power Supply	AC110/220V±10%, 50/60Hz		
Instrument Size(W*D*H)	234*154*143mm		254*184*150mm
Package Size(W*D*H)	393*243*243mm		403*283*253mm
Gross Weight	5.15kg		5.8kg

Pump Head:



Pump Parameters:

Standard Peristaltic Pump SPP Series		Model	SPP-BT100M	SPP-BT300M	SPP-BT600M
		Speed Range	0.1-100rpm (Reversible)	0.1-300rpm (Reversible)	0.1-600rpm (Reversible)
		Tubing	(Reversible)	(Reversible)	(Reversible)
Pump	YZ1515x	13#,14#,19#, 16#,25#,17#,18#	0.007-380ml/min	0.007-1140ml/min	0.007-2280ml/min
	YZ2515x	15#,24#	0.17-290ml/min	0.17-870ml/min	0.17-1740ml/min
Head& Single channel flow	2*YZ1515x	13#,14#,19#, 16#,25#,17#,18#	0.007-380ml/min	0.007-1140ml/min	0.007-2280ml/min
	2*YZ2515x	15#,24#	0.17-290ml/min	0.17-870ml/min	0.17-1740ml/min
flow	DG-1(6)	0.5*0.8, 1*1, 2*1, 2.4*0.8, 3*1	0.002~36ml/min	/	/
	DG-1(10)		0.0015~27ml/min	/	/
	DG-2(6)		0.002~36ml/min	/	/
	DG-2(10)		0.0015~27ml/min	/	/
	DG-4(6)		0.002~36ml/min	/	/
	DG-4(10)		0.0015~27ml/min	/	/

Remark: Customers can choose any one model hose as the standard configuration and the standard length is 2 meters.

Intelligent Flow Rate Peristaltic Pump FPP Series



Features:

- * Storage function—user data storage function:(9 sets of filling data) , support RS485/MODBUS communication protocol, analog control ((0-5V, 0-10V, 4-20mA...)).
- * External control function—Multiple mode selection: communication mode, analog mode, foot switch control.Provide customized services.
- * Memory function—data will be stored in time after power off.
- * Calibration function—intelligent flow calibration: after setting the target flow, input the actual flow value, and the system will automatically carry out flow calibration to ensure the flow accuracy.
- * Full speed function—one button to control full speed operation, used for quick cleaning, filling and emptying tubes, etc
- * Suckback function—By setting Suckback angle and Suckback speed to prevent liquid dripping and ensure fluid accuracy.
- * Lock screen function—lock screen design, error proof touch, application more secure.
- * LCD touch screen, real-time display of operation status and working parameters.
- * Whole housing design-stainless steel housing, sturdy and durable , multi-face seamless whole housing design, Long service life, high cost performance.

Technical Parameters:

Model	FPP-BT100LC	FPP-BT300LC	FPP-BT600LC
Pump Head	YZ1515x, YZ2515x, DG series(only FPP-BT100LC)		
Speed Range	0.1-100rpm(Reversible)	0.1-300rpm(Reversible)	0.1-600rpm(Reversible)
Speed Resolution	0.1rpm		
Flow Range	0.0015-380ml/min	0.007-1140ml/min	0.007-2280ml/min
Filling Precision	<±0.5%		
Display	LCD		
Back Suction Angle	10°~720°		
Back Suction Speed	10~100rpm	10~300rpm	
Optional Accessory	Foot switch		
Environmental Conditions	Temperature: 0 ~ 40 °C; Humidity: < 80%, no condensation		
Consumption	22W	35W	50W
Power Supply	AC110/220V±10%, 50/60Hz		
Instrument Size(W*D*H)	212*140*240mm		
Package Size(W*D*H)	363*253*353mm		
Gross Weight	6kg		6.9kg

Pump Head:



Pump Parameters:

Standard Peristaltic Pump SPP Series		Model	FPP-BT100LC	FPP-BT300LC	FPP-BT600LC
		Speed Range	0.1-100rpm (Reversible)	0.1-300rpm (Reversible)	0.1-600rpm (Reversible)
		Tubing			
Pump Head& Single channel flow	YZ1515x	13#,14#,19#, 16#,25#,17#,18#	0.007-380ml/min	0.007-1140ml/min	0.007-2280ml/min
	YZ2515x	15#,24#	0.17-290ml/min	0.17-870ml/min	0.17-1740ml/min
	2*YZ1515x	13#,14#,19#, 16#,25#,17#,18#	0.007-380ml/min	0.007-1140ml/min	0.007-2280ml/min
	2*YZ2515x	15#,24#	0.17-290ml/min	0.17-870ml/min	0.17-1740ml/min
	DG-1(6)		0.002~36ml/min	/	/
	DG-1(10)		0.0015~27ml/min	/	/
	DG-2(6)	0.5*0.8, 1*1, 2*1,	0.002~36ml/min	/	/
	DG-2(10)	2.4*0.8, 3*1	0.0015~27ml/min	/	/
	DG-4(6)		0.002~36ml/min	/	/
	DG-4(10)		0.0015~27ml/min	/	/

Remark: Customers can choose any one model hose as the standard configuration and the standard length is 2 meters.

Dispensing Peristaltic Pump DPP Series



Features:

- * Storage function—user data storage function:(9 sets of filling data) , support RS485/MODBUS communication protocol, analog control ((0-5V, 0-10V, 4-20mA...)).
- * External control function—Multiple mode selection: communication mode, analog mode, foot switch control.Provide customized services.
- * Memory function—data will be stored in time after power off.
- * Calibration function—intelligent flow calibration: after setting the target flow, input the actual flow value, and the system will automatically carry out flow calibration to sure the flow accuracy.
- * Full speed function—one button to control full speed operation, used for quick cleaning, filling and emptying tubes, etc
- * Suckback function—By setting Suckback angle and Suckback speed to prevent liquid dripping and ensure fluid accuracy.
- * Lock screen function—lock screen design, error proof touch, application more secure.
- * LCD touch screen, real-time display of operation status and working parameters.
- * Whole housing design-stainless steel housing, sturdy and durable , multi-face seamless whole housing design, Long service life, high cost performance.

Technical Parameters:

Model	DPP-BT100FC	DPP-BT300FC	DPP-BT600FC
Pump Head	YZ1515x, YZ2515x, DG series(only DPP-BT100FC)		
Speed Range	0.1-100rpm(Reversible)	0.1-300rpm(Reversible)	0.1-600rpm(Reversible)
Speed Resolution	0.1rpm		
Flow Range	0.0015-380ml/min	0.007-1140ml/min	0.007-2280ml/min
Filling Precision	<±0.5%		
Display	LCD		
Back Suction Angle	10°~720°		
Back Suction Speed	10~100rpm	10~300rpm	
Optional Accessory	Foot switch		
Environmental Conditions	Temperature: 0 ~ 40 °C; Humidity: < 80%, no condensation		
Consumption	22W	35W	50W
Power Supply	AC110/220V±10%, 50/60Hz		
Instrument Size(W*D*H)	212*140*240mm		
Package Size(W*D*H)	363*253*353mm		
Gross Weight	6kg	6.9kg	

Pump Head:



YZ1515X

DG Series

YZ2515X

Pump Parameters:

Standard Peristaltic Pump SPP Series	Model	DPP-BT100FC	DPP-BT300FC	DPP-BT600FC	
	Speed Range		0.1-100rpm	0.1-300rpm	0.1-600rpm
Tubing		(Reversible)	(Reversible)	(Reversible)	
Pump Head& Single channel flow	YZ1515x	13#,14#,19#, 16#,25#,17#,18#	0.007-380ml/min	0.007-1140ml/min	0.007-2280ml/min
	YZ2515x	15#,24#	0.17-290ml/min	0.17-870ml/min	0.17-1740ml/min
	2*YZ1515x	13#,14#,19#, 16#,25#,17#,18#	0.007-380ml/min	0.007-1140ml/min	0.007-2280ml/min
	2*YZ2515x	15#,24#	0.17-290ml/min	0.17-870ml/min	0.17-1740ml/min
	DG-1(6)	0.5*0.8, 1*1, 2*1, 2.4*0.8, 3*1	0.002~36ml/min	/	/
	DG-1(10)		0.0015~27ml/min	/	/
	DG-2(6)		0.002~36ml/min	/	/
	DG-2(10)		0.0015~27ml/min	/	/
	DG-4(6)		0.002~36ml/min	/	/
	DG-4(10)		0.0015~27ml/min	/	/

Remark: Customers can choose any one model hose as the standard configuration and the standard length is 2 meters.

Dispensing Peristaltic Pump BT-F Series

Features:

- * True color LCD display, touch screen and button operation;
- * LF-touch-OS software system, efficient and stable, with good human-computer interaction mode, convenient product customization and upgrade;
- * With liquid allocation, time allocation, copy allocation of three working modes;
- * Pre-store five groups of assignment parameters for various working modes;
- * Motor precise rotation Angle control technology reduces the traditional time control distribution mode due to motor slow start and other factors
- * The distribution error caused by;
- * With start-stop, positive and negative rotation, full speed, speed regulation, state memory and other basic functions;
- * Speed resolution of 0.1rpm;
- * Flow display, flow control, fluid accumulation;
- * With flow correction function;
- * Peristaltic pump expert system for maximum user convenience;
- * Intelligent temperature control function to minimize the noise of peristaltic pump;
- * External high& low-level control start and stop, positive and negative, simple packing, optical coupling isolation; External control analog quantity to adjust the speed;
- * RS485 communication, compatible with Modbus protocol, convenient to connect with various control devices;
- * The internal structure adopts double-layer isolation design, and the circuit board is sprayed with three-proof paint process to achieve dustproof and moisture-proof effect;
- * Strong anti-interference characteristics, wide voltage design, suitable for complex power supply environment;
- * The driver shell is made of ABS engineering plastic, streamline design, beautiful and practical;
- * Multiple pump heads can be installed for different combination of pump heads and drivers;
- * The function of distributing filling can be realized through the external pedal switch to control the start and stop



Technical Parameters

Model	BT101F	BT301F	BT601F
Flow Range	0.0001~720ml/min	0.006~1690ml/min	0.006~2900ml/min
Rotation Range	0.1~150rpm	0.1~350rpm	0.1~600rpm
Speed Resolution	0.1rpm		
Dispensed Liquid Volume Range	0.05ml~9999l		
Dispensed Frequency Range	1 to 999 times, "0" means infinite loop		
Dispensed Interval Time	0.1~999.9 seconds/minute/hour, time unit is adjustable		
Speed Accuracy	<±0.2%		
Power Supply	AC100~240V, 50Hz/60Hz		
Power	<30W	<40W	<50W
External Control Interface	External control input level 5V, 12V (standard), 24V (optional);		
Communication Interface	external control analog 0-5V (standard), 0-10V, 4-20mA (optional) RS485 communication, compatible with Modbus protocol		
Working Environment	Ambient temperature 0~40°C, relative humidity <80%		
Protection Level	IP31		
Overall Dimensions (L*W*H)	261*180*197mm		
Drive Weight	4.5kg	4.7kg	4.9kg
Packing Size	430*290*320mm		
Gross Weight	8kg		

Pump Head:



DG type



DT type



YZ15/YZ25



YT15/YT25

Applicable Pump Head, Hose& Flow Parameters

Driver Model	Applicable pump head	Number of channels	Applicable hose	Single channel flow rate (ml/min)
BT101F	DG (6 Scroll wheel)	1、2、4	Wall thickness 0.8~1mm, Inner diameters≤3.17mm	0.0002~49
	DG (10 Scroll wheel)	1、2、4	Wall thickness 0.8~1mm, Inner diameters≤3.17mm	0.0001~41
	DT10-18	1	13#14#, Wall thickness 0.8~1mm, Inner diameters≤3.17mm	0.0002~82
	DT10-28	2	13#14#, Wall thickness 0.8~1mm, Inner diameters≤3.17mm	0.0002~82
	YZ15	1	13#14#19#16#25#17#	0.006~420
	YZ25	1	15#24#	0.16~420
	YT15	1	13#14#19#16#25#17#18#	0.006~570
BT301F	YT25	1	15#24#35#36#	0.17~720
	YZ15	1	13#14#19#16#25#17#	0.006~990
	YZ25	1	15#24#	0.16~990
	YT15	1	13#14#19#16#25#17#18#	0.006~1300
BT601F	YT25	1	15#24#35#36#	0.16~1690
	YZ15	1	13#14#19#16#25#17#	0.006~1700
	YZ25	1	15#24#	0.16~1700
	YT15	1	13#14#19#16#25#17#18#	0.006~2300
BT601F	YT25	1	15#24#35#36#	0.16~2900

Remark: Customers can choose any one model hose as the standard configuration and the standard length is 2 meters.

Flow Rate Peristaltic Pump BT-L Series

Features:

- * True color LCD screen display, touch screen plus button operation;
- * LF-Touch-OS software system;
- * It has basic functions such as start and stop, forward and reverse, full speed, speed regulation, state memory, etc.;
- * Rotational speed resolution is 0.1 rpm;
- * Flow display, flow control, liquid volume accumulation;
- * With flow correction function;
- * Unique "simple sub-assembly" function to realize repeated timing and quantitative transmission, eliminating the need for time controllers;
- * Peristaltic pump expert system, which is convenient for users to the greatest extent;
- * Intelligent temperature control function, minimize the noise of the peristaltic pump, 45 decibels ultra-quiet design;
- * External control high and low-level control start and stop, positive and negative, simple subassembly, optocoupler isolation; external control analog quantity adjusts the speed;
- * RS485 communication, compatible with Modbus protocol, convenient to connect with various control equipment;
- * The internal structure adopts a double-layer isolation design, and the circuit board is sprayed with three anti-paint technology to achieve the effect of dust and moisture;
- * Super anti-interference characteristics, wide voltage design, suitable for complex power supply environment;
- * The drive housing material is made of ABS engineering plastics, streamlined design, simple and beautiful;
- * A variety of pump heads can be installed to achieve different combinations of pump heads and drivers.



Technical Parameters

Model	BT101L	BT301L	BT601L
Flow Range	0.0001~720ml/min	0.006~1690ml/min	0.006~2900ml/min
Rotation Range	0.1~150rpm	0.1~350rpm	0.1~600rpm
Speed Resolution	0.1rpm		
Speed Accuracy	<±0.2%		
Power Supply	AC100~240V, 50Hz/60Hz		
Power	<30W	<40W	<50W
External Control Interface	External control input level 5V, 12V (standard), 24V (optional); external control analog 0-5V (standard), 0-10V, 4-20mA (optional)		
Communication Interface	RS485 communication, compatible with Modbus protocol		
Working Environment	Ambient temperature 0~40°C, relative humidity <80%		
Protection Level	IP31		
Overall Dimensions (L*W*H)	261*180*197mm		
Drive Weight	4.5kg	4.7kg	4.9kg
Packing Size	430*290*320mm		
Gross Weight	8kg		

Pump Head:



DG type



DT type



YZ15/YZ25



YT15/YT25

Applicable Pump Head, Hose & Flow Parameters

Driver Model	Applicable pump head	Number of channels	Applicable hose	Single channel flow rate (ml/min)
BT101L	DG (6 Scroll wheel)	1, 2, 4	Wall thickness 0.8~1mm, Inner diameters≤3.17mm	0.0002~49
	DG (10 Scroll wheel)	1, 2, 4	Wall thickness 0.8~1mm, Inner diameters≤3.17mm	0.0001~41
	DT10-18	1	13#14#, Wall thickness 0.8~1mm, Inner diameters≤3.17mm	0.0002~82
	DT10-28	2	13#14#, Wall thickness 0.8~1mm, Inner diameters≤3.17mm	0.0002~82
	YZ15	1	13#14#19#16#25#17#	0.006~420
	YZ25	1	15#24#	0.16~420
	YT15	1	13#14#19#16#25#17#18#	0.006~570
BT301L	YT25	1	15#24#35#36#	0.17~720
	YZ15	1	13#14#19#16#25#17#	0.006~990
	YZ25	1	15#24#	0.16~990
	YT15	1	13#14#19#16#25#17#18#	0.006~1300
BT601L	YT25	1	15#24#35#36#	0.16~1690
	YZ15	1	13#14#19#16#25#17#	0.006~1700
	YZ25	1	15#24#	0.16~1700
	YT15	1	13#14#19#16#25#17#18#	0.006~2300
BT601L	YT25	1	15#24#35#36#	0.16~2900

Remark: Customers can choose any one model hose as the standard configuration and the standard length is 2 meters.

Standard Peristaltic Pump BT-S Series

Features:

- * 4-digit LED digital tube displays the speed and working mode;
- * LF-LED-OS software system;
- * LED indicator shows the working status of positive and negative, internal control, external control, foot switch, etc.;
- * Toggle switch and knob are combined for operation;
- * It has basic functions such as start and stop, forward and reverse, full speed, speed regulation, state memory, etc.;
- * Simple dispensing control, realizing the function of repeatedly transferring quantitative liquids;
- * Streamlined plastic shell design, simple and stylish;
- * Large torque output, different pump heads can be installed to realize multi-channel and driver combination;
- * The internal structure adopts a double-layer isolation design, and the circuit board is sprayed with three anti-paint technology to achieve the effect of dust and moisture;
- * Super anti-interference characteristics, wide voltage design, suitable for complex power supply environment;
- * External control high and low-level control start and stop, positive and negative, simple subassembly, optocoupler isolation; external control analog quantity adjusts the speed;
- * RS485 communication, support Modbus protocol, convenient to connect with various control equipment;
- * It can be equipped with foot switch, pulse dampener, leak detector and other optional accessories.



Technical Parameters

Model	BT101S	BT301S	BT601S
IFlow Range	0.0001~720ml/min	0.006~1690ml/min	0.006~2900ml/min
Rotation Range	0.1~150rpm	0.1~350rpm	0.1~600rpm
Speed Resolution	0.1~100rpm: 0.1rpm; 100~600rpm: 1rpm		
Speed Accuracy	<±0.5%		
Power Supply	AC100~240V, 50Hz/60Hz		
Power	<30W	<40W	<50W
External Control Interface	External control input level 5V, 12V (standard), 24V (optional); external control analog 0-5V (standard), 0-10V, 4-20mA (optional)		
Communication Interface	RS485 communication, compatible with Modbus protocol		
Working Environment	Ambient temperature 0~40°C, relative humidity <80%		
Protection Level	IP31		
Overall Dimensions (L*W*H)	261*180*197mm		
Drive Weight	4.5kg	4.7kg	4.9kg
Packing Size	430*290*320mm		
Gross Weight	8kg		

Pump Head:



DG type



DT type



YZ15/YZ25



YT15/YT25

Applicable Pump Head, Hose & Flow Parameters

Driver Model	Applicable pump head	Number of channels	Applicable hose	Single channel flow rate (ml/min)
BT101S	DG (6 Scroll wheel)	1, 2, 4	Wall thickness 0.8~1mm, Inner diameters≤3.17mm	0.0002~49
	DG (10 Scroll wheel)	1, 2, 4	Wall thickness 0.8~1mm, Inner diameters≤3.17mm	0.0001~41
	DT10-18	1	13#14#, Wall thickness 0.8~1mm, Inner diameters≤3.17mm	0.0002~82
	DT10-28	2	13#14#, Wall thickness 0.8~1mm, Inner diameters≤3.17mm	0.0002~82
	YZ15	1	13#14#19#16#25#17#	0.006~420
	YZ25	1	15#24#	0.16~420
	YT15	1	13#14#19#16#25#17#18#	0.006~570
BT301S	YT25	1	15#24#35#36#	0.17~720
	YZ15	1	13#14#19#16#25#17#	0.006~990
	YZ25	1	15#24#	0.16~990
	YT15	1	13#14#19#16#25#17#18#	0.006~1300
BT601S	YT25	1	15#24#35#36#	0.16~1690
	YZ15	1	13#14#19#16#25#17#	0.006~1700
	YZ25	1	15#24#	0.16~1700
	YT15	1	13#14#19#16#25#17#18#	0.006~2300
	YT25	1	15#24#35#36#	0.16~2900

Remark: Customers can choose any one model hose as the standard configuration and the standard length is 2 meters.

Safety Storage Cabinet

Features:

- * Two-layer anti-fire steel plate with 38mm between two steel plates for insulation.
- * Main body material: 1.0mm steel plate painted with epoxy resin.
- * Safety: Three-linkage lock. The door has two keys and is available to use padlock which realize safe management of double-locked with two key holders.
- * 50mm height anti-leakage liquid tank ensures no liquid overflow.
- * Specific warning labels for different kinds of safety storage cabinet.
- * Installed with double air vents which are set with anti-fire devices.
- * Adjustable anti-leakage shelves.
- * An electrostatic grounded conductive port for easy connection to an electrostatic ground wire.

Flammable Chemicals Storage Cabinet



Technical Parameters:

Model	BKSC-4Y	BKSC-12Y	BKSC-22Y	BKSC-30Y	BKSC-45Y	BKSC-60Y	BKSC-90Y
Capacity	4 gallon(15L)	12 gallon(45L)	22 gallon(83L)	30 gallon(114L)	45 gallon(170L)	60 gallon(227L)	90 gallon(340L)
Material	Double-layer anti-fire cold-rolled steel						
Adjustable Shelf	1 pc		3 pcs	1 pc	2 pcs		
Door	Single/Manual			Double/Manual			
External Size (W*D*H) mm	430*430*560	590*460*890	600*460*1650	1090*460*1120	1090*460*1650	860*860*1650	1090*860*1650
Package Size (W*D*H) mm	505*505*585	665*535*915	680*540*1790	1170*540*1260	1170*540*1790	940*940*1790	1170*940*1790
Gross Weight	28kg	50kg	93kg	101kg	138kg	170kg	200kg

series yellow safety cabinet for storing all kinds of flammable materials, with flashing point below 45°C.

Combustible Chemicals Storage Cabinet



Technical Parameters:

Model	BKSC-4R	BKSC-12R	BKSC-22R	BKSC-30R	BKSC-45R	BKSC-60R	BKSC-90R
Capacity	4 gallon(15L)	12 gallon(45L)	22 gallon(83L)	30 gallon(114L)	45 gallon(170L)	60 gallon(227L)	90 gallon(340L)
Material	Double-layer anti-fire cold-rolled steel						
Adjustable Shelf	1 pc		3 pcs	1 pc	2 pcs		
Door	Single/Manual			Double/Manual			
External Size (W*D*H) mm	430*430*560	590*460*890	600*460*1650	1090*460*1120	1090*460*1650	860*860*1650	1090*860*1650
Package Size (W*D*H) mm	505*505*585	665*535*915	680*540*1790	1170*540*1260	1170*540*1790	940*940*1790	1170*940*1790
Gross Weight	28kg	50kg	93kg	101kg	138kg	170kg	200kg

series red safety cabinet for storing various kinds of flammable materials with flashing points above 45°C.

Weak Acid and Alkali Chemicals Storage Cabinet



Technical Parameters:

Model	BKSC-4B	BKSC-12B	BKSC-22B	BKSC-30B	BKSC-45B	BKSC-60B	BKSC-90B
Capacity	4 gallon(15L)	12 gallon(45L)	22 gallon(83L)	30 gallon(114L)	45 gallon(170L)	60 gallon(227L)	90 gallon(340L)
Material	Double-layer anti-fire cold-rolled steel, PP tray						
Adjustable Shelf	1 pc		3 pcs	1 pc	2 pcs		
Door	Single/Manual			Double/Manual			
External Size (W*D*H) mm	430*430*560	590*460*890	600*460*1650	1090*460*1120	1090*460*1650	860*860*1650	1090*860*1650
Package Size (W*D*H) mm	505*505*585	665*535*915	680*540*1790	1170*540*1260	1170*540*1790	940*940*1790	1170*940*1790
Gross Weight	28kg	50kg	93kg	101kg	138kg	170kg	200kg

series blue safety cabinet for storing weak acid, weak alkali and weak corrosive items.

Strong Acid & Alkali Storage Cabinet

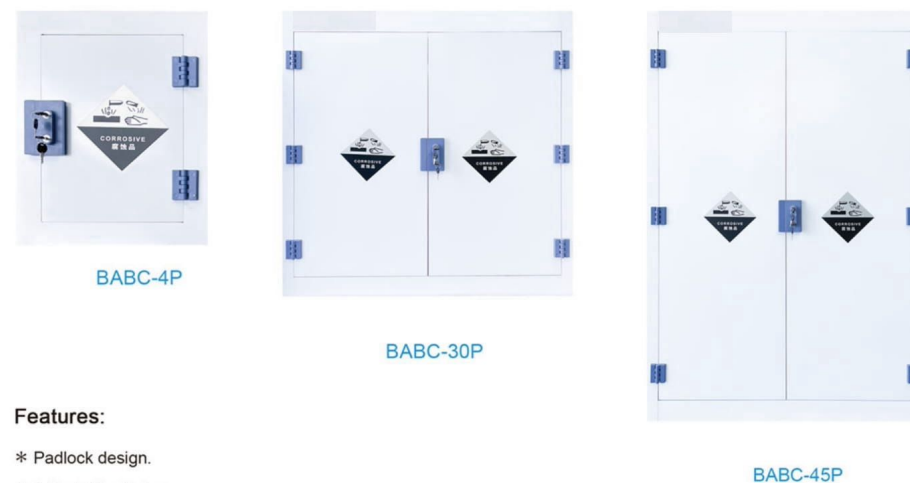

Features:

- * Padlock design.
- * Adjustable shelves.
- * Anti-corrosive materials for strong acid and alkali.
- * Customizable.

Technical Parameters:

Model	BABC-4P	BABC-12P	BABC-20P	BABC-28P	BABC-30P	BABC-45P	BABC-60P	BABC-90P
Capacity	4 gallon(15L)	12 gallon(45L)	20 gallon(75L)	28 gallon(105L)	30 gallon(114L)	45 gallon(170L)	60 gallon(227L)	90 gallon(340L)
Material	pp							
Adjustable shelf	Optional	1 pc		2 pcs				
Door	Single/Manual		Double/Manual					
External Size (W*D*H) mm	430*430*560	590*460*890	910*590*890	910*600*900	1090*460*1120	1090*460*1650	860*860*1650	1090*860*1650
Package Size (W*D*H) mm	515*515*695	675*545*1025	995*675*1025	995*685*1035	1175*545*1255	1175*545*1785	945*945*1785	1173*943*1785
Gross Weight	16kg	30kg	46kg	48kg	58kg	72kg	90kg	107kg

Pathology Lab Equipment

Flow Chart

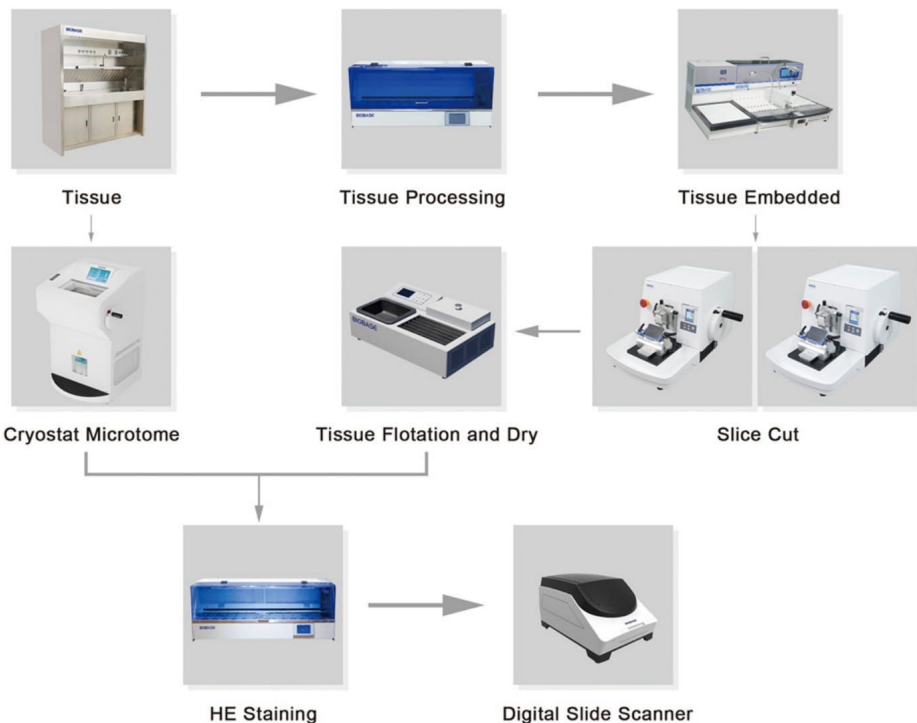

Content

257 Consumables	268 Tissue Flotation Water Bath & Slide Dryer
259 Automated Tissue Processor	271 Tissue Flotation Water Bath
261 Manual Rotary Microtome	272 Slide Dryer (Hot Plate)
263 Semi-Automatic Microtome	273 Automated Tissue Stainer
264 Automatic Microtome	274 Paraffin Dispenser
265 Cryostat Microtome	275 Slides Cabinet
266 Tissue Embedding Center	

Consumables



Automated Tissue Processor



Features:

- * 5.5-inch large LCD touch screen, real-time display of equipment working status.
- * Automatic drying function, intelligent control of hot air system, good drying effect, energy saving and durability.
- * The dyeing processing method can be customized, which can meet the requirements of various dyeing methods, various users, and various specimens.
- * Fully enclosed structure, environmentally friendly efflux air purification system, efficient treatment of toxic and harmful gases.

Technical Parameters:

Model	BK-TS1B
Cup Number	12pcs (9pcs reagent cup, 3pcs paraffin cup)
Tissue Protective Cup	7th cup
Single Cup Capacity	1100ml
Single Cup Processing Time	0-24h
Agitation Frequency	0-6times/min, adjustable
Dripping Time	0-60s, adjustable
Processing Basket Capacity	50pcs of dehydration cassette
Program Storage	8 sets
Noise	60dB(A)
Power	600W
Power Supply	Standard: 220V 50/60Hz, optional: 110V 50/60Hz
Packing Size	1250*650*700mm
Gross Weight	88kg

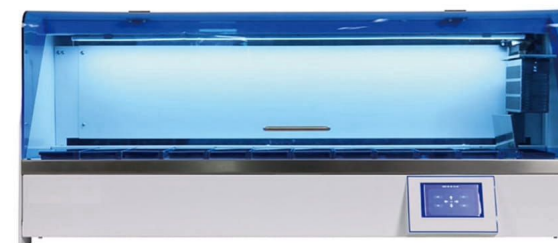

Features:

- * 5.5-inch large LCD touch screen, real-time display of the device working status
- * Rich man-machine dialogue interface, with online help function, easy to learn
- * Tank surface dripping time can be adjusted, reduce the chance of channeling, prolong the use of reagents, reduce pollution
- * Manual operation can be inserted at will, and automatically enter the original running state, convenient to check or add specimens during operation

Technical Parameters:

Model	BK-TS2B
Cup Number	12pcs (9pcs reagent cup, 3pcs paraffin cup)
Tissue Protective Cup	1-9th cup can be set
Single Cup Capacity	1800ml
Single Cup Processing Time	0-24h
Agitation Frequency	0-6times/min, adjustable
Dripping Time	0-59s, adjustable
Processing Basket Capacity	100pcs of dehydration cassette
Program Storage	8 sets
Noise	60dB(A)
Power	600W
Power Supply	220V 50/60Hz
External Size	1135*465*490mm
Net Weight	80kg
Packing Size	1320*610*650mm
Gross Weight	83kg

Manual Rotary Microtome



Features:

- * Blades and wax blocks can be placed in the groove on the top of the cover, which is easy to use.
- * Cross-roller guide rails to ensure long-lasting operation of the equipment.
- * High-precision micro-feeding system to achieve stable and high-precision slicing.
- * The wax block holder can be adjusted in any direction in three-dimensional space, which is easy and accurate to use.
- * The right wheel turns and stops immediately, and can be locked at any position to ensure the safety and convenience of slicing.
- * The counterweight design of the right runner makes slicing light and fast.
- * Precise tool holder lateral movement function, the position of the same sample changes very little after changing the blade edge, the base of the tool holder has a scale, which is convenient for the positioning of the tool holder.
- * The knife guard covers the full length of the blade to avoid the potential risk of injury during operation. When changing the blade, the ejector easily pushes the blade out and removes it safely.
- * Large-capacity removable waste chute, easy to clean.

Technical Parameters:

Model	BK-2258
Sectioning Thickness Range	0~60µm
Trimming Thickness Range	0~60µm
Mini. Sectioning Thickness	0.5µm
Precision	±5%
Max Specimen Size	50*70(mm)
Specimen Stroke	Horizontal:28mm, vertical:52mm
Tool Holder Stroke	The maximum forward and backward movement of the tool holder base is 60mm, and the maximum left and right movement of the tool holder is 23mm.
Sample Adjustment Direction	Horizontal 8° Vertical 8° Rotation 360°
External Size	570*462*295mm
Net Weight	29kg
Packing Size	600*580*530mm
Gross Weight	45kg



Introduction:

Microtome is used for sectioning thin and uniform tissue slices. The BK-2178 Microtome can section slices and trimmings between 0 and 60µm with a minimum adjustable index value of 0.5µm, which enables fast and accurate slicing operations. Equipped with a lengthening blade adapter and tool post to protect the safety of the operator and enable better tool retracting.

Features:

- * Precision cross-roller guide, equipped with stainless steel holder, to ensure long-lasting operation of the equipment.
- * Equipped with multi-angle adjustment device, easy to use. (Optional embedding chuck)
- * Magnetic removable waste chute, easy to clean.
- * Two-piece storage board, which can place blade embedding box and other related disposable items.
- * Large hand wheel double lock, and can be single-locked at any point, also double-locked at the highest point and any point, to ensure the safe exchange of knives and samples.

Technical Parameters:

Model	BK-2178
Sectioning Thickness Range	0~60µm
Trimming Thickness Range	0~60µm
Mini. Sectioning Thickness	0.5µm
Precision	±5%
Max Specimen Size	50*70(mm)
Specimen Stroke	Horizontal: 28mm, vertical: 52mm
Tool Holder Stroke	The maximum movement of the tool holder base is 60mm, and the maximum left and right movement of the tool holder is 23mm.
Sample Adjustment Direction	Horizontal 8° Vertical 8° Rotation 360°
External Size(L*W*H)	537x465x306(mm)
Net Weight	29kg
Packing Size(L*W*H)	660*590*600mm
Gross Weight	45kg

Semi-Automatic Microtome

Introduction:

Microtome is used for sectioning thin and uniform tissue slices. The BK-2238 Microtome can section slices between 0 and 100 μ m and and trimmings between 0 and 600 μ m with a minimum adjustable index value of 0.25 μ m, which enables fast and accurate slicing operations. Equipped with a lengthening blade adapter and tool post to protect the safety of the operator and enable better tool retracting.



Features:

- * Precision cross-roller guide, equipped with stainless steel holder, to ensure long-lasting operation of the equipment.
- * Equipped with multi-angle adjustment device and embedding chuck.
- * With sectioning/trimming, sectioning counting, retraction display(retraction range, feed travel of small hand wheel, feed direction of hand wheel) function.
- * Magnetic removable waste chute, easy to clean.
- * Two-piece storage board, which can place blade embedding box and other related disposable items.
- * Large hand wheel double lock, and can be single-locked at any point, also double-locked at the highest point and any point, to ensure the safe exchange of knives and samples.

Technical Parameters:

Model	BK-2238
Sectioning Thickness Range	0~100 μ m
Trimming Thickness Range	0~600 μ m
Retraction Range	0~200 μ m
Mini. Sectioning Thickness	0.25 μ m
Precision	\pm 5%
Velocity of Small Hand Wheel	100~1000 μ m, adjustable
Max Specimen Size	50 \times 70(mm)
Specimen Stroke	Horizontal: 28mm, vertical: 70mm
Tool Holder Stroke	The maximum movement of the tool holder base is 60mm, and the maximum left and right movement of the tool holder is 23mm.
Sample Adjustment Direction	Horizontal 8° Vertical 8° Rotation 360°
Power Supply	AC110/220V, 50/60Hz
Power	100W
External Size(L*W*H)	605x465x340(mm)
Net Weight	35kg
Packing Size(L*W*H)	725*590*590mm
Gross Weight	55kg

Automatic Microtome



Introduction:

Microtome is used for sectioning thin and uniform tissue slices. The BK-2228 Microtome can section slices between 0 and 100 μ m and and trimmings between 0 and 600 μ m with a minimum adjustable index value of 0.25 μ m, which enables fast and accurate slicing operations. Equipped with a lengthening blade adapter and tool post to protect the safety of the operator and enable better tool retracting.

Features:

- * Precision cross-roller guide, equipped with stainless steel holder, to ensure long-lasting operation of the equipment.
- * Equipped with multi-angle adjustment device, easy to use. (Optional embedding chuck)
- * Magnetic removable waste chute, easy to clean.
- * Two-piece storage board, which can place blade embedding box and other related disposable items.
- * Large hand wheel double lock, and can be single-locked at any point, also double-locked at the highest point and any point, to ensure the safe exchange of knives and samples.

Technical Parameters:

Model	BK-2228
Sectioning Thickness Range	0~100 μ m
Trimming Thickness Range	0~600 μ m
Retraction Range	0~200 μ m
Mini. Sectioning Thickness	0.25 μ m
Precision	\pm 5%
Max Specimen Size	50 \times 70(mm)
Specimen Stroke	Horizontal: 28mm, vertical: 70mm
Tool Holder Stroke	The maximum movement of the tool holder base is 60mm, and the maximum left and right movement of the tool holder is 23mm.
Sample Adjustment Direction	Horizontal 8° Vertical 8° Rotation 360°
Power Supply	AC110/220V, 50/60Hz
Power	150W
External Size(L*W*H)	600x495x340(mm)
Net Weight	39kg
Packing Size(L*W*H)	725*615*590mm
Gross Weight	60kg

Cryostat Microtome



Applications:

It is an essential product for rapid sectioning of pathological tissues, and is mainly suitable for quick frozen sectioning in large, medium and small hospitals, medical colleges, research institutes, animal husbandry, histology, pathology, forensic identification, etc.

Features:

- * This machine adopts a more reasonable structural design suitable for scientific research, clinical, large, medium, small, and hospital pathological frozen sections.
- * Four key cooling points are designed, all of which can be automatically adjusted according to the temperature required for slicing to ensure the speed and quality of slicing.
- * The mechanical parts of the slicer are all made of high-quality materials, precision processed and assembled, and the core is a closed structure, free of maintenance.
- * Knife feeding and retracting are electric control.
- * There is no need to turn on day and night, no need to pre-cool, and it will enter the frozen state within ten minutes after turning on.
- * The trimming thickness and slice thickness can be set by yourself.
- * It has two functions of automatic defrosting and manual defrosting.
- * Editing and slicing can be freely converted.
- * It has lighting and ultraviolet disinfection functions, and the freezer is equipped with a water pipe, which is convenient for cleaning.

Technical Parameters:

Model	BK-2328
Section Thickness Range	1-100µm
Trimming Thickness Range	10-400µm
Chamber Temp. Range	-10°C to -40°C
Specimen Head Temp. Range	-10°C to -40°C
Time to The Lowest Temperature	60min
Lowest Temp. of Refrigerating Table	-45°C
Lowest Temp. of Peltier Together with Refrigerating Table	-60°C
Max Specimen Size	55*60mm
Specimen Vertical Stroke	72mm
Specimen Horizontal Stroke	22mm
Electric Coarse Feed	Rapid 0.7mm/s, slow 0.35mm/s
Power Supply	Standard: 220V 50/60Hz, optional: 110V 50/60Hz
Power	500W
External Size	770*840*1190mm
Packing Size	850*940*1400mm
Gross Weight	165kg

Tissue Embedding Center

Features:

- * Fully automatic program control, can be preset to start on any day within a week
- * The temperature control adopts a single-chip microprocessor controller, and the temperature setting is simple
- * Using a new type of heating element, fast heating, uniform heating, energy saving and reliable
- * Double overheating protection device, safe and reliable
- * With memory function, automatically retain the preset temperature after operation
- * Novel appearance, split design, embedding machine, freezing table, random combination
- * Enlarging the left and right boxes, suitable for all kinds of dehydration baskets, the inner and outer boxes are separated, easy to clean and maintain
- * Equipped with a metal hose magnifying glass, it is suitable for very small sample tissue operations



Technical Parameters:

Model	BK-TEV
Thermal Temperature Range	RT-80°C
Control Temperature Precision	±3°C
Timing Range	0-24h
Paraffin Chamber Size	650*130*97mm
Thermal Storage Size	240*240*57mm, two pcs
Working Area Size	700*93mm
Power	≤1100W
Power Supply	Standard: 220V 50/60Hz, optional: 110V 50/60Hz
Machine Size	672*735*383mm
Net Weight	41kg
Packing Size	875*830*535mm
Gross Weight	50kg

Tissue Embedding Center

Features:

- * Environmentally friendly fluorine-free refrigerant is selected, with low noise and fast cooling effect
- * The temperature control adopts a single-chip microprocessor controller, and the temperature setting is simple
- * With temperature control mode and super cooling mode, high temperature control accuracy
- * The cooling temperature can be adjusted to achieve the ideal cooling effect

Technical Parameters:

Model	BK-CPIV
Temperature Control Range	5 to -20°C (Max to -28°C)
Control Temperature Precision	±1°C
Working Area Size	360*300mm
Power	300W
Power Supply	Standard: 220V 50/60Hz, optional: 110V 50/60Hz
Machine Size	630*350*400mm
Net Weight	23kg
Packing Size	785*490*490mm
Gross Weight	36kg



Remark: The above two products should be used together.

Tissue Embedding Center

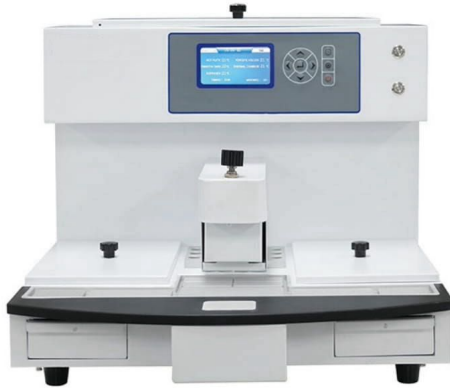

Features:

- * Fully automatic program control, can be preset to start any day within a week.
- * The temperature control adopts a single-chip microprocessor controller, and the temperature setting is simple.
- * Using a new type of heating element, the heating is fast, the heating is uniform, and the energy saving is reliable.
- * Equipped with a small cooling platform, the base mold paraffin can be quickly pre-cooled.

Technical Parameters:

Model	BK-TEI
Thermal Temperature Range	55-80°C
Control Temperature Precision	±3°C
Timing Range	0-24h
Paraffin Chamber Size	350*145*67mm
Thermal Storage Size	205*145*60mm, two pcs
Working Area Size	500*145mm
Power	1000W
Power Supply	Standard: 220V 50/60Hz, optional: 110V 50/60Hz
Packing Size	640*640*660mm
Gross Weight	43kg

Tissue Flotation Water Bath & Slide Dryer



Applications:

It is suitable for medical diagnosis, biological research, epidemic prevention, forensic identification.

Features:

- * Integrating spreading, baking and roasting slices in one, compact structure (small space occupation), novel shape and easy operation.
- * The film drying box can dry the film at a constant temperature and can accommodate 3 dyeing racks.
- * The louver-style grilling table top has a large capacity (60 slides are actually arranged), easy to put and take out, and the grilling effect is better.
- * High-brightness LCD display, real-time display of sheet spreading and drying sheet temperature, simple and clear.
- * Highly sensitive temperature control integrated unit, high precision and reliable performance.
- * With over-temperature alarm function.
- * Using new heating software, fast heating, uniform heating, small thermal inertia, reliable energy saving.
- * With memory function, automatically retain the set temperature after operation.
- * The work surface is spray-coated, corrosion-resistant.

Technical Parameters:

Model	BTH-VI
Temperature Range	RT~90°C
Temperature Precision	±2°C
Over Temperature Alarm Range	1~5°C
External Size	590*340mm*180mm
Water Tank Size	220*150mm*65mm
Drying Plate Size	260*150mm
Oven Size	200*100*110mm
Power	≤650 W
Power Supply	Standard: 220V 50/60Hz, optional: 110V 50/60Hz
Packing Size	650*410*240mm
Gross Weight	12.3kg

Tissue Flotation Water Bath & Slide Dryer



Applications:



Medical Diagnosis

Biological Research

Epidemic Prevention

Forensic Identification

Features:

- * It integrates spreading and drying, compact structure (small footprint), novel shape and easy operation.
- * The louver-type drying table has a large capacity (actually arranges 60 slides), is easy to put and take out, and has a better drying effect.
- * High-brightness LCD display, real-time display of sheet spreading and drying sheet temperature, simple and clear.
- * Highly sensitive temperature control integrated unit, high precision and reliable performance.
- * With over-temperature alarm function.
- * Using new heating software, fast heating, uniform heating, small thermal inertia, reliable energy saving.
- * With memory function, automatically retain the set temperature after operation.
- * The work surface is spray-coated, corrosion-resistant.

Technical Parameters:

Model	BTH-V
Temperature Range	RT~90°C
Temperature Precision	±2°C
Over Temperature Alarm Range	1~5°C
External Size	500*330mm*180mm
Water Tank Size	220*150mm*65mm
Drying Plate Size	260*150mm
Power	≤450 W
Power Supply	Standard: 220V 50/60Hz, optional: 110V 50/60Hz
Packing Size	560*395*220mm
Gross Weight	10kg



Features:

- * Integrate tissue flotation water bath and slide dryer, compact structure and easy operation
- * High-brightness LCD display, real-time display of temperature.
- * Highly sensitive temperature control integrated unit, high precision and reliable performance.
- * With over-temperature alarm function
- * Using new heating materials, heating fast, uniform heating, low thermal inertia, energy saving and reliable.
- * With memory function. The set temperature is automatically retained.
- * Louver-type drying table, easy to operate, better drying effect
- * The work surface is sprayed for corrosion resistance.

Technical Parameters:

Model	BTH-I
Temp. Range	RT to 90°C
Temp. Precision	2°C
Environmental Temp. Range	0~40°C
Over-Temp. Alarm Range	1~5°C
Drying Area	344*260mm
Bath Tank Size(W*D*H)	304*207*52mm
Display	LCD
Power Supply	AC220V±10%, 50/60Hz; AC110V±10%, 60Hz
Consumption	600W
External Size(W*D*H)	695*400*210mm
Package Size(W*D*H)	800*510*320mm
Gross Weight	20kg

Tissue Flotation Water Bath



Features:

- * High-brightness LCD display, real-time display of temperature.
- * Highly sensitive temperature control integrated unit, high precision and reliable performance.
- * With over-temperature alarm function
- * Using new heating materials, heating fast, uniform heating, low thermal inertia, energy saving and reliable.
- * With memory function. The set temperature is automatically retained.
- * The work surface is sprayed for corrosion resistance.

Technical Parameters:

Model	BT-I
Temp. Range	RT to 99°C
Temp. Precision	±1°C
Over-temp. Alarm Range	1~5°C
Environmental Temp. Range	0~40°C
Bath tank Size(W*D*H)	240*180*55mm
Display	LCD
Power Supply	AC220V±10%, 50/60Hz(Standard); AC110V±10%, 60Hz(Optional)
Consumption	200W
External Size(W*D*H)	345*340*130mm
Package Size(W*D*H)	410*410*220mm
Net Weight	5kg
Gross Weight	6kg

Slide Dryer (Hot Plate)



BH-I



BH-II

Features:

- * High-brightness LCD display, real-time display of temperature.
- * Highly sensitive temperature control integrated unit, high precision and reliable performance.
- * With over-temperature alarm function
- * Using new heating materials, heating fast, uniform heating, low thermal inertia, energy saving and reliable.
- * With memory function. The set temperature is automatically retained.
- * The work surface is sprayed for corrosion resistance.
- * Louver table, 65°inclination Angle, large capacity. (Only for BH-II)

Technical Parameters:

Model	BH-I	BH-II
Temp. Range	RT to 90°C	
Temp. Precision	±1°C	
Environmental Temp. Range	0~40°C	
Over-temp. Alarm Range	1~5°C	
Drying Area	345*260mm	
Number of Slides	40	70
Display	LCD	
Power Supply	AC220V±10%, 50/60Hz(Standard); AC110V±10%, 60Hz(Optional)	
Consumption	200W	
External Size(W*D*H)	345*340*130mm	
Package Size(W*D*H)	410*410*200mm	
Net Weight	5kg	
Gross Weight	6kg	

Automated Tissue Stainer



Features:

- * 5.5-inch large LCD touch screen, real-time display of equipment working status.
- * Automatic drying function, intelligent control of hot air system, good drying effect, energy saving and durability.
- * The dyeing processing method can be customized, which can meet the requirements of various dyeing methods, various users, and various specimens.
- * Fully enclosed structure, environmentally friendly efflux air purification system, efficient treatment of toxic and harmful gases.

Technical Parameters:

Model	BK-RS1A
Cup Number	14pcs (1st is drying cup, 8th is washing cup)
Single Cup Capacity	1200ml
Each Cup Processing Time	0-59min
Dripping Time	0-30s
Slides Capacity	72pcs
Program Storage	8 sets
Noise	60dB(A)
Power	1000W
Power Supply	Standard: 220V 50/60Hz, optional: 110V 50/60Hz
Packing Size	1450*700*750mm
Gross Weight	100kg

Paraffin Dispenser



Features:

- * The LCD screen displays the heating status.
- * Adopt new heating element, heating fast, energy saving and reliable.
- * Paraffin valve intelligent control heating control, to ensure smooth wax.
- * Imported temperature measuring integrated block, high precision, stable performance.
- * With memory and automatic recovery function, automatically save preset temperature after running.
- * Full computer automatic control program, intelligent digital temperature controller, real-time temperature display.

Technical Parameters:

Model	BK-RLY
Capacity	12L
Temp. Range	RT~100°C
Temp. Precision	±1°C
Consumption	1000W
Power Supply	Standard: 220V 50/60Hz, optional: 110V 50/60Hz
External Size	330*430*550mm
Net Weight	15kg
Packing Size	440*560*700mm
Gross Weight	27kg

Slides Cabinet



Technical Parameters:

Model	BKC-S400	BKC-PB450	BKC-SS450
Capacity	72 Drawers (12 layers*6 grid, plus a base) Loading: 760*72=54720 pcs glass slides	18 Drawers (3 layers*6 grid, plus a base) Loading: 12000 pcs paraffin block	18 Drawers (3 layers*6 grid, plus a base) Loading: 4536 or 9072 pcs glass slides
Material	Cabinet	Cold-rolled steel plate. Surface Treatment: Degrease oil, Table regulator, Zinc parkerising, Passivation, Powder spraying	
	Drawer	Specialized slide drawer, ABS slide plate	
	Slot	Made by special mold	
	Mark Groove	Integration forming	
External Size(W*D*H)	403*478*1625mm	450*478*1295mm	450*478*1295mm
Package Size(W*D*H)	490*590*430mm, 3pcs; 490*590*555mm, 1pcs;	530*570*440 mm,3pcs; 530*570*565mm, 1pc	530*570*440 mm, 3pcs; 530*570*565mm, 1pc
Gross Weight	32kg, 3pcs; 36kg, 1pc	29kg, 3pcs; 33kg, 1pc	27kg, 3pcs; 31kg, 1pc

Blood Bank Instrument Blood Collection Chair

Features:

- * Manual or electric control type for your choice.
- * Made of high-strength fiber material and poly-layer paint, more durable, easy to clean.
- * Designed with people-oriented idea, to meet the donor's sense of security and comfort, to alleviate the psychological pressure, to ensure an easier and enjoyable process.
- * Mattress using a high-quality medical polyurethane foam molding leather, easy for clean and maintenance, anti-static and anti-fouling properties superior to other similar products.



Technical Parameters:

Model	BK-BC100	BK-BC100A
Seat Section Size(mm)	1800*580	
Seat Section Height(mm)	480	
Backing Board Turning Angle	0~70°	
Chair Backward and Forward Tilt Angle	8°~15°	
Leg Plate Turning Angle	0~90°	
Handrail Swing Out Angle	0°~45°	
Handrail's Moving Distance	100mm	
Handrail Board Size	500*160mm	
Lifting Speed	/	3~25mm/s
Power Supply	/	AC110/220V±10%, 50/60Hz
Reading Lamp Power	/	60W
Standard Accessories	Hand operation, handrail rack, small table	
Optional Accessories	LED hose-type reading lamp; movable assistant desk; soft velvet cover	
Load Capacity	220kg	
Packing Size(W*D*H)	1500*780*600mm	
Gross Weight	65kg	75kg

Blood Collection Monitor

Introduction:

Blood collection monitor has the functions of weighing, zero point calibration, fluid collection control, oscillation and so on. It is an ideal equipment for blood collection, which is suitable for blood centers, blood stations, hospitals and other blood collection and supply units.



Features:

- * Microcomputer control is adopted to realize the integration of weighing and collecting liquid.
- * Built-in large capacity lithium battery, long battery life.
- * With automatic sound and light alarm function, when the amount of liquid reaches the predetermined value or the predetermined time, the alarm prompts.
- * The gentle swing mode is safer for platelets and red blood cells that are easily damaged in the blood.
- * Using new type of weighing sensor, weighing more accurate.
- * Constant speed motor, low noise, long service life.
- * The liquid collection digital display is displayed in milliliters without calculation and conversion, which is more convenient and convenient to use.

Technical Parameters:

Model	BCM-4
Measuring Range	400ml
Resolution	2ml
Liquid Proportion	1.05g/ml
Collection Speed	0.5-3ml/s
Static Error	±2g
Swing Frequency	30r/min
Alarm	Collection finish, Automatic sound and light dual alarm
Ambient Temperature	5°C~40°C
Battery	Lithium battery, 12V,5000mAh, 3 hours of battery life
Power Supply	100~240V, 50/60Hz
External Size(W*D*H)	226*170*158mm
Net Weight	2.1kg
Packing Size(W*D*H)	330*190*180mm
Gross Weight	3.1kg



BCM-12A



BCM-12B

Features:

- * Unique modern sensor and LED display.
- * Preset volume of blood collection function.
- * Taring and calibrating function, ensure measuring accuracy.
- * Soft shaking mode, improving the survival of effective components in the blood.
- * Shaking auto stops when bags are taken away during collection and restart working after bags are remounted.
- * If collection volume is preset, the balance will stop shaking when there is 10ml gap and get into accurate measuring status.
- * Automatic alarm when reaching the preset value.
- * Humanization design and reasonable structure is convenient for operation.

Technical Parameters:

Model	BCM-12A	BCM-12B
Measuring Range	0~1200ml	
Measuring Accuracy	2%	
Display Accuracy	1ml	
Liquid Proportion	1.05g/ml	
Collection Speed	0.5~3ml/s	
Swing Frequency	30~32 r/min	
Swing Angle	13±2°	
Alarm	Audio and visual alarm	Audio and visual alarm with interrupter
Interrupter Thrust	/	≤14N
Consumption	12W	40W
Power Supply	AC110/220V±10%, 50/60Hz	
External Size(W*D*H)	218*172*160mm	275*230*210mm
Packing Size(W*D*H)	310*260*210mm	330*280*260mm
Net/Gross Weight	2.8kg/3.5kg	4.2kg/5.5kg

High Frequency Heat Sealer

Feature:

- * Instant heat, uniform heat, reliable adhesion, no pollution.
- * It can be applied to pipelines up to 6mm, and the heat sealing time is controlled accurately and the heat sealing thickness is unified.
- * Automatic control of thermal sealing mode, increase the convenience of equipment.
- * Unique design, with high frequency protection function, safe use.



Technical Parameters:

Model	BJPX-PR
Output Voltage	220±10% ,50Hz±1Hz, three-levels adjustable
Sealing Type	Automatic
Sealing Time	0.5~4s
Tube Diameter	Outer diameter φ3mm~φ6mm, δ≤1mm (thickness) infusion tube
Power Supply	AC220V±10%, 50/60Hz
Power Consumption	360W
External Size (mm)	302*172*203
Packing Size (mm)	420*260*400
Net Weight (kg)	7.5
Gross Weight (kg)	8.5

Blood Plasma Extractor



Applications:

It is used to extract blood components from centrifuge bags. It is widely used in hospitals, blood stations, etc. After the plasma in the blood bag is stratified, the pressure of the plasma extractor can squeeze out different components of the blood from top to bottom.

Features:

- * Manual separation, easy to operate.
- * Using a transparent splint, it is easy to observe the separation of plasma and red blood cells.
- * The body is made of 304 brushed stainless steel, which is beautiful and easy to clean and disinfect.

Technical Parameters:

Model	BJPX-FJ
Body Material	Stainless Steel
Clamping Force	≥20N
Applicable Blood Bag	100ml,200ml,300ml,400ml
Net Weight	2.5kg
External Size	170*280*250mm
Packing Size	380*260*290mm
Gross Weight	3.5kg

Low Temperature Blood Operating Bench



Introduction:

The Blood low-temperature workstation are adopts microcomputer control, real-time temperature digital display, convenient functional parameter setting, automatic constant temperature.It is widely used in blood transfusion departments and clinical blood transfusion to provide a suitable blood matching environment and avoid cross infection.

Features:

- * The scientific and reasonable design of the operating countertops can effectively avoid the blood sample slipping off the table.
- * Using microcomputer precision temperature control technology, high temperature control precision, real-time digital display table temperature, with ultra-low temperature alarm, convenient parameter setting.
- * Product countertops is made of high quality stainless steel wire drawing process, appearance beautiful, use more convenient clean.
- * Equipped with leakage current and over voltage protector.
- * The compressor has the function of delay starting and high temperature protection.

Technical Parameters:

Model	BJPX-PD
External Size (W*H*D) mm	1350*860*880
Internal Size (W*H*D) mm	1310*20*820
Display	Touch Display
Temp.Range	2-8°C
Temp.Fluctuation	±0.1°C
Refrigeration Type	Air cooling
Consumption	1800W
Power Supply	AC220±10%, 50/60HZ
Net Weight (kg)	130
Gross Weight (kg)	150

Blood Thaw Machine

Introduction:

Blood Thaw Machine is suitable for blood centers, clinical transfusion departments, hospitals, blood products production units, using microcomputer control, temperature digital display, arbitrary setting, automatic constant temperature, swing function. Widely used for the rapid melting of frozen blood components and biological products. Applicable to hospital blood testing department, blood centers, blood banks and other industries.



Features:

- * High definition touch screen, sensitive operation.
- * Real-time temperature curve display.
- * Traceability management system, real-time record storage temperature data in the melting process.
- * A variety of thawing modes are available to adapt to thawing and rewarming of frozen plasma, platelets and blood products with different volumes.
- * Double circulation system, more constant temperature in the melting process, effectively eliminate the precipitation of fibrin, protect the active components of plasma.
- * Disintegrated water tank, convenient for regular deep cleaning and disinfection of equipment.
- * Equipped with a code scanning device, which can scan and record the thawing data of each bag of plasma, including thawing start and end date, time, and temperature data information during thawing.(Optional)
- * Standby automatic water refill, one key cleaning function, with temperature and water level protection function. (Only for BJPX-PT12 and BJPX-PT24)
- * Dual use of one machine to realize the fast switching between dry and wet thawing. (Only for optional isolated water type)
- * The waterproof bag is made of medical composite material, which ensures the thermal conductivity of the thawing bag and the contact area between the thawing bag and the plasma bag. (Only for optional isolated water type)

Technical Parameters:

Model	BJPX-PT6	BJPX-PT12	BJPX-PT24
Thawing Type	Standard: Water bath type Optional: Isolated water type		
Temp. Range	37.0±3.0℃		
Temp. Resolution	±0.1℃		
Water Storage Capacity	20kg±5%	58kg±5%	98kg±5%
Max Thawing Quantity	6pcs	12pcs	24pcs
Thawing Time	10~15min		
Ambient Temp.	18℃~30℃		
Consumption	1000VA	2000VA	3600VA
Power Supply	AC220V 50/60Hz		
External Size	550*500*470mm	600*540*970mm	720*600*990mm
Package Size	670*620*695mm	744*714*1200mm	860*745*1210mm
Net Weight	25kg	55kg	80kg
Gross Weight	42kg	75kg	105kg



Introduction:

BJPX-PT8 is suitable for blood centers, clinical transfusion departments, hospitals, blood products production units, using microcomputer control, temperature digital display, arbitrary setting, automatic constant temperature, swing function. It is widely used for the rapid melting of frozen blood components and biological products.

Features:

- * Special shape design of main control panel, easy to observe, control, ergonomic.
- * Microcomputer PID precision temperature control technology, high temperature control precision.
- * Digital display temperature, swing frequency, time.
- * The liner is made of high quality rust-proof wire drawing stainless steel.
- * Configuration of leakage current, overvoltage protector.
- * With overtemperature alarm, the temperature in the box exceeds the set temperature 1℃ will start the alarm.
- * Independent overtemperature control system design, with double protection function, to ensure the safety of use.

Technical Parameters:

Model	BJPX-PT8
Display	Touch screen
Temp. Range	37.0±3.0℃
Temp. Resolution	±0.1℃
Thawing Quantity	3 layers(1~12pcs)
Swing Frequency	60±5 times/min or Automatic frequency modulation
Swing Mode	Continuous left and right reciprocating, horizontal swing
Ambient Temp.	18℃~30℃
Power Supply	AC220±22V, 50/60Hz/ 2100VA
Internal Size	298*238*233mm
External Size	832*558*498mm
Package Size	935*665*665mm
Net Weight	60kg
Gross Weight	80kg

Note: The relevant data were measured when the ambient temperature was 25℃ and the relative humidity was less than 85%.

Manual Medical Sealer

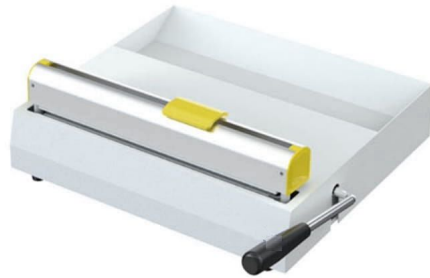

Features:

- * Carbon steel spray-coated housing, aluminum alloy pressure plate, high temperature resistance, aging resistance, long service life.
- * Equipped with a long pressing handle, more labor-saving.
- * With temperature adjustment function, it can adapt to different packaging materials.
- * With over-temperature protection function.
- * Adopt high-quality alloy blades, cutting is smooth and flat.
- * The effective sealing packaging bag width can reach 280mm.

Technical Parameters:

Model	MS-H1
Shell Material	Carbon steel spray
Accessories Material	Aluminum alloy, 304 stainless steel
Heat Sealing Temperature	60~220°C, can be adjustable
Seal Width	10mm
Seal Method	Manual pressing
Input Power	300W
External Size	370*300*130mm
Power Supply	Standard: 220V 50/60Hz, optional: 110V 50/60Hz
Net Weight	5.0kg
Packing Size	440*390*170mm
Gross Weight	6kg

Automatic Medical Sealer



MS-10



MS-30P

Features:

- * Automatic fast continuous heat sealing technology is adopted to improve the packaging efficiency
- * High temperature ceramic plate is adopted, which heats up quickly, heats evenly, can be dry-burned, and has a long service life
- * Intelligent temperature control temperature is adjustable from room temperature to 220°C, and the working temperature is accurately controlled by $\pm 1^\circ\text{C}$
- * It has a fault prompt function, which can monitor the operation of the machine in real time during operation
- * The floating constant pressure pressing system design is suitable for the sealing needs of high and low temperature sterilization packaging bags, paper-plastic three-dimensional bags and paper-paper bags
- * Printing function for model MS-30P

Technical Parameters:

Model	MS-10	MS-30P
Shell Material	Casing carbon steel spray-coated	Casing carbon steel spray-coated
Accessory Material	Aluminum alloy, 304 stainless steel	Aluminum alloy, 304 stainless steel
Heat Sealing Temperature	RT~220°C, can be adjustable	RT~220°C, can be adjustable
Sealing Width	12mm	12mm
Sealing Speed	$\geq 10\text{m}/\text{min}$	$\geq 10\text{m}/\text{min}$
Sealing Margin	0~40mm	0~40mm
Screen	Digital tube display	7-inch color touch screen
Control System	/	Industrial system
Printing System	/	Printing module can be ejected from the side to replace the ink cartridge
Printing Mode	/	Needle type, single line
Information Export	/	USB
Input Power	400W	400W
Power Supply	Standard: 220V 50/60Hz, optional: 110V 50/60Hz	
External Size	540*240*188mm	540*240*188mm
Net Weight	11kg	11kg
Packing Size	625*325*270mm	625*325*270mm
Gross Weight	15kg	16kg

Automatic Medical Sealer

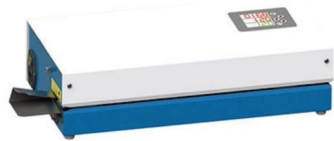

Spray carbon steel



304 stainless steel

Features:

- * Auto-control function, continuous operation; substitution of manual sealing machine;
- * Microcomputer Temperature controller, accuracy $\pm 1\%$, working temperature range 60~220°C;
- * Fast heating, 40 seconds required from room temperature to 180°C;
- * Adjustable fixed-force system, suitable for sealing paper-plastic bags, 3D paper-plastic bags and paper-paper bags;
- * Advanced flat ceramic heating components, high-temperature stability, long life expectancy and high heat efficiency.

Technical Parameters:

Model	MS100-L
Seal Speed	10m/min
Seal Width	12mm
Seal Margin	0~35mm adjustable
Display	LED screen
Machine Shell Material	Spray carbon steel(standard) or 304 stainless steel(optional)
Consumption	500W
Power Supply	AC110/220V $\pm 10\%$, 50/60Hz
External Size (W*D*H)	490*240*120mm
Packing Size (W*D*H)	600*380*260mm
Net/Gross Weight	11/12kg

Printing Medical Sealer

Features:

- * Temperature controlled by a microcomputer, accuracy $\pm 1\%$, working temperature range is 60~220°C;
- * Automatic fault detection and alarm;
- * Fast heating, 40 seconds required from room temperature to 180°C;
- * Automatic temperature reduction operated by a fan connected to temperature control system, reducing the waiting time;
- * Adjustable fixed-force system, suitable for sealing 3D paper-plastic bags and paper-plastic bags of any sickness;
- * Advanced flat ceramic heating components, high-temperature stability, long life expectancy and high heat efficiency.

MS101-PD

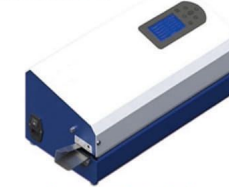

Spray carbon steel

MS101-T

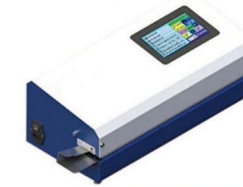

Spray carbon steel

MS101-T1/TT



Spray carbon steel

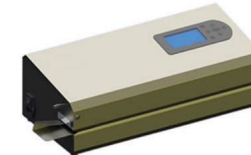

304 stainless steel

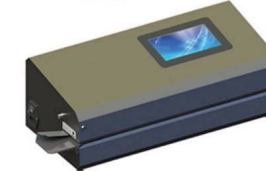

304 stainless steel



304 stainless steel

Printing System Features:

- * Print function can be disabled or partially activated;
- * Sterilizing and expire date auto adjust; Automatic faults alarm display during working;
- * Adjustable character font and style, easy to print more information on narrower bags;
- * The system provides the required minimum width of the bag based on the content of print, easier for users to define the print content or select appropriate bag; Auto alarm when width is insufficient;
- * With sealing detection mode;

Technical Parameters:

Model	MS101-PD	MS101-T	MS101-TT
Seal Speed	10m/min		
Seal Width	12mm		
Seal Margin	0~35mm adjustable		
Display	4.3" color LCD screen	7" color LCD touch screen	
Machine Shell Material	Spray carbon steel(standard) or 304 stainless steel(optional)		
Other Functions	/	/	Double line printing
Consumption	500W		
Power Supply	AC110/220V $\pm 10\%$, 50/60Hz		
External Size (W*D*H)	560*260*220mm		
Packing Size (W*D*H)	670*360*340mm		720*360*340mm
Gross Weight	19kg		22kg

Pharmacy Instrument

Disintegration Tester

Disintegration tester is used for detecting disintegration of solids under prescriptive conditions.



Features:

- * Auto-diagnose, auto-alarm.
- * Stainless steel basket and paddle.
- * Micro processor and LCD Display.
- * Each beaker can work alone.
- * Water circulating in the bath to keep the temperature conformity with magnetic pump.

Technical Parameters:

Model	BK-BJ1	BK-BJ2	BK-BJ3	BK-BJ4
Basket	1pc	2 pcs	3 pcs	4 pcs
Beaker Capacity	1000ml			
Basket Lifting Frequency	30~31 times/min			
Stroke Height	55±1mm			
Minimum Spacing	25±2mm			
Mesh Size	Standard 2mm			
Temp. Range	RT~50°C			
Temp. Precision	±0.3°C			
Timing Range	1~900min			
Time Precision	±0.5min			
Working Time	>24h			
Power Consumption	600W			
Power Supply	AC220V/110V±10%, 50/60HZ			
External Size (W*D*H) mm	260*300*440	400*320*440	540*320*440	600*320*440
Package Size (W*D*H) mm	360*400*530	500*395*530	640*400*530	700*400*530
Gross Weight (kg)	12	18.5	23	28

Dissolution Tester

Dissolution tester is used for detecting pharomic dissolution from tablet, capsule etc. in prescriptive menstruum.



Features:

- * Auto-diagnose, auto-alarm.
- * Stainless steel basket and paddle.
- * Micro processor and LCD Display.
- * The head part of the instrument can be turned over smoothly and flexibly(Rise and fall for BK-RC8).
- * Water circulating in the bath to keep the temperature conformity with magnetic pump.

Technical Parameters:

Model	BK-RC1	BK-RC3	BK-RC6	BK-RC8
Basket	1 pc	3 pcs	6 pcs	8 pcs
Speed Range	20~200rpm			
Speed Precision	±2rpm			
Temp. Range	RT +45.0°C			
Temp. Precision	±0.3°C			
Timing Range	5~900min	5~900min	1~999min	1~999min
Time Precision	±0.5min			
Working Time	>24h			
Paddle Swing Amplitude	±0.5mm			
Basket Swing Amplitude	±1.0mm			
Power Consumption	600W	600W	1200W	1200W
Power Supply	AC110/220V±10%, 50/60Hz			
External Size(W*D*H)mm	260*300*480	510*300*480	960*320*480	680*540*480
Package Size (W*D*H)mm	490*395*560	750*400*565	1210*440*550	850*615*745
Gross Weight(kg)	18.5	30	44	74

Tablet Friability Tester

It is used for detecting friability/abrasion of tablet.



Features:

- * Automation: auto-test, auto-diagnose, auto-alarm.
- * Intelligently control the rotating speed of cylinder and revolutions.
- * One drum runs synchronously. Auto stop at timing point. (only for TFT-4)
- * Single path and double cylinder, synchronous operation and automatic stop.
- * The revolution of the drum can be preset at any time, either preset or real data is displayed on the LCD.
- * Microprocessor unit is used to control all operations, high accuracy is achieved in testing rotary speed and circle number.

Technical Parameters:

Model	TFT-1	TFT-2	TFT-3	TFT-4
Cylinder Number	2			1
Cylinder Radius	Φ286			
Cylinder Depth	39mm			
Tablet Fall Height	156mm			
Rotating Speed	20~100rpm	25rpm		
Rotation Count	5~900 turns	100 turns	5~900 turns	10-900 turns
Consumption	40W	20W		50W
Power Supply	AC110/220V±10%, 50/60Hz			
External Size(W*D*H)mm	370*300*340			300*200*340
Package Size(W*D*H)mm	440*400*525			410*295*430
Gross Weight(kg)	12			8

Tablet Hardness Tester

Tablet hardness tester is used to measure the crushing hardness of tablets.



Features:

- * LCD Display. High-precision pressure sensor ensures the precision and reproducibility of test.
- * Easy operation: Manual loading and manual tablet compressing for THT-1, manual single tablet and automatic continuation for THT-2/3.
- * Automatic display, automatic latching, automatic reset, automatic cycle test, automatic linear error correction and automatic fault diagnosis.
- * Unit conversion function, can realize the conversion before or after the tests.
- * Strong data processing ability; statistics, analysis, printing and display are available for test result. (only for THT-2)
- * Built-in printer. (only for THT-2)

Technical Parameters:

Model	THT-1	THT-2	THT-3
Test Range	2~200N(0.2~20kg)	2~200N/500N(0.2~20kg) Customize: 2~500N(0.2~50kg)	
Resolution	0.1N 0.01kg		
Accuracy	±0.5%		
Probe Procession Range	2~20mm	2~40mm	
Consumption	10W	40W	
Power Supply	AC110/220V±10%, 50/60Hz		
Dimensions(W*D*H)mm	280*180*110	500*400*160	400*240*140
Package Size(W*D*H)mm	420*300*230	600*350*250	500*350*250
Gross Weight(kg)	6	12	10

Thaw Tester

BTT-1 and BTT-4B thawing time limit tester is used to inspect the condition of thawing, softening or dissolution of solid preparations such as suppositories or vaginal tablets under the prescribed conditions.



BTT-1



BTT-4B

Features:

- * LCD Display
- * Three-beaker, three-path, three-path synchronization. Manual overturn for BTT-1, automatic overturn for BTT-4B.
- * Transparent sleeve, stainless steel net racks.
- * Automatic temperature control, automatic time keeping.
- * Timing overturn indication forecast and fault alarm. (only for BTT-4B)
- * Magnetic water pump circulating water flow uniform heat system is adopted, and bath temperature is uniform.
- * Double-functional head which can lift and descend electrically and turn over manually. (only for BTT-4B)

Technical Parameters:

Model	BTT-1	BTT-4B
Number of Sleeve	3 pieces	
Hyaline Sleeve Inner Size	Φ52*H60mm	
The Net Frame of Stainless Steel	2 pieces/diameter 50mm/each 39 holes of 4mm	
Automatic Time Range	10~900min	
Time Precision	±0.5min	
Temperature Control Range	20~45°C	
Temperature Control Precision	±0.5°C	
Volume of Beaker	5L*3	
Power Supply	AC110/220V±10%, 50/60Hz	
Package Size(W*D*H) mm	770*510*830	750*480*850
Gross Weight(kg)	45	64

Tablet Four-usage Tester

Four function: test hardness of tablet, friability/abrasion, disintegration and dissolution rate. It is a very ideal multi-purpose drug test instrument.

Features:

- * Auto-control, auto-detection, auto-diagnosis and auto-alarm.
- * Auto-temperature control and high temperature control precision.
- * Auto-time control and auto-timing shutdown.
- * Auto-display, auto-latching, auto-reset and auto-cyclic test.
- * Automatic control of friability and high control precision for cylinder rotation speed and number of turns.
- * Hardness high-precision pressure sensor, digital display of hardness value.
- * Continuous measurement of tablet hardness value, manual tablet feeding, motor control and automatic compression.
- * Two-path disintegration operates at the same time, automatic timing shutdown.
- * Imported SUS316 stainless steel is adopted for dissolution rotation baskets and paddle rods, etc.



Technical Parameters:

Model	TFUT-3
Temperature Range	(20~40°C)±0.3°C
Speed Range	(20~200rpm)±2rpm
Automatic Time Range	(1~900min)±0.5min
Stations of Dissolution	3
Paddle Radial Run-out	±0.5mm
Basket Radial Run-out	±1.0mm
Basket Assemblies	2
Nacelle Back and Forth Frequency	(30~32)times/min
Nacelle Back and Forth Range	(55±2)mm
Drum	1
Drum's Inner Size	Φ286*H39mm
Tablet Fall Height	156mm
Rotating Speed	(25±1)times/min
Rotating Count	(100±1)turns
Hardness Range	(25~199)±1N
Diameter Range	(3~40)mm
Power Supply	AC110/220V±10%, 50/60Hz
Dimensions(W*D*H)mm	520*380*470
Packing Size(W*D*H)mm	700*440*680
Gross Weight(kg)	45

Clarity Tester

It tests clarity of injection and bottled medicine liquid.



CT-1



CT-2

Features:

- * Flash eliminated. Illumination is adjustable.
- * Time and alarm automatically. Test continuously.
- * CT-1 is one side for one operator. CT-2 are two sides for two operators.
- * The three-primary-color fluorescent lamp is controlled by good lighting sensor, electronic inductor and shading.

Technical Parameters:

Model	CT-1	CT-2
Lamp	Three-primary-color fluorescent lamp	
Illumination Range	1000~6000LUX	1000~4000LUX
Time Range	1~99s	
Consumption	40W	
Power Supply	AC110/220V±10%, 50/60Hz	
Package Size(W*D*H) mm	735*260*595	735*520*595
Gross Weight(kg)	14	20

Gel Strength Test System



Gel strength test system is mainly used to measure the gel strength of gelatin under the stipulated environment. It consists of: 1. Gel Strength Tester; 2. Constant Temperature Bath; 3. Refrigerator.

Features:

- * High-definition LCD Display.
- * Powerful data processing ability. submit mean value, final value or peak value automatically.
- * Four kinds of sampling measurement modes: single-step, maintaining, circulating and automatic.
- * Automatic measurement mode can help you obtain the value of gel strength faster, more accurately and more realistically.
- * 5 kinds of sampling speeds: 0.1mm/s, 0.2mm/s, 0.5mm/s, 1mm/s and 2mm/s.
- * Sampling depth can be preset arbitrarily (1~60mm).
- * Professional high-precision pressure sensor.
- * High-precision mechanical drive matches with 4-class shockproof design.
- * Automatic correction of non-linear error, automatic fault diagnosis alarm, automatic outrange protection and automatic error correction prompt.
- * Embedded micro printer, standard serial printing, convenient storage of experimental data. (Only for GGST-3)

Technical Parameters:

Model	GGST-2	GGST-3
Test Range	5~1000 Bloom g	
Test Accuracy Range	±0.3%	
Resolution	1Bloom g	
Travel	1~60mm	
Travel Accuracy	≤±0.1mm	
Measured Diameter of Cylinder	12.700±0.010mm	
Consumption	60W	
Power Supply	AC110/220V±10%, 50/60Hz	
Standard Accessory	Constant Temperature Bath; Refrigerator	
Package Size (W*D*H)	360*360*530mm (Gel Strength Tester); 680*540*355mm (Constant Temperature Bath); 580*480*390mm (Refrigerator)	
Gross Weight	12kg (Gel Strength Tester); 25kg (Constant Temperature Bath); 21kg (Refrigerator)	

Laboratory Test Sieve

Application:

BK-TS200 lab test sieve is suitable for particles distribution analysis. It is primarily used to determine particle size distribution for particles, powder and liquid in laboratory and quality control department.



Screen sieve(optional)



Features:

- * Screen mesh size range: from 4 mesh to 500 mesh.
- * Timing range: 0~99min59s, time can be set from seconds to hours freely.
- * Typically requires 50~150g of sample material.

Technical Parameters:

Model	BK-TS200	BK-TS300
Working Layer	1~8 layers	
Screen Mesh Size	1-10, 10-250, 250-350, 350-400, 450, 500, 550, 600, 635	
Diameter	200mm	300mm
Material	Stainless steel 304	
Timing Range	0~99min59s	
Speed	1400r/min	
Power Consumption	125W	180W
Power Supply	AC110/220V±10%, 60/50Hz	
Standard Accessory	Lid and Base	
External Size(W*D*H)mm	400*330*370mm	
Package Size(W*D*H)mm	460*380*420mm	
Gross Weight	35kg	

Melting Point Apparatus Melting Point Tester

Melting point tester adopts capillary tube as sample tube and liquid temperature transfer mode prescribed in Pharmacopoeia. It is suitable for testing melting points of pharmaceutical, chemical reagents, spices, dye etc.

Features:

- * Equipped with thermo sensitive mini printer.
- * Automatic magnetic stirring system, oil bath temperature is uniform.
- * High-precision temperature sensor, can correct non-linear error automatically.
- * Automation: automatic measurement, automatic diagnosis and automatic alarm.
- * Full-automatic frequency converting control, has high temperature control precision and small linear error of heating rate.



MPTD-1

Technical Parameters:

Model	MPTD-1
Melting Point Test Range	RT ~ 270°C
Heating Rate	four levels: 0.5°C/min; 1°C/min; 1.5°C/min; 3.0°C/min
Deviation of Linear Heating Rate	<5%
Temperature Transfer Medium	Methyl silicone oil
Liquid Cup for Temperature Transfer	250ml beaker in tall form
Melting Point Test Precision	±0.5°C, Melting Point < 200°C ±1.0°C, Melting Point ≥ 200°C
Indicating Value Resolution	0.1 °C
Operational Environment Temperature	18°C~28°C
Interface	Standard serial printing interface, with micro-printer.
Power Supply	AC110/220V±10%, 50/60Hz
Dimensions(W*D*H)mm	200*320*305
Packing Size(W*D*H)mm	410*295*430
Gross Weight(kg)	7

Video Melting Point Apparatus



Features:

- * Android system with 10.1 inch touch screen, provides melting videos playback.
- * 720P HD camera for clear observation.
- * Use PID & PWM to control temperature.
- * The light source brightness and detection sensitivity can be adjusted to better measure dark color samples.
- * It can measure 4 samples at the same time.

Technical Parameters:

Model	BK-P685	BK-P682
Measurement Range	R.T.~400°C	R.T.~360°C
Measurement Mode	Automatic/visual (high-definition camera, video capture, playback monitoring)	
Measurement Methods	200	150
User name/password hierarchical management	200	150
Audit Trail	Optional (FDA)	
Electronic Signature	YES	
Minimum Digital Display	0.1°C	
Linear Heating-up Rate	0.1°C/min~20°C/min	
Accuracy	≤200°C±0.3°C; >200°C±0.5°C	
Repeatability	0.3°C (heating rate:1.0°C/min)	
Linear Heating Rate Error	±10%	
Number of Capillary	4	
Capillary Dimensions	Outer diameter: Φ1.4mm, Inner diameter:Φ1.0mm, Height:90mm	
Height of Sample	3mm	
Operation System	Android	
Date Storage	128G	64G
Display	10.1 inches capacitive touch screen	
Graph Storage	40000	20000
Interface	1*RS232, 3*USB, 1*RJ-45, WIFI	
Power Supply	100~240V, 50/60Hz, 150W	
Package Size	495*493*350mm	
Gross Weight	5kg	

Digital Melting Point Apparatus



BMP-1B

Features for BMP-1B:

- * Photoelectric test.
- * LCD display.
- * RS232 interface.
- * Real time melting curve.

Introduction:

The principle of the melting point apparatus is based on the phase transition process of matter, that is, the transition from a solid to a liquid state. When measuring with a melting point meter, first place the sample to be tested in the sample chamber and ensure that the sample is in a solid state. Then, heat is applied to the sample through a heating system, gradually increasing the temperature of the sample. At the same time, the observation system records and displays the temperature change curve of the sample. When the sample reaches its melting point, the solid material begins to melt into a liquid state. This process absorbs heat, causing a noticeable steep drop in the temperature curve. The melting point meter determines the melting point of a substance by monitoring this temperature change.

Technical Parameters:

Model	BMP-1B
Measuring Range	RT~320°C
Resolution	0.1°C
Linear heating-up Rate	0.2, 0.5, 1.0, 1.5, 2.0, 3.0, 4.0, 5.0°C/min
Temperature Accuracy	0.4°C (≤200°C), 0.7°C(>200°C)
Repeatability	0.3°C
Capillary Size	φ1.4mm(outside diameter), φ1.0mm(inside diameter), 90mm (height)
Sample Loading Height	3mm
Data Storage	/
Printer	RD TH-32C(Standard)
Power Supply	AC110/220V±10%, 50/60Hz
External Size(W*D*H)	360*290*270mm
Package Size(W*D*H)	580*430*310mm
Gross Weight	13kg

Digital Melting Point Apparatus

Features for BMP-2C/1C:

- * PID & PWM controller.
- * LCD touch screen for BMP-2C/BMP-1C.
- * USB & RS232 interface.
- * The melting curve can be recorded automatically.
- * It can calculate average value of initial and final melting points automatically.



BMP-2C/1C

Introduction:

The principle of the melting point apparatus is based on the phase transition process of matter, that is, the transition from a solid to a liquid state. When measuring with a melting point meter, first place the sample to be tested in the sample chamber and ensure that the sample is in a solid state. Then, heat is applied to the sample through a heating system, gradually increasing the temperature of the sample. At the same time, the observation system records and displays the temperature change curve of the sample. When the sample reaches its melting point, the solid material begins to melt into a liquid state. This process absorbs heat, causing a noticeable steep drop in the temperature curve. The melting point meter determines the melting point of a substance by monitoring this temperature change.

Technical Parameters:

Model	BMP-2C	BMP-1C
Measuring Range	RT~360°C	RT~400°C
Resolution	0.1°C	
Linear heating-up Rate	0.1°C~20°C/min	
Temperature Accuracy	0.4°C (≤200°C), 0.7°C (>200°C)	
Repeatability	0.3°C	
Capillary Size	φ1.4mm(outside diameter), φ1.0mm(inside diameter), 90mm (height)	
Sample Loading Height	3mm	
Data Storage	1000 sets	
Printer	RD TH-32C(Standard)	RD TH-32C(Optional)
Power Supply	AC110/220V±10%, 50/60Hz	
External Size(W*D*H)	360*290*270mm	
Package Size(W*D*H)	580*430*310mm	500*430*310mm
Gross Weight	13kg	11kg

Anaerobic Jar

Features:

- * Excellent airtight performance, avoiding any undue leakage
- * PMMA material, smooth surface, shock and impact resistant
- * Jar and lid are both transparent, sealing between lid and jar consists of an excellent quality O-ring
- * Strong jar-lid-clamp construction, guarantee the overall airtight performance
- * Colored stainless steel clamp with power electrostatic painting, durable and convenient for experimental management
- * Adopting quick snap-shut coupling, enabling quick connection to the system in one swift move
- * For BK-AJH Series, configuration list: anaerobic jar, 15/25R rack, pressure gauge(standard: oil type, optional: oil-free type); For BK-AJG Series, configuration list: anaerobic jar, 15/25Rrack.



BK-AJH Series

BK-AJG Series

Technical Parameters:

BK-AJH Series Pumping Type Jar: 3 to 5 minutes every time

Model	Contents	Petri Dish Holder	Packing Size(L*W*H)	Gross Weight
BK-AJH015	1stack of 6 dishes (φ9-10cm)	15R	245*215*295mm	2.3kg
	φ =130mm, h=150mm; 1.5liter			
BK-AJH025	1stack of 12 dishes (φ9-10cm)	25R	245*215*395mm	2.8kg
	φ =130mm, h=240mm; 2.5liter			
BK-AJH035	1stack of 18 dishes (φ9-10cm)	15/25R	245*215*495mm	3.3kg
	φ =130mm, h=330mm; 3.5liter			
BK-AJH050	3 stacks of 6 dishes (φ9-10cm)	3/25R	370*370*340mm	5.9kg
	φ =240mm, h=120mm; 5liter			
BK-AJH070	3 stacks of 8 dishes (φ9-10cm)	3/25R	370*370*370mm	6.3kg
	φ =240mm, h=160mm; 7liter			
BK-AJH100	3 stacks of 12 dishes (φ9-10cm)	3/25R	370*370*470mm	7.3kg
	φ =240mm, h=230mm; 10liter			

BK-AJG Series Hermetic Type Jar: About 4 hours every time

Model	Contents	Petri Dish Holder	Packing Size(L*W*H)	Gross Weight
BK-AJG015	1stack of 6 dishes (φ9-10cm)	15R	245*215*295mm	2.0kg
BK-AJG025	1stack of 12 dishes (φ9-10cm)	25R	245*215*395mm	2.5kg
BK-AJG035	1stack of 18dishes (φ9-10cm)	15/25R	245*215*495mm	3.0kg
BK-AJG050	3 stacks of 6 dishes (φ9-10cm)	3/15R	370*370*340mm	5.6kg
BK-AJG070	3 stacks of 8 dishes (φ9-10cm)	3/15R	370*370*370mm	6.0kg
BK-AJG100	3 stacks of 12 dishes (φ9-10cm)	3/25R	370*370*470mm	7.0kg

Bacterial Colony Counter

Application:

Widely used for bacilli inspection of food, drink, medicine, biological, make-up, health products, water for drink, domestic sewage, and industrial water.

Features:

- * CMOS integrated circuit and LED digital display.
- * The special probe counts sensitively and accurately.
- * It is composed by counter, probe and count pond, etc.
- * The magnification is variable by adjusting the flectional arm.



Technical Parameters:

Model	BC-50
Phonetic Counting	No
Amplification	5X, 10X
Counter Range	0~9999
Suitable Petri Dishes	Φ50-150mm
Character Height	13mm
Lamp Power	16W
Power Supply	AC220V, 50/60Hz
External Size(W*D*H)	270*200*70mm
Package Size(W*D*H)	370*270*330mm
Net Weight	1.7kg
Gross Weight	3kg

Biological Air Sampler

Application:

It is designed according to the principle of multi jet holes particle impact and isokinetic sampling. And it gets the consistence of animalcule more accurately. It is an ideal air biological sampler for medicine plant, hospital, biological products, food machining, public place, etc.



Features:

- * Sampling hole has many small holes to reduce particles superposition and reduce error of animalcule count.
- * Programmable, sampling quantity can be set from 0.01 to 9.0m³.
- * LCD screen displays sampling quantity, sampling time, etc.
- * Sampling time can be set automatically.
- * Up to 256 samples data storage of sampling time, sampling volume and other parameters.
- * Easy to change petri dish, just only take down sampling hole to change petri dish. (Diameter: Φ90*15mm)

Technical Parameters:

Model	PMS-01	BK-BAS-V
Sampling Volume	100L/min±5%	
Flow Velocity of	0.38m/s	0.38m/s
Sampling Holes	Basically the same as the clean room(Isokinetic sampling)	
Material	Anodised aluminium	SUS304 stainless steel
Structure	Microprocessor control, low noise pump sampling	
Rechargeable Battery	DC12V/3000mAh	DC14.8V/5000mAh
Operating Time on Battery	6~8h	
Power Supply	110V~220V, 50/60Hz	
External Size(W*D*H)	120*200*340mm	235*220*180mm
Package Size(W*D*H)	180*350*430mm	400*430*240mm
Net Weight	2kg	4.8kg
Gross Weight	5kg	8.5kg

Biological Air Sampler



Applications:

It is designed according to the principle of multi jet holes particle impact and isokinetic sampling. And it gets the consistency of animalcule more accurately. It is an ideal air biological sampler for medicine plant, hospital, biological products, food machining, public place, etc.

Features:

- * Sampling hole has many small holes to reduce particles superposition and reduce error of animalcule count.
- * LCD screen displays sampling quantity, sampling time, etc.
- * Sampling time can be set automatically.
- * Easy to change petri dish, just only take down sampling hole to change petri dish. (Diameter: $\phi 90 \times 15 \text{mm}$)
- * With USB interface, can output data easily.
- * Main R & D acquisition chip, sampling flow more stable

Technical Parameters:

Model	BK-BAS2
Sampling Volume	100L/min, $\pm 5\%$
Sampling Port	397 mesh, diameter $\phi 0.7 \text{mm}$ micropores
Sampling Quantity	1-9999L
Storage Data	5000pcs
Sampling Delay	0-255s (adjustable)
Operating Time on Battery	4h
Power Supply	100-240V, 50/60Hz
Packing Size	350*300*200mm
Gross Weight	6kg

Microbial Limit Tester

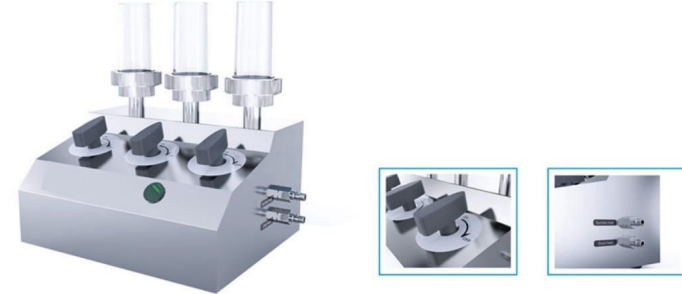

Introduction:

BXD-300 is a device for microbial detection or particle pollution based on the principle of membrane filtration. The microorganism (or particulate matter) in the sample solution is trapped by the filtration effect of the filter membrane. The filter membrane containing microorganisms (or particulate matter) is then transferred into the medium. After the medium was cultured in the incubator, the colonies were counted and identified. Applicable to pharmaceutical, food and beverage, cosmetics, chemical industry, environmental protection water quality monitoring, CDC and so on.

Application:

Widely used in pharmaceutical, cosmetics, water quality monitoring, chemical, CDC, food and beverage industries.

Features:

- * Built-in high-performance diaphragm pump, high flow, low noise.
- * Independent detachable filter head, can be matched with a variety of filter devices.
- * By supporting valve switch, can independently control the flow rate of each filter head.
- * The body adopts 304 mirror stainless steel, conducive to surface sterilization.
- * Detachable filter unit for moist heat sterilization at 121°C .

Technical Parameters:

Model	BXD-300
Filter Bottle	1000ml
Membrane Diameter	$\Phi 50 \text{mm}$
Filter Volume	100ml*3
Air Pump Flow	24L/min
Noise	65dB
Consumption	20W
Power Supply	220/110V, 50/60Hz
External Size	280*215*170mm
Package Size	535*265*290mm
Net Weight	5kg(without filter bottle)
Gross Weight	15kg

Carbon & Sulfur Analyzer



BK-CSA5

Introductions:

High-frequency Infrared Carbon & Sulfur Analyzer can determine the percentage of carbon and sulfur in steel, iron, alloy, nonferrous metal, cement, mineral, glass and other material.

Technical Parameters:

Working Principle	High-frequency inductive combustion and infrared absorption system
Sample Weight (Solid steel)	Standard 0.5g
Accuracy	C/S: 0.1ppm
Analysis Time	25-60s adjustable (normally: 35s)
Working Cycle	24 hours

The difference between BK-CSA5 and BK-CSA6:

Model	BK-CSA5	BK-CSA6
Appearance	Desktop detector, with desktop high-frequency furnace, save space	Separate work station, with vertical high-frequency furnace
Analysis Range	C: 0.0005%-6.0000% (can be extended to 99.999%) S: 0.0005%-0.5000% (can be extended to 99.999%)	C: 0.0001%-10.0000% (can be extended to 99.999%) S: 0.0001%-3.50000% (can be extended to 99.999%)
Analysis Pool	2 pools	2 pools (optional 4 pools)
Consumption	2.2KW	2.5KW
Power Supply	AC220V±10%, 50/60Hz	
Package Size(W*D*H)	1380*760*980mm	1670*750*960mm, 750*580*1430mm
Gross Weight	193kg	150kg, 180kg
Standard Accessories	Main unit, high frequency automatic inductive combustion furnace, electric balance 1000 times effective analysis of spare parts	

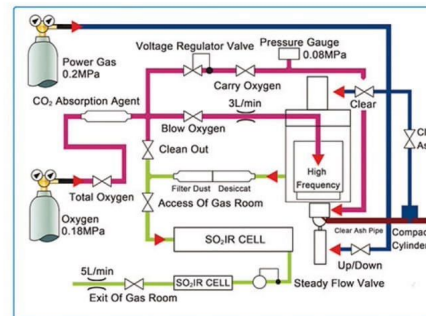

BK-CSA5/BK-CSA6 Gas Circuit Diagram

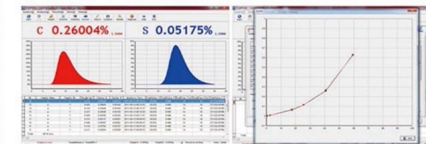

Analysis Software

Using Deliph software compiler, WINDOWS XP, Win7, Win8, Win10 system.

Using the drop-down menu and shortcut operation, with the functions of multi-user administrator, curve fitting, coefficient correction, treatment of results, printing, system diagnosis and others.

High Frequency Oscillating Circuit
Current / Voltage / Power / Choosing the way to regulate the furnace temperature, suitable to various materials of samples.



Control Circuit
Double CPU modular design, high of integration, stable and reliable.
24 bit high speed sampling chip, high sampling precision.

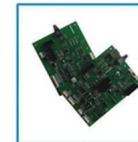

High Precision Pump

In response to the input pressure change, to ensure that the analysis of gas flow. Constant output, so as to ensure the stable and reliable analysis results.



Infrared Detecting Pool

Gold-plating carbon sulfur analysis pool and high precision of pyroelectric infrared detector. New platinum infrared light source, heating duration, spectral characteristics of high efficiency. Microstepping motor, good thermal stability.



BK-CSA6

COD Analyzer

Application:

* It is widely used in water quality monitoring in environmental protection, petroleum, chemical industries, health, etc.



COD-100

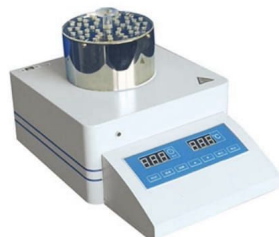

COD-100R

Features:

- * LCD display
- * Dichromate colorimetric method, LED light source, long service life
- * Two-point calibration (zero and full scale calibration)
- * Measurements can be displayed directly, needless to count
- * Support to connect with PC through USB interface
- * Data can be consulted, deleted and printed

Technical Parameters:

Model	COD-100	
Measuring Principle	Dichromate colorimetric method	
Range	COD	0.0~1500mg/L
	Electrolysis Current Divide	—
Accuracy	Basic Accuracy	±8%
	Repeatability	3%
Stability	COD data changing less than 6mg/L within 20mins	
Calibration	Two-point calibration(zero and full scalecalibration)	
Data Storage	200 data with time-and-date stamp	
Digester COD-100R	Digestion Method	Sealing reflux method(could dispelling 21 samples simultaneously)
	Digestion Temperature	100~165℃
	Digestion Time	0~120min
Power Supply	AC110/220V±10%, 50/60Hz	
Standard Accessory	COD-100R digester	
Package Size(W*D*H)	COD-100: 370*305*330mm, Digester: 575*435*285mm	
Gross Weight	5kg, 10kg	

Portable Turbidimeter

Features:

- * Cold light source, narrowband interference optical system.
- * Large LCD display.
- * Able to store standard 20 curve and 1000 measurements value for BK-T201.
- * Able to store 50 curve and 1000 measurements value BK-T202.
- * Anticorrosive ABS main body, waterproof IP65 design.
- * 16-bit single chip microcomputer system.
- * Data protection function of power failure.
- * Could charge lithium-ion battery.



Technical Parameters:

Model	BK-T201	BK-T202
Measuring Range(NTU)	0~400	0~1000
Basic Error(F.S)	≤± 2%	
Repeatability(F.S)	≤± 2%	
Minimum Resolution(NTU)	0.01	
Power Supply	AC110/220V±10%, 50/60HZ	
Package Size	410*240*330mm	
Gross Weight	2.5kg	

Benchtop Turbidimeter

Features:

- * Measured concentration value can be stored, printed, inquired and uploaded to the computer.
- * Measurement channels can be selected, up to 16 channels (optional, customizable), corresponding to different wavelengths.
- * Measurement method can choose straight line method or broken line method.
- * Various security measures, can set the boot input password.
- * Light intensity can be adjusted, divided into 16 levels, arbitrary Settings.
- * Bilingual system, can be switched between Chinese and English.
- * USB interface, can be connected to the computer.
- * With printing function: test records can be immediately printed or query records printed.



BK-LT6A/BK-LT6B

Technical Parameters:

Model	BK-LT6A	BK-LT6B
Measuring Range(NTU)	0~400	0~1000
Basic Error(F.S)	≤±2%	
Repeatability(F.S)	≤±2%	
Minimum Resolution(NTU)	0.01	
Consumption	30W	
Power Supply	AC85~240V, 50/60Hz	
Package Size(mm)	480*390*360	
Gross Weight(kg)	4.8kg	

Colorimeter



BCM-110



BCM-200

Features for BCM-110:

- * Built-in white plate parameters. No need to calibrate each time.
- * Double locating: illuminating locating and precise cross locating.
- * Switchable double measurement end face: large area stable end face and small area measurement for concave-convex end face.
- * New integrating sphere optical path design: eliminating the stray light of main optical path and auxiliary optical path.
- * Equipped with rechargeable-capacity Li-ion battery.
- * Configured CQCS3 software to realize more functions by connecting PC computer
- * Hand-head structure, small and convenient

Features for BCM-200:

- * Leading Humanity Design and Convenient Operation, Auto White and Black Calibration at Startup, Structure Design in line with Ergonomics
- * Stable Measurement Performance
- * Convenient and Fast Locating
- * PC Software -CQCS3 Software realize more function expansion.
 - a. The corresponding software serial number and password protection.
 - b. Be able to perform color difference analysis, color difference cumulative analysis, chromaticity index, color sample database management, simulating object color, etc.
- * Advanced Power Management Design
 - a. Using high capacity Li-ion battery in colorimeter. It can be repeatedly charged.
 - b. Measuring more than 3000 times on one charge.

Technical Parameters:

Model	BCM-110	BCM-200
Illuminating/Viewing Geometry	8/d	
Measuring Aperture	Φ4mm	Φ8mm
Detector	Silicon photoelectric diode	
Color Space	CIE L*a*b*C*h* CIE L*a*b*CIEXYZ	
Color Difference Formula	ΔE^*ab ΔL^*a^*b ΔE^*C^*h	
Light Source	D65	
Light Source Device	LED blue light excitation	
Display	TFT LCD	
Errors Between Each Equipment	$\leq 0.80\Delta E^*ab$	$\leq 0.50\Delta E^*ab$
Storage	100pcs standards, 20000pcs samples	100pcs standards, 20000pcs samples
Repeatability	Standard deviation within ΔE^*ab 0.08 Average of 30 measurements of standard white plate	
Lamp Life	3 years, more than 1 million time	5 years, more than 1.6 million time
Charging Time	8 hours-100% electricity	2 hours(8 hours for first charge)-100% electricity
Measurement Times Before Recharging	3000 times in 8 hours	
Ambient Temp./Humidity Range	-10~40°C, relative humidity 0~85% without condensation	
Data Interface	USB	
Optional Accessory	Miniature thermal printer, Powder test box	Universal Test Components, Powder test box, Miniature thermal printer
Power Supply	Rechargeable li-ion battery 3.7V@3200mAh	
External Size(W*D*H)	205*67*80mm	205*70*100mm
Package Size(W*D*H)	370*170*310mm	
Net Weight	0.5kg	0.45kg
Gross Weight	3kg	

Spectrophotometric Colorimeter

Application:

Spectrophotometric colorimeter is widely used in plastic, electronic, painting, coating, ink, textile, garment, printing and dyeing, food, medical, cosmetic, industries, scientific research institutes, schools and laboratories. It can measure reflectance spectrum and other color index precisely. BCM-810 spectrophotometer not only can help to perform color matching and color management studies, but also can control product quality management accurately. The instrument is equipped with high-end color management software which can connect PC to achieve more extension functions.



Technical Parameters:

Model	BCM-810
Illumination/Observation System	d/8(diffused illumination, 8-degree viewing angle) Conforms to CIE No.15, GB/T 3978
Integrating Sphere Size	Φ58mm
Light Source	Combined LED sources
Sensor	Silicon photodiode array
Wavelength Range	400~700nm
Wavelength Pitch	10nm
Reflectance Range	0~200%
Measuring Aperture	Φ8mm
Color Space	CIE LAB, XYZ, Yxy, LCh, CIE LUV, LAB&WI&YI
Color Difference Formula	ΔE^*ab , ΔE^*uv , ΔE^*94 , $\Delta E^*cmc(2:1)$, $\Delta E^*cmc(1:1)$, $\Delta E^*cmc(l:c)$, CIE2000 ΔE^*00 , $\Delta E(h)$
Other Chromaticity Data	WI(ASTM E313, CIE/ISO, AATCC, Hunter), YI(ASTM D1925, ASTM 313), Metamerism index (Mt), Color strength color stain, Color fastness
Data	Metamerism Index (Mt), Color Strength Color Stain, Color Fastness
Observer	2°/10°
Illuminant	D65, D50, A, C, D55, D75, F1, F2, F3, F4, F5, F6, F7, F8, F9, F10, F11, F12

Model	BCM-810
Display Data	Spectral value/Graph, Colorimetric value, Color difference value/Graph, Pass/Fail result, Color offset, Color simulation, Color index setting(ΔE^*94 , ΔE^*cmc , $\Delta E2000$), Tolerance prompt, Reverse prompt, Time setting, Language setting, Restore factory setting
Measurement Time	1.5s
Repeatability	Spectral reflectance: Standard deviation within 0.1%(400~700nm: within 0.2%) Colorimetric value: Standard deviation within ΔE^*ab 0.04 (Measurement conditions: White calibration plate measured 30 times at 5 seconds intervals after white calibration was performed.)
Inter Instrument Agreement	Within ΔE^*ab 0.2 (Average for 12 BCRA Series II color tiles)
Battery	Li-ion battery. 2800 times within 8 hours.
Lamp Life	5 years, more than 1.6 million measurements
Display	3.5 inch TFT LCD, Capacitive touch screen
Interface	USB/RS-232
Data Memory	1000 Standards, 15000 Samples
Ambient Temp.	0~40°C (32~104°F)
Storage Temp.	-20~50°C (-4~122°F)
Standard Accessory	Power adapter, Li-ion battery, Operating instruction, CD-ROM (Containing management software), Data line, White and black calibration cavity, Protective cover and wrist strap
Optional Accessory	Universal test components, Micro printer, Powder test box
External Size(W*D*H)	90*77*230mm
Package Size(W*D*H)	370*170*310mm
Net Weight	600g
Gross Weight	3kg
Notes	The specifications are subject to change without notice

Benchtop Grating Spectrophotometer



Introduction:

BK-GS6060 is a benchtop grating spectrophotometer, which has many features, like 7 inches TFT capacitive touch screen display, full illuminants, reflective d/8 and transmissive d/0 geometry (including or excluding UV). With very stable and precise color measurement, large storage and powerful PC software all makes BK-GS6060 ideal for color analysis within R&D and laboratory environments.

Features:

- * High configuration of hardware: 7 inches TFT Color Capacitive Touch screen Display; Concave Grating.
- * Double Array 256 Image Element CMOS Sensor; Long life-span stable LED, UV LED and xenon lamp.
- * With reflective and transmissive spectrum, accurate Lab value, good to calculate color formula and do precise color transmission.
- * Auto identify measuring aperture. Freely switchable between 4 measuring apertures: ϕ 25.4mm/15mm/8mm/4mm. Users also can customize apertures.
- * Built-in temperature sensor to monitor and compensate the measuring temperature to ensure the measurement more precision.
- * Wavelength range 360nm ~780nm. Built-in 400nm cut off/420nm cut off/460nm cut off (only xenon lamp edition), more professional in UV measurement.
- * Independent light source detector, continuously monitor the condition of light sources to ensure the light source reliable.
- * Multiple measurement modes: Quality Management Mode, Sample Mode; Meet more users' requirement.
- * Multiple accessories, sample holders, fixation clamp, suitable to more working condition.
- * Big capacity data storage, for 20000 pieces test result.
- * Built-in camera locating.
- * More powerful extended functions at the PC software.

Application:

BK-GS6060 benchtop spectrophotometer is used to do precise color analysis and transmission in laboratories. It can be widely applied in different industries, such as plastics, electronics, paint and ink, printing, garments, leather, paper, auto, medical, cosmetics, food, science institutes, laboratories.

Technical Parameters:

Model	BK-GS6060
Optical Geometry	Reflect: di: 8°, de: 8°(diffused illumination, 8-degree viewing angle); SCI (specular component included) / SCE (specular component excluded); Include UV / excluded UV light source Transmittance: di: 0°, de: 0° (diffuse illumination: 0° viewing); SCI (specular component included) / SCE (specular component excluded); Include UV / excluded UV light source; Haze(ASTM D1003), Conforms to CIE No.15, GB/T 3978, GB 2893, GB/T 18833, ISO7724/1, ASTM E1164, DIN5033 Teil7
Application	It is used for accurate analysis and transmission of laboratory color. Apply in paints, inks, textiles, garments, printing and dyeing, printing etc industries for color transfer and quality control.
Integrating Sphere Size	Φ 154mm
Light Source	360 nm to 780 nm, Combined LED Light, 400nm cut-off light source,420nm Cut-off light source, UV Lamp
Spectrophotometric Mode	Concave Grating
Sensor	256 Image Element Double Array CMOS Image Sensor
Wavelength Range	360-780nm
Wavelength Interval	10nm
Semi-band Width	10nm
Measured Reflectance Range	0-200%
Measuring Aperture	Reflective: Φ 30mm/ Φ 25.4mm, Φ 18mm/ Φ 15mm, Φ 10mm/ Φ 8mm, Φ 6mm/ Φ 4mm; Transmissive: Φ 30mm/ Φ 25.4mm
Specular Component	Reflectance: SCI&SCE / Transmittance: SCI&SCE
Color Space	CIE LAB, Xy, Yxy, LCh, CIE LUV, Musell, s-RGB, HunterLab, β xy, DIN
Color Difference Formula	$\Delta E^* ab$, $\Delta E^* uv$, $\Delta E^* 94$, $\Delta E^* cmc(2:1)$, $\Delta E^* cmc(1:1)$, $\Delta E^* 00$, $DIN\Delta E 99$, ΔE (Hunter)
Other Colorimetric Index	WI (ASTM E313, CIE/ISO, AATCC, Hunter, YI (ASTM D1925, ASTM 313), TI (ASTM E313, CIE/ISO), MI (Metamerism Index), Staining Fastness, Color Fastness, Color Strength, Opacity, Gardner Index, Pt-Co Index, 555 Index
Observer Angle	2°/10°
Illuminant	D65, A, C, D50, D55, D75, F1, F2, F3, F4, F5, F6, F7, F8, F9, F10, F11, F12
Displayed Data	Spectrogram/Values, Samples Chromaticity Values, Color Difference Values/Graph, PASS/FAIL Result, Color Offset
Measuring Time	About 2.4s (Measure SCI & SCE about 5s)
Repeatability	Spectral reflectance: Φ 25.4mm/SCI, Standard deviation within 0.04% (400 nm to 700 nm: within 0.04%) Chromaticity value: Φ 25.4mm/SCI, Standard deviation within $\Delta E^* ab$ 0.01 (When a white calibration plate is measured 30 times at 5 second intervals after white calibration) Chromaticity value: Φ 25.4mm/SCI, Standard deviation within $\Delta E^* ab$ 0.02 (When a white calibration plate is measured 30 times at 5 second intervals after white calibration)
Inter-instrument Error	Φ 25.4mm/SCI, Within $\Delta E^* ab$ 0.12 (Average for 12 BCRA Series II color tiles)
Illuminant Life Span	5 years, more than 3 million times measurements
Display	7-inch TFT color LCD, Capacitive Touch Screen
Data Port	USB & Bluetooth
Data Storage	Standard 5000 Pcs, Sample 40000 Pcs (One PCS can include both SCI and SCE)
Language	Chinese, English
Operating Environment	0~40°C, 0~85%RH (no condensing), Altitude < 2000m
Storage Environment	-20~50°C, 0~85%RH (no condensing)
Standard Accessory	White and Black Calibration Board, Checking Green Board, Sample Holder, f 4mm, f 8mm, f 15mm, f 25.4mm Aperture, Power Adapter, USB Cable, User Guide, PC Software
Optional Accessory	Micro printer, Transmissive Test Clamp Component
Power Supply	DC 24V, 3A; Power adapter: 110~230V 50/60HZ
External Size (L*W*H)	370*300*200mm
Weight	9.6kg
Package Size (W* D*H)	350*470*520mm
Gross Weight	18kg

Whiteness Meter



Introduction:

Whiteness meter with the digital display is mainly applicable for the measurement of the whiteness degree on the surface of the object or the powder in the white color and the color close to white. The whiteness degree can be accurately educed that is consistent with the visual degree. The opacity degree of the paper can also be accurately measured. This instrument can be widely applied for the measurement of the whiteness degree of the objects like textile & printing & dying, oil paint & dope, chemical construction material, paper & paper plate, plastic product, white cement, ceramics, porcelain enamel, porcelain clay, french chalk, starch, flour, salt, wash, and cosmetics, etc.

Features for BK-WM1:

- * AC & DC power supply, low power consumption, cabinet and handsome contour design, facilitating field and lab use.
- * Configured with auto power-off function and low power dissipation circuit, able to effectively prolong service life of battery; free of ill influence from sunlight.
- * The simple operation, and can accurately measure the opacity degree of the paper.
- * Adopt the standard white plate rated by the central government to convey the standard value, and the measurement is accurate and reliable.
- * Configured with output port of measured values, possible to connect with recording meter.

Features for BK-WM2:

- * The design with the reliable active platform, can effectively prevent the phenomenon of the light leak in the measurement hole.
- * The simple operation, and can accurately measure the opacity degree of the paper.
- * Adopt the standard white plate rated by the central government to convey the standard value, and the measurement is accurate and reliable.

Features for BK-WM2A:

- * The configuration with the high-automatic & multi-function microcomputer, equipped with the RS232 serial communication interface to connect the printer.
- * The outstanding color-measurement performance is very accurate. Adopt the CAD, and the overall spectrum characteristics of the instrument comply with the responding curve of the CIE standard observer, and can accurately obtain the ISO whiteness degree.
- * The embedded clock memory & storage system can store the measurement & correction data in real time, and can store and transfer 20 groups of the measurement data for long time, and can be used for the historic reference.
- * The quick automatic correction, with the prompt of the self-diagnosis information, rapid and stable response, reliable maintenance-free operation.

Features for BK-WM3A:

- * Adopt the quality imported & original components, with the high-efficiency & low-spoilage circuit, and with the good reliability.
- * The configuration with the high-automatic & multi-function microcomputer, equipped with the RS232 serial communication interface to connect the printer.
- * The outstanding color-measurement performance is very accurate. Adopt the CAD, and the overall spectrum characteristics of the instrument comply with the responding curve of the CIE standard observer, and can accurately obtain the ISO whiteness degree.
- * The embedded clock memory & storage system can store the measurement & correction data in real time, and can store and transfer 20 groups of the measurement data for long time, and can be used for the historic reference.
- * The quick automatic correction, with the prompt of the self-diagnosis information, rapid and stable response, reliable maintenance-free operation.

Technical Parameters:

Model	BK-WM1	BK-WM2	BK-WM2A	BK-WM3	BK-WM3A
Measuring Range	0~199		0~120		
Measuring Condition	45/0			0/d	D/0
Illuminant	D65				
Display	LCD				
Whiteness Mean	Whiteness degree of blue light Wb = R457				
Minimum Readout	0.1		0.01		
Calibrate	Φ15	Φ30			
Zero Draft	≤±0.1				
Basic Error	≤±2		≤±1		
Repeatability	0.2				
Power Supply	DC 1.5V, 5A alkaline dry cells, AC 220V/50Hz, DC7.5V 0.2A power supply adapter		AC220V, 50Hz(Optional 110V/50Hz, internal transformer)		
External Size	325*75*65mm	325*265*280mm		310*280*280mm	
Package Size	370*285*175mm		400*330*345mm		370*355*380mm
Gross Weight	1.8 kg	5 kg	5.65 kg	4.1 kg	

Morgue Freezer



BK-XG1



BK-XG2



BK-XG3



BK-XG4



BK-XG6

Features:

- * Anti-vibration and anti-overtum compressor.
- * Intelligent control system.
- * All stainless steel.
- * Polyurethane overall high pressure and high temperature foaming.
- * The refrigeration system of each chamber can be controlled individually.
- * Corpse tray can move freely with small roller wheels.

Technical Parameters:

Model	BK-XG1	BK-XG2	BK-XG3	BK-XG4	BK-XG6
Interior Size	2060*600*420mm, 1pc	2060*640*440mm, 2pcs	2060*640*440mm, 3pcs	2050*640*440mm, 4pcs	2050*640*440mm, 6pcs
Lowest Temp.	-30℃				
Accuracy	0.1℃				
Slide	Enlarged 100mm thickness load-bearing frame				
Stretcher	Made of all stainless steel (strong corrosion resistance)				
Evaporator	Direct-cooled evaporator with built-in copper coil, no solder joints inside				
Condenser	Air-cooled condenser, silent cooling fan				
Insulation	Polyurethane overall high-pressure and high temperature foaming (thickness about 100mm)				
Power Supply	Standard: 220V, 50/60Hz; Optional: 110V, 60Hz				
Power	850W	850W	1300W	1300W	1500W
Packing Size	2700*800*700mm	2300*950*1700mm	2300*960*2200mm	2300*1800*1700mm	2300*2100*1700mm
Gross Weight	200kg	400kg	500kg	700kg	840kg

Mouse Cage



Material: PC



Material: PP



Features:

- * Separate the feces and urine, easy to operate.
- * Standard accessories: lids, bottles and stoppers
- * Water bottle rack with a stainless steel tube below, to avoid the mouse when the water leakage to the ground.

Technical Parameters:

Model	Material	Size
BK-CP3	PP/PC	318*202*136mm
BK-CP5	PP/PC	300*200*130mm
BK-SS4	PP	485*350*200mm
BK-R1	PP	465*300*180mm
BK-R5	PP/PC	465*300*150mm
BK-H1	PP	545*395*200mm
BK-CP4	PP/PC	375*330*190mm
BK-JM1	PP	466*314*200mm
BK-JM2	PP	320*220*160mm
BK-JM2	PP	375*270*160mm

IVC Mouse Cage System

Main Machine



Features:

- * IVC mouse cage system is composed of three parts: cage box, cage frame and main machine.
- * PLC or MCU control, inlet and exhaust fans are well-known domestic brands, stable and reliable operation.
- * With high-precision wind speed pressure difference sensor, temperature and humidity sensor.
- * Built-in UPS, the fan continues working when the external power supply interrupted.
- * With filter timing function to remind users to update the filter.
- * With abnormal parameters alarm, filter life alarm, power failure alarm.
- * Supporting remote monitoring through computer or mobile phone(PLC).

Main Machine Technical Parameters:

Ventilation Rate	10~85 times/h
Airflow Velocity	≤0.1m/s
Air Cleanliness	ISO Level 5
Noise	≤55dB
Colony Number	0
Pressure Difference	≥10pa
Power Supply	110~220V, 50/60Hz
External Size	470*605*1550mm
Package Size	570*705*1700mm
Gross Weight	105kg

Cage Frame



- * Cage frame material is SUS304 stainless steel.
- * The gas pipe and the cage box are connected by a silicone gas nozzle. The inlet and exhaust vents of the cage box and cage frame adopt non-invasive structure.
- * Inlet and exhaust duct can be disassembled for easy cleaning and disinfection.
- * 4 inch PU wear-resistant universal wheel, no scratching PVC floor, flexible movement without noise. The arc angle structure prevents the damage of the during handling.
- * The vertical and horizontal positions of the cage frame are numbered with letters such as A, B, C and numbers such as 1, 2, 3, which is convenient for experiment management.
- * The cage guide rail is made of ABS engineering plastic, and with instructions for cage installation in place (if not in place, there are light instructions to remind the operator).

Cage Box



- * The cage box is composed of plastic base box, box cover, stainless steel mesh cover, drinking bottle and record card. The box cover has exhaust valve, silicone sealing circle and hasp.
- * Base box and cover are molded by PPSU or PSU plastic. PPSU thermal deformation temperature>180°C, steam sterilization for more than 500 times without deformation on condition that 205 kPa, 134°C, 5min. Thermal deformation temperature of PSU material> 150°C, steam sterilization over 200 times without deformation on condition that 205 kPa, 134°C, 5min.
- * The cage box and 500ml drinking bottle are autoclavable.
- * The box cover exhaust outlet is provided with a metal filter (25*50mm) to prevent the dust in the cage from being inhaled the cage frame and blocking the pipeline.
- * The ventilated window is directly connected to the outside world, covered with 0.2μm high efficiency filter membrane, which can be directly washed and autoclavable.
- * After the cage box is removed from the cage frame, the air inlet and exhaust valves of the cage box will automatically close immediately.

Rat IVC Cage System

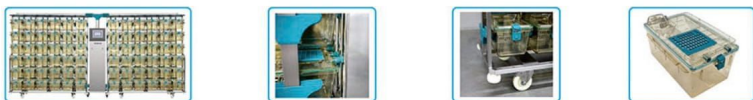

Introduction:

The rat IVC cage system is composed of intelligent main machine, cage frame, cage box and other parts. It is suitable for feeding and experiment of clean grade or SPF grade less harmful infected rats, especially suitable for raising immunodeficient and transgenic animals, to effectively ensure the safety of operators, animals and the environment.

Technical Parameters:

Model	Cage Number	Cage Frame Size (L*W*H)	Cage Box Size (L*W*H)	Cage Internal Height	Cage Frame & Cage Box Package Size(mm)	Cage Frame & Cage Box Gross Weight
BK-SL500-24 (4*6)	24	1186*540*1945mm	500*274*226mm	≤180mm	1286*640*2095mm	60kg
BK-SL500-30 (5*6)	30	1475*540*1945mm	500*274*226mm	≤180mm	1575*640*2095mm	71kg
BK-SL500-36 (6*6)	36	1764*540*1945mm	500*274*226mm	≤180mm	1864*640*2095mm	82kg

Guinea-pig IVC Cage System



Technical Parameters:

Model	Cage Number	Cage Frame Size (L*W*H)	Cage Box Size (L*W*H)	Cage Frame & Cage Box Package Size(mm)	Cage Frame & Cage Box Gross Weight
BK-SL520-16 (4*4)	16	1638*580*1476mm	520*385*415mm	1738*680*1626mm	72kg
BK-SL520-20 (4*5)	20	1638*580*1781mm	520*385*415mm	1738*680*1931mm	84kg

Mouse IVC Cage System(Intensive Type)



Technical Parameters:

Model	Cage Number	Cage Frame Size (L*W*H)	Cage Box Size (L*W*H)	Cage Frame & Cage Box Package Size(mm)	Cage Frame & Cage Box Gross Weight
BK-SL380-60 (6*10)	60	1346*500*1990mm	380*204*162mm	1446*600*2140mm	90kg
BK-SL380-70 (7*10)	70	1562*500*1990mm	380*204*162mm	1662*600*2140mm	100kg
BK-SL380-80 (8*10)	80	1778*500*1990mm	380*204*162mm	1878*600*2140mm	106kg
BK-SL380-90 (9*10)	90	1994*500*1990mm	380*204*162mm	2094*600*2140mm	114kg
BK-SL380-120 (6*10)-SM	120	1346*710*1990mm	380*204*162mm	1446*810*2140mm	100kg
BK-SL380-140 (7*10)-SM	140	1562*710*1990mm	380*204*162mm	1662*810*2140mm	120kg
BK-SL380-160 (8*10)-SM	160	1778*710*1990mm	380*204*162mm	1878*810*2140mm	130kg
BK-SL380-180 (9*10)-SM	180	1994*710*1990mm	380*204*162mm	2094*810*2140mm	140kg

Mouse IVC Cage System



Introduction:

It is composed of intelligent main machine, cage frame, cage box and so on. It is suitable for feeding and experiment of clean grade or SPF grade less harmful infected mice, to effectively ensure the safety of operators, animals and the environment.

Technical Parameters:

Model	Cage Number	Cage Frame Size (L*W*H)	Cage Box Size (L*W*H)	Cage Frame & Cage Box Package Size(mm)	Cage Frame & Cage Box Gross Weight
BK-SL385-32 (4*8)	32	890*500*1960mm	385*194*172mm	990*600*2110mm	68kg
BK-SL385-36 (4*9)	36	890*500*2020mm	385*194*172mm	990*600*2170mm	73kg
BK-SL385-40 (5*8)	40	1100*500*1960mm	385*194*172mm	1200*600*2110mm	77kg
BK-SL385-45 (5*9)	45	1100*500*2020mm	385*194*172mm	1200*600*2170mm	82kg
BK-SL385-48 (6*8)	48	1310*500*1960mm	385*194*172mm	1410*600*2110mm	85kg
BK-SL385-54 (6*9)	54	1310*500*2020mm	385*194*172mm	1410*600*2170mm	90kg
BK-SL385-56 (7*8)	56	1520*500*1960mm	385*194*172mm	1620*600*2110mm	90kg
BK-SL385-63 (7*9)	63	1520*500*2020mm	385*194*172mm	1620*600*2170mm	95kg
BK-SL385-64 (8*8)	64	1730*500*1960mm	385*194*172mm	1830*600*2110mm	100kg
BK-SL385-72 (8*9)	72	1730*500*2020mm	385*194*172mm	1830*600*2170mm	105kg
BK-SL385-72 (9*8)	72	1940*500*1960mm	385*194*172mm	2040*600*2110mm	105kg
BK-SL385-81 (9*9)	81	1940*500*2020mm	385*194*172mm	2040*600*2170mm	110kg
BK-SL385-96 (6*8)-SM	96	1310*710*1960mm	385*194*172mm	1410*810*2110mm	105kg
BK-SL385-108 (6*9)-SM	108	1310*710*2020mm	385*194*172mm	1410*810*2170mm	115kg
BK-SL385-112 (7*8)-SM	112	1520*710*1960mm	385*194*172mm	1620*810*2110mm	115kg
BK-SL385-126 (7*9)-SM	126	1520*710*2020mm	385*194*172mm	1620*810*2170mm	125kg
BK-SL385-128 (8*8)-SM	128	1730*710*1960mm	385*194*172mm	1830*810*2110mm	126kg
BK-SL385-144 (8*9)-SM	144	1730*710*2020mm	385*194*172mm	1830*810*2170mm	136kg
BK-SL385-144 (9*8)-SM	144	1940*710*1960mm	385*194*172mm	2040*810*2110mm	146kg

Rabbit IVC Cage System



Technical Parameters:

Model	Cage Number	Cage Frame Size (L*W*H)	Cage Box Size (L*W*H)	Cage Frame & Cage Box Package Size(mm)	Cage Frame & Cage Box Gross Weight
BK-TL520-12 (3*4)	12	1236*580*2026mm	520*389*270mm	1336*680*2176mm	63kg
BK-TL520-16 (4*4)	16	1638*580*2026mm	520*389*270mm	1738*680*2176mm	80kg

Dehumidifier

Home Dehumidifier



BKDH-820E/830E

Features:

- * With active carbon filter. * Timing range: 1~24 hours.
- * LED display, indicate humidity. * Microcomputer control, intelligent operation.
- * With drains to keep continuous drainage function.
- * Low temperature available, efficient automatic defrosting system.
- * E series, high sensitivity causative touch screen, D series, button screen.
- * Voice prompt function: the dehumidifier stop work and alarm when the water tank is full.

Technical Parameters:

Model	BKDH-820E	BKDH-830E
Humidity Removal Capacity	20L/24H	30L/24H
Humidity Adjusted Range	40%~90%RH	
Air Circulation	280 m³/h	310 m³/h
Refrigerant	R134A	
Material	ABS	
Applying Area	30~70 m²	35~80 m²
Power Supply	Standard: 220V 50Hz, Optional: 110V 60Hz	
Consumption	280W	330W
Water Tank	5.1L	
External Size (W*D*H)	373*266*612mm	
Packing Size (W*D*H)	410*310*680mm	
Net Weight	14kg	14.5kg
Gross Weight	15kg	15.5kg
Border Color	Green/Black	Green/Black



BKDH-850D/860D

BKDH-860E

Features:

- * With active carbon filter. * Timing range: 1~24 hours.
- * LED display, indicate humidity. * Microcomputer control, intelligent operation.
- * With drains to keep continuous drainage function.
- * Low temperature available, efficient automatic defrosting system.
- * E series, high sensitivity causative touch screen, D series, button screen.
- * Voice prompt function: the dehumidifier stop work and alarm when the water tank is full.

Technical Parameters:

Model	BKDH-850D	BKDH-860D	BKDH-860E
Humidity Removal Capacity	50L/24H	60L/24H	
Humidity Adjusted Range	40%~90%RH		
Air Circulation	710 m³/h	723 m³/h	
Refrigerant	R410A		
Material	ABS		
Applying Area	50~110 m²	70~120 m²	
Power Supply	Standard: 220V 50Hz, Optional: 110V 60Hz		
Consumption	700W	740W	
Water Tank	10L		
External Size (W*D*H)	436*290*720mm		
Packing Size (W*D*H)	490*350*780mm		
Net Weight	23.5kg	24.5kg	
Gross Weight	26kg		
Border Color	Black		Black/Green

Commercial Dehumidifier



Features:

- * Microcomputer control, intelligent operation
- * LED display, indicate humidity
- * Low temperature available, efficient automatic defrosting system
- * Timing range: 1~24 hours
- * Pipe continue drainage function

Technical Parameters:

Model	BKDH-890D	BKDH-8138D
Humidity Removal Capacity	90L/24H	138L/24H
Humidity Adjusted Range	10%~90%RH	
Air Circulation	1100 m ³ /h	1200 m ³ /h
Refrigerant	R410A	
Material	Cold Rolled Plate Coating	
Applying Area	90~150 m ²	130~180 m ²
Power Supply	Standard: 220V 50Hz, Optional: 110V 60Hz	
Consumption	1300W	1500W
External Size (W*D*H)	480*420*960mm	480*420*1060mm
Packing Size (W*D*H)	550*470*1060mm	550*470*1150mm
Net Weight	50kg	60kg
Gross Weight	55kg	65kg

Industrial Dehumidifier



Features:

- * With memory function in case of power-failure
- * World famous brand compressor, and high-quality centrifugal fan with low noise
- * Microcomputer automatic control, large LED display
- * 10L built-in water tank or external pipe is available (for BKDH-6.8DT)
- * Equipped with a handle and big wheels, mobile and portable (for BKDH-6.8DT)
- * Timing range: 1~24 hours
- * Automatic defrost system with high-efficiency
- * Automatic fault diagnosis function
- * Continuous pipe drainage function

Technical Parameters:

Model	BKDH-6.8DT	BKDH-12KT	BKDH-15KT	BKDH-20KT
Humidity Removal Capacity	7L/h	10L/h	16L/h	20L/h
Working Condition	At 30°C, 80% humidity, it achieves maximum dehumidifying capacity			
Air Circulation	2000m ³ /h	2800m ³ /h	4000m ³ /h	5600m ³ /h
Refrigerant	R410A			
Control Precision	±5%RH			
Applying Area	180~230 m ²	250~350 m ²	350~400 m ²	450~550 m ²
Applicable Temperature	5~38°C			
Defrost	Auto Defrost			
Consumption	2100W	3800W	6100W	8000W
Drainage Type	10L Water tank(standard) or external pipe	External pipe		
Power Supply	Standard: 220V 50Hz, Optional: 220V 60Hz	Standard: 380V, 50Hz	Optional: 380V 60Hz, 480V 50/60Hz	
External Size(W*D*H)	525*740*1155mm	770*470*1630mm	1095*485*1750mm	1095*485*1750mm
Package Size(W*D*H)	770*590*1260mm	870*570*1640mm	1105*495*1760mm	1280*620*1900mm
Net Weight	95kg	140kg	250kg	270kg
Gross Weight	100kg	150kg	260kg	280kg

Densimeter

Solid Densimeter



Application:

Any type of solid, such as rubber, plastic, cables, hard alloy, glass, metal, powder, ceramics, fireproofing materials, magnetic materials, mineral and rock, cement, jewelry, etc.

Features:

- * Automatic zero tracking, buzzer warning, and overload warning.
- * Function of solution compensation: necessary if liquid other than water is used as a medium for measuring.
- * RS-232C included.

Technical Parameters:

Model	BK-DME300S	BK-DME600S
Capacity	0.005~300g	0.005~600g
Density Resolution	0.001g/cm ³	
Density Range	0.001~99.999g/cm ³	
Measuring Time	About 5s	
Measuring Principle	Archimedes principle	
Specific Gravity Measuring Frame	Unibody injection forming professional specific gravity measurement frame Size: 176*105*111 *mm (L*W*H)	
Measuring Tank	Unibody injection forming transparent measuring tank Size: 169*98*83 *mm (L*W*H)	
Standard Accessories	Tank, testing board, tweezer, thermometer, 100G weight, windshield, a set of particle measuring assembly, a set of floating body measuring assembly, power transformer.	
Optional Accessories	DE-40 printer	
Power Supply	AC110/220V±10%, 50/60Hz	
Package Size(W*D*H)mm	450*200*360	
Gross Weight(kg)	6.5	

Liquid Densimeter



Application:

Any type of liquid.
Measurement of special liquid such as volatile liquid, corrosive liquid, strong acid and strong alkali liquid need optional accessory DE-20B anti corrosive liquid measuring assembly.

Features:

- * LCD Display.
- * Samples under the temperature from normal to 100°C can be measured.
- * RS-232C included.

Technical Parameters:

Model	BK-DME300L
Capacity	0.005~300g
Density Resolution	0.001g/cm ³
Density Range	0.001~99.999g/cm ³
Measuring Time	About 5s
Measuring Principle	Archimedes principle displacement method
Weight Value Data Storage	1 group
Specific Gravity Measuring Frame	Stainless steel specific gravity measuring frame
Calibration Mode	Auto correction, auto detection.
Result Testing Method	Distilled water testing
Standard Accessories	Measuring plate, tweezer, thermometer, 100G weight, windshield, measuring frame, power transformer, DE-20A standard liquid measuring assembly (Components of DE-20A standard liquid measuring assembly: Two stainless steel pothooks, one normal glass weight, one normal stainless steel weight, two beakers)
Optional Accessories	DE-40 printer, DE-20B anti corrosive liquid measuring assembly,
Power Supply	AC110/220V±10%, 50/60Hz
Package Size(W*D*H)mm	450*200*360
Gross Weight(kg)	6.5

Solid and Liquid Densimeter



Application:

It is suitable for the field of quality management, cost control, new formula researching and material studying, etc. Any form of solid could be measured. Measurement of special liquid such as volatile liquid, corrosivity liquid, strong acid and strong alkali liquid need optional accessory DE-20B anti corrosive liquid measuring assembly.

Features:

- * Automatic zero tracking, buzzer warning, and overload warning.
- * Function of solution compensation: necessary if liquid other than water is used as a medium for measuring.
- * Actual water temperature compensation.
- * RS-232C included.

Technical Parameters:

Model	BK-DME300D	BK-DME600D	
Capacity	0.005~300g	0.005~600g	
Density Resolution	0.001g/cm ³		
Density Range	0.001~99.999g/cm ³		
Measuring Time	About 5s		
Solid Mode	Measuring Principle	Archimedes principle general solid test method	
	Specific Gravity	Unibody injection forming professional specific gravity measurement frame	
	Measuring Frame	Size: 176*105*111mm (L*W*H)	
	Measuring Tank	Unibody injection forming transparent professional measuring tank Size: 169*98*83mm (L*W*H)	
Mixed Material Percentage	Function introduction	Automatically read the percentage of the main material in composite which consist of two materials	
	Setting	Freely set the density value of main material and subordinate material	
	Display	Density value, percentage of main material	
Liquid Mode	Measuring Principle	Archimedes principle displacement method	
	Weight Value Data Storage	1 group	
	Specific Gravity	Stainless steel specific gravity measuring frame	
	Measuring Frame		
	Memory Mode	Dynamic memory	
	Result Display	Density value	
Result Testing Method	Distilled water testing		
Calibration Mode	Auto correction, auto detection.		
Standard Accessories	Common Use: Tweezer, thermometer, 100G weight, windshield, power transformer.		
	Solid Use: Tank, testing board, a set of particle measuring assembly, a set of floating body measuring assembly.		
	Liquid Use: Measuring plate, measuring frame, DE-20A standard liquid measuring assembly		
Optional Accessories	DE-40 printer, DE-20B anti corrosive liquid measuring assembly		
Power Supply	AC110/220V±10%, 50/60Hz		
Package Size(W*D*H)mm	450*200*360		
Gross Weight(kg)	6.5		

Precious Metal Tester



Application:

Distinguish K value of gold, PT value of platinum, density value, purity percentage can be measured. Pawning house, bank, jewelry shop, precious-metals recovery, jewelry factory, Gemstone Testing Center, precious metals researching, etc.
Note: Unable to measure sample which is hollow or with inserted gems.

Features:

- * Multi-mode, gold mode, platinum mode, other precious metals mode can be switched.
- * Top and bottom limitation of K value, purity and density of gold. And prompt alarm.
- * Automatic zero tracking, buzzer warning, and overload warning.
- * No damage testing, cleaning and environmental protection.
- * Could be used as precision balance.
- * Function of solution compensation: necessary if liquid other than water is used as a medium for measuring.
- * RS-232C is included.

Technical Parameters:

Model	BK-DMG300K	BK-DMG600K	BK-DMG900K	BK-DMG1200K	BK-DMG2000K
Capacity	0.005~300g	0.005~600g	0.01~900g	0.01~1200g	0.01~2000g
Density Resolution	0.001g/cm ³				
Measuring Time	10~15s				
Measuring Principle	Archimedes principle				
Testing Board	Unibody high-capacity plastic testing board				
Gold Mode	Display K Value	The K value of mixture of gold, silver, and copper; mixture of gold and copper; mixture of gold and silver			
	Display Purity Percentage	The purity content of mixture of gold, silver and copper; mixture of gold and copper; mixture of gold and silver			
	K Value Range	9K~24K			
	Copper and Silver Proportion Setting	Cycle setting depends on user's preference (default 7:3)			
Platinum	Display Value	PT percentage, density value, volume			
	PT Value Range	Pt600~Pt1000			
Measuring Tank	Unibody injection forming transparent professional measurement tank Size: 169*98*83mm (L*W*H)				
Calibration Mode	Auto correction, auto detection.				
Standard Accessories	Tank, testing board, tweezer, thermometer, weight, windshield, power transformer, a set of gold particle measuring assembly				
Option Accessories	DE-40 printer				
Power Supply	AC110/220V±10%, 50/60Hz				
Package Size(W*D*H)mm	450*200*360				
Gross Weight(kg)	6.5	6.5	6.5	6.5	6.5

High-precision Solid and Liquid Densimeter



BK-DMH120D

BK-DMH300D

Application:

It is suitable for the field of quality management, cost control, new materials researching, scientific academies, researching key laboratories, quality inspection, etc.

Any form of solid could be measured, including objects of hygroscopicity, non-absorbency, high-viscosity.

Measurement of special liquid such as volatile liquid, corrosivity liquid, strong acid and strong alkali liquid need optional accessory DE-20B anti corrosive liquid measuring assembly.

Features:

- * Automatically check whether density is qualified or not and prompt alarm.
- * Automatic zero tracking, buzzer warning, and overload warning.
- * Function of solution compensation: necessary if liquid other than water is used as a medium for measuring.
- * RS-232C is included.

Accessories for Densimeter

Standard Accessory:



DE-20A standard liquid measuring assembly

Optional Accessories:



DE-20B anti corrosive liquid measuring assembly



DE-40 printer

Technical Parameters:

Model	BK-DMH120D	BK-DMH300D
Capacity	0.001~120g	0.005~300g
Density Resolution	0.0001g/cm ³	0.001g/cm ³
Density Range	0.0001~99.9999g/cm ³	0.001~99.999g/cm ³
Measuring Time	About 5s	
Solid Mode	Measuring Principle	Archimedes principle
	Measurable Items	Density of general non-absorbency solid. Density of porosity materials. Oil length of oil bearing. Porosity of porosity materials. DIN volume abrasion loss of rubber. Powder density. Water absorption rate.
	Specific Gravity	Unibody injection forming professional specific gravity measurement frame Size: 135*50*116mm (L*W*H)
	Measuring Frame Measuring Tank	Unibody injection forming transparent professional measuring tank Size: 169*98*83mm (L*W*H)
	Mixed Material Percentage	Function introduction
Setting		Freely set the density value of main material and subordinate material
Display		Density value, percentage of main material
Liquid Mode	Measuring Principle	Archimedes principle displacement method
	Weight Value Data Storage	3 groups
	Specific Gravity Measuring Frame	Stainless steel specific gravity measuring frame
	Result Display	Density and Baume value
	Result Testing Method	Distilled water testing
Calibration Mode	Auto correction, auto detection.	
Standard Accessories	Common Use: Tweezer, thermometer, 100G weight, windshield, power transformer. Solid Use: Tank, testing board, a set of particle measuring assembly, a set of floating body measuring assembly. Liquid Use: Measuring plate, measuring frame, DE-20A standard liquid measuring assembly	
Optional Accessories	DE-40 printer, DE-20B anti corrosive liquid measuring assembly	
Power Supply	AC110/220V±10%, 50/60Hz	
Package Size(W*D*H)mm	450*200*360	
Gross Weight(kg)	6.5	

Electrophoresis System

Electrophoresis Power Supply



Application:

Suitable for common protein and nucleic acid electrophoresis, suitable for multiple tanks in one machine.

Features:

- * Display: Seven-inch large touch screen, convenient touch operation, automatic generation of digital keyboard when setting, display the clock timing temperature running status and various prompt operations.
- * Storage step by step: 10 programs can be edited and saved, and each program can be run in 10 steps.
- * Protection function: over current, overload, over temperature, no load, short circuit load mutation protection function.
- * Micro current: After the timing operation is over, the micro current output can be maintained when no one is shutting down.
- * Automatic setting: When one of the indicators of constant voltage, current and power, the other two items will automatically rise to the maximum value without manual adjustment.
- * Appearance: The appearance is tall and full of technology.

Technical Parameters:

Model	BEP-600D
Output	Constant-voltage or current or power(adjustable)
Output Range	5-600V; 1-1200mA; 5-300W
Increment	1V, 1mA, 1W
Timing	1min~99h59min
Parallel Output	4 groups
Temperature Check	-20°C~+85°C
Power Supply	AC220V±10%, 50/60Hz(standard); 110V±10%, 60Hz(optional)
External Size(L*W*H)	300*300*130mm
Package Size(L*W*H)	450*410*260mm
Gross Weight	3.6kg

Application:

The electrophoresis Power supply is a dedicated power supply device for electrophoresis. Be extremely careful when used in other occasions. In addition, the power supply of the electrophoresis instrument cannot be used in series or parallel with other charged equipment.



Features:

- * Large-screen LCD displays voltage, current, power and timing time at the same time.
- * Voltage, current and power closed-loop control, realizing adjustment during operation.
- * With call recovery function. * After reaching the set time, it has the function of maintaining small current.
- * Perfect protection and early warning functions. * With memory storage function.
- * One machine with multiple slots, four parallel outputs.

Technical Parameters:

Model	BEP-300I	BEP-600I
Voltage Output Range	2-300V(Resolution:1V)	5-600V(Resolution:1V)
Current Output Range	5-2000mA(Resolution:1mA)	4-600mA(Resolution:1mA)
Power Output Range	1-300W(Resolution:1W)	
Input Voltage	220V, 50/60Hz	
Parallel Output	4 groups	
Timing Function	1min-99h59min, adjustable	
External Size(L*W*H)	250*350*105mm	
Package Size(L*W*H)	440*330*210mm	
Net Weight	3.5kg	
Gross Weight	6kg	

Application:

Electrophoresis Power Supply is a special power supply equipment of electrophoresis, generally used for the separation, identification, purification and production of proteins, amino acids, nucleic acids, enzymes, peptides, hormones, pyrimidine, organics and inorganic. It can be used for multiple electrophoresis including DNA sequence analysis, isoelectric focusing electrophoresis(IEF).



Features:

- * Microprocessor control, large-screen LCD display.
- * High-performance switching power supply as the output core, high-power, strong load, high control accuracy, stable and reliable. * Voltage, current and power closed-loop control. Realizing adjustment during operation.
- * Protection function: overload, variable load, short circuit, open loop, overrun and other protection functions.
- * With 4 modes and memory storage function, 9 programs can be edited and saved. * With 2 parallel outputs.

Technical Parameters:

Model	BEP-3000I
Voltage Output Range	10-3000V(Resolution: 1V)
Current Output Range	3mA-300mA(Resolution: 1mA)
Power Output Range	5-200W(Resolution: 1W)
Input Voltage	220±10%V, 50/60 ±1 Hz, 400VA
Parallel Output	2 groups
Timing Function	1min~99h 59min, adjustable
External Size(L*W*H)	310*370*175mm
Package Size(L*W*H)	400*470*250mm
Net Weight	7.5kg
Gross Weight	9kg

Horizontal Electrophoresis Tank

Application:

Horizontal electrophoresis is a basic means in molecular biology research. It is widely used for DNA detection and separation, and molecular testing in the nucleic acid analysis, purification and preparation experiment.

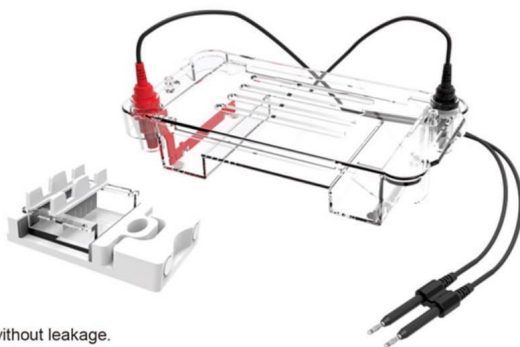

Features:

- * Polycarbonate is injection molded at one time without leakage.
- * The cooling hole design on the upper cover effectively avoids the condensation of water vapor.
- * Special telescopic elastic glue maker to ensure clean and no leakage of glue.
- * The limit function prevents the positive and negative electrodes from being reversed.
- * Highly flexible wire, power-off design when opening the cover to ensure safety.
- * The electrode head can be replaced for easy maintenance.
- * 99.99% high-purity platinum electrode, the best electrical conductivity, corrosion and aging resistance.
- * Recommended power supply: BEP-300I, BEP-600I, BEP-600D.

Technical Parameters:

Model	BK-HET01
Gel Trays(W*L)	75*60mm
Buffer Volume	300ml
Comb Thickness	1&1.5mm
Comb Throughput	6, 11 samples
NO. Of Samples	6~22
Standard Accessories	Body tank with electrode*1, Cap*1, Gel tray*1, Gel box*1, 1.0mm thickness 6/11 wells comb*2, 1.5mm thickness 6/11 wells comb*2
External Size(L*W*H)	180*90*70mm
Package Size(L*W*H)	290*290*200
Gross Weight	1.1kg

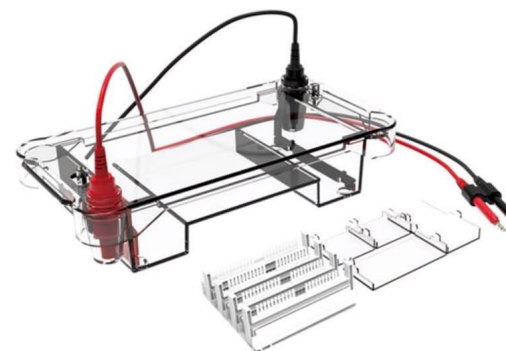

Application:

Horizontal electrophoresis is a basic means in molecular biology research. It is widely used for DNA detection and separation, and molecular testing in the nucleic acid analysis, purification and preparation experiment.

Features:

- * Polycarbonate is injection molded at one time without leakage.
- * Can make 4 kinds of different sizes of gel, two types of glue maker are optional.
- * The limit function prevents the positive and negative electrodes from being reversed.
- * Optional electrophoresis monitor can monitor the electrophoresis band in real time during the electrophoresis process.
- * The electrode head can be replaced for easy maintenance.
- * 99.99% high-purity platinum electrode, the best electrical conductivity, corrosion and aging resistance.
- * Recommended power supply: BEP-300I, BEP-600I, BEP-600D.

Technical Parameters:

Model	BK-HET02
Gel Trays(W*L)	120mm*120mm, 120mm*60mm, 60mm*120mm, 60mm*60mm
Buffer Volume	700ml
Comb Thickness	1&1.5mm
Comb Throughput	2, 3, 6, 8, 11, 13, 18, 25 samples
NO. Of Samples	2~50
Standard Accessories	Body tank with electrode*1, Cap*1, Gel tray*5, Gel box*1, 1.5mm thickness 2/3 wells comb*1, 1.0mm thickness 6/13 wells comb*1, 1.0mm thickness 8/18 wells comb*1, 1.0mm thickness 11/25 wells comb*4
External Size(L*W*H)	270*140*80mm
Package Size(L*W*H)	400*360*270mm
Gross Weight	2kg

Vertical Electrophoresis Tank

Application:

Vertical electrophoresis is used for separation, purification and preparation of nucleic acid and protein samples in life science research.

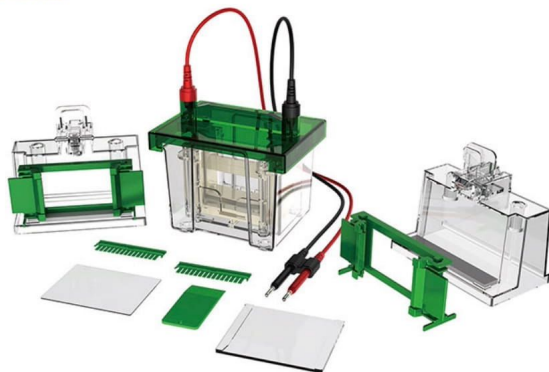

Features:

- * High-transparency polycarbonate injection molding, durable and easy to observe.
- * The integrated design of the glass cushion strip ensures that there is no leakage of glue.
- * The special glue making rack makes the glue making operation simple and reliable.
- * Open the cover and cut off the power to ensure the safety of the experiment.
- * The upper cover limit function ensures that the polarity of the electrode will not be connected incorrectly.
- * The power-off function of opening the lid ensures the safety of the experiment.
- * It can make double-board glue at the same time, with clear strips.
- * 99.99% high-purity platinum electrode, the best conductivity, strong corrosion resistance.
- * Recommended power supply: BEP-300I, BEP-600I, BEP-600D.

Technical Parameters:

Model	BK-VET01
Glass Tray (W*L)	Thick type: 101*83mm, thin type: 101*73mm
Gel Trays(W*L)	Hand glue: 83*73mm, precast glue: 86*68mm
Comb Thickness	Standard 1.0mm, optional 1.5mm
Comb Throughput	10, 15 samples
Amount of Gel	1~2 pcs
NO. of Samples	10~30pcs
Buffer Volume	700ml
Standard Accessories	Body tank *1, Cap*1, Electrode core*1 set, Gel casting base*2, Gel frame*2, Single glue baffle*1, Gel shovel*1, Glass plates*5 pairs, 1.0mm thickness 10 wells comb*2, 1.0mm thickness 15 wells comb*2
External Size (L*W*H)	150*120*130mm
Package Size(L*W*H)	400*350*300mm
Gross Weight	2.7kg

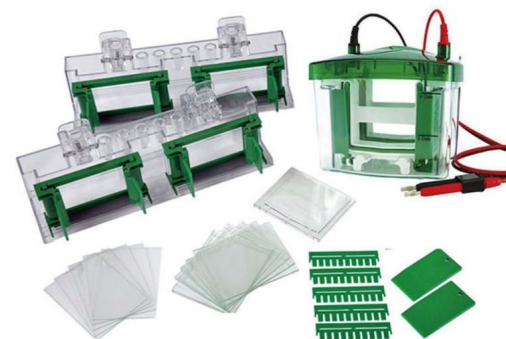

Application:

Vertical electrophoresis is used for separation, purification and preparation of nucleic acid and protein samples in life science research.

Features:

- * High-transparency polycarbonate injection molding, durable and easy to observe.
- * The integrated design of the glass cushion strip ensures that there is no leakage of glue.
- * The special glue making rack makes the glue making operation simple and reliable.
- * Open the cover and cut off the power to ensure the safety of the experiment.
- * The upper cover limit function ensures that the polarity of the electrode will not be connected incorrectly.
- * The power-off function of opening the lid ensures the safety of the experiment.
- * It can make double-board glue at the same time, with clear strips.
- * 99.99% high-purity platinum electrode, the best conductivity, strong corrosion resistance.
- * Recommended power supply: BEP-300I, BEP-600I, BEP-600D

Technical Parameters:

Model	BK-VET02
Glass Tray (W*L)	Thick type: 101*83mm, thin type: 101*73mm
Gel Trays(W*L)	Hand glue: 83*73mm, precast glue: 86*68mm
Comb Thickness	Standard 1.0mm, optional 1.5mm
Comb Throughput	10 samples
Amount of Gel	1~4 pcs
NO. of Samples	10~40pcs
Buffer Volume	1000ml
Standard Accessories	Body tank *1, Cap*1, Electrode core*1 set, Gel casting base*2, Gel frame*4, Single glue baffle*1, Gel shovel*1, Glass plates*5 pairs, 1.0mm thickness 10 wells comb*5
External Size (L*W*H)	180*130*130mm
Package Size(L*W*H)	400*350*300mm
Gross Weight	3.9kg

Western Blot Electrophoresis Tank

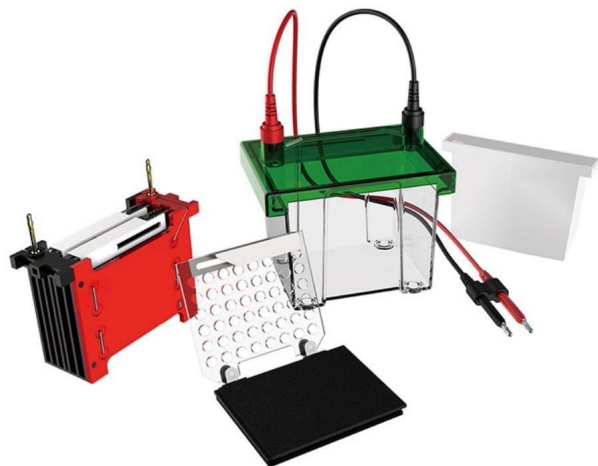

Application:

This product is a fast and high-quality transfer operation for small protein gels.

Features:

- * The positive electrodes are gathered together 4cm to generate a strong electric field for effective protein transfer.
The built-in ice box or blue crystal ice box is optional to quickly absorb the heat generated during the electrophoresis process.
- * Use with BK-VET01, BK-VET02.
- * Highly flexible wire, power-off design when opening the cover to ensure safety.
- * The electrode head can be replaced for easy maintenance.
- * 99.99% high-purity platinum electrode, the best electrical conductivity, corrosion and aging resistance.
- * Recommended power supply: BEP-300I, BEP-600I, BEP-600D.

Technical Parameters:

Model	BK-TET01
Transfer Gel Area (W*L)	110*90mm
Buffer Volume	700ml
Standard Accessories	Body tank *1, Cap*1, Transfer core*1 set, Transfer clip*2, Sponge cushion*4, Ice box*1
External Size (L*W*H)	150*120*130mm
Package Size(L*W*H)	290*290*200mm
Gross Weight	1.3kg

UV Transilluminator



Function Overview:

The function of the ultraviolet analyzer is to be used for fluorescence analysis: when a material molecule in the ground state is exposed to excitation (ultraviolet light), it absorbs the excited energy and the material molecule is in the excited state.

Features:

- * Equipped with a fixed camera port rack, the instrument is suitable for most SLR cameras on the market.
- * With anti-ultraviolet observation window filter 99% ultraviolet, real-time observation of the sample situation, more intuitive, more safe.
- * Nano medical ultraviolet lamp, the ultraviolet intensity of 20μW/cm away from the sample, in line with the measurement standard.

Technical Parameters:

Model	BK-UA2
UV Lamp	6W*10pcs
Reflection Wavelength	254nm, 365nm
Transmission Wavelength	302nm
Visible Light	60W
Reflective Filter Size	200*80mm
Transmission Filter Size	200*150mm
UV Intensity	Ultraviolet intensity of 20cm away from the sample reaches 20μW/cm ²
Power Supply	220V, 50Hz
Packing Size	480*395*535mm
Gross Weight	7kg

Automatic Gel Imaging and Analysis System

Introduction:

Automatic Gel Imaging and Analysis System is a highly integrated and fully automated gel imaging system, system interface is simple and practical, the main interface has shooting button and time control to guide the user, it is very easy to operate, no need to have manual and tedious debug, it is your best choice.

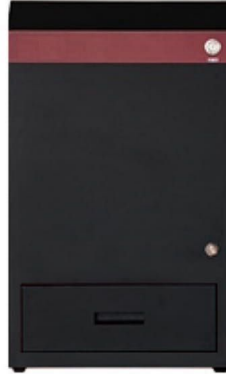

Features:

High-resolution CMOS camera, high sensitivity, high resolution, with automatic focus and high performance 6 times lens, specialized filter for nucleic acid dye.



CMOS Camera



Autofocus Lens



Multilayer Coating Filter

Specialized overlay glue cutting filter, compared with the traditional one, it has many advantages, easy to operate, can prevent UV and blue light damage, no need to operate in dark room, work very well under strong light condition. The white light sample plate is used for SDS-PAGE glue samples shooting.



UV sample plate



Glue Cutting Filter

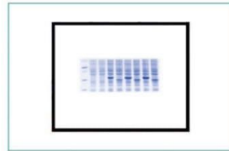

White Sample Plate

Application:

It can be used to do nucleic acid test for various fluorescent dyes, such as EB, SYBRGold, SYBR Green, SYBR Safe, Gel Red Gel GreenTexas, Red, Fluorescein marked DNA/RNA.

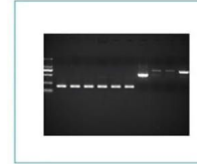

DNA Gel Imaging

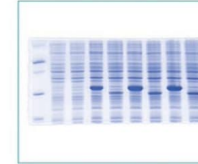

SDS-PAGE Imaging

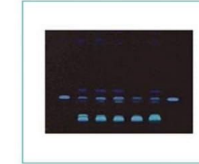

Thin-layer Chromatography



Colony Counting

Technical Parameters:

Mode	BK-AG100
Pixel	2592*1944(5.03MP)
Exposure Time	1ms-3000ms
QE Value	High QE: >65%
Binning	1*1
Bit Depth	16 bit (0 - 65535)
OD	≥4.8 OD
Lens	Motorized 8-48 mm, F1.2
Trans-UV	302nm
Epi-White	LED
Trans-White	UV to white sample plate
Epi-UV	254nm、302nm、365nm
Filters	590nm, Others for option
UV Area	21*21cm
Timing Off	1~60 mins
Power Supply	100-240V, 50/60Hz
Packing Size	460*475*725mm
Gross Weight	31kg

Automatic Chemiluminescence Imaging System

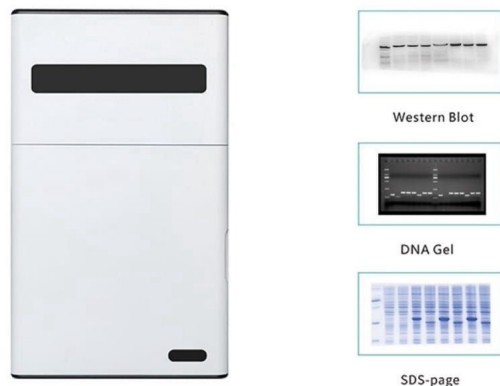

Applications:

Nucleic acid detection: EB, SYBRGold, SYBRGreen, SYBRSafe, GelRed, GelGreen, Fluorescein.

Protein test: Silver dyeing, SDS-page, Visible light imaging.

Luminescence detection: Western Blot, Western Lightning, ECL, ECLplus

Features:

- * Fully automatic control of the lens and light source
- * Precise automatic exposure in calculate, no need to repeat calculation the exposure time
- * One button shooting, marker and chemiluminescence image automatic stacking
- * Cryogenic scientific research ultrasensitive CCD camera, wide aperture Lens

Technical Parameters:

Model	BK-ACG600	BK-ACG900
Camera Resolution	9.0MP	12.0MP
Cooling Temperature	-65°C	
Photosensitive Efficiency	> 75%	> 95%
Pixel Size	3.75*3.75um	4.63*4.63um
Exposure Time	1ms-120min	
Pixel Density	16 Bits (0-65535)	
OD	≥4.8OD	
Lens	Standard: F=0.95, 25mm; optional: F=0.8, 25mm	
UV Transmission	302nm	
White Light Reflection	LED reflection (cold light)	
Filter	Standard 590nm, other optional	
Shooting Area	16×14cm	
Timer Shut Down	1-60min	
Power Supply	100-240V 50/60Hz	
Packing Size	490*515*845mm	
Gross Weight	40kg	

Integrated Automatic Gel Imaging System

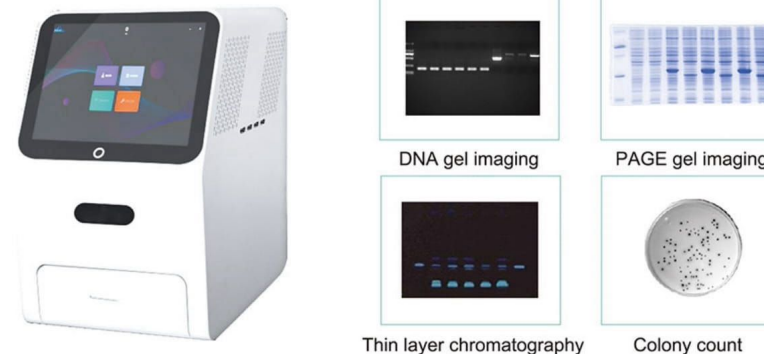

Applications:

Nucleic acid detection with various fluorescent dyes such as EB, SYBR Gold, SYBR Green, SYBR Safe, Gel red Gel, Green Texas Red, Fluorescein labeled DNA/RNA, etc.

Features:

- * Camera lens, adopt dark field camera module F 1.0 Super aperture 20 million Solutions Analyticity.
- * Touch system 12.5 inches touch HD display, one touch imaging, intelligent processing system.
- * Special filter, multilayer coated filter is adopted passing of absolute stray light.

Technical Parameters:

Model	BK-AGX3
Camera Resolution	6.0MP
Photosensitive Efficiency	≥79%
Exposure Time	1ms-5000ms
Pixel Density	16 Bits (0-65535)
OD	≥4.8OD
Lens	Large aperture autofocus lens F=1:1.2, 20 million auto focus lens
UV Transmission	302nm, optional other transmitted blue light
White Light Reflection	LED reflection (cold light)
White Light Transmission	White light conversion sample board
Filter	Standard 590nm, other optional
Shooting Area	21×21cm
Timer Shut Down	1-60min
Touch System	12.5-inch touch system
Power Supply	110-240V, 50/60Hz
Packing Size	450*462*666mm
Gross Weight	22.3kg

Eye Washer

Deck Mounted Eye Washer



EW-DM1



EW-DM2



EW-DM3

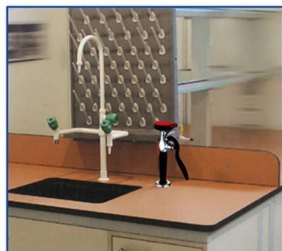

Max. working pressure: 7Bar

Valve: None-return valve, shut off automatically

Hose: Length 1.4m, PVC with stainless steel net

Sprayer head: Soft rubber, softened water spray for eye protection

Dust shield cap: PP, removed automatically when eye washer is operated

Switch: Automatic trigger locking for easy hand-free use

Material: Solid thick brass with high gloss epoxy powder, resistant to chemicals, UV and heat.

Technical Parameters:

Model	EW-DM1	EW-DM2	EW-DM3
Package Size(W*D*H)mm	270*170*80	440*240*120	270*170*80
Gross Weight(kg)	1	2	1

Wall Mounted Eye Washer

Material: 304 stainless steel with Exquisite polished / Epoxy coating stainless steel with high gloss epoxy powder, resistant to chemicals, UV.

Eye washer bowl: stainless steel / PP bowl, water bore is made of PP(ABS shield cap), safe green, installing conveniently.

Sprayer head : water bore has been treated with; make the water more mild and abundant.

Switch: the sign of operation is near by the knob, operate simply.

Package Size(W*D*H)mm: 470*420*350

Gross Weight(kg): 8.5



EW-WM1

Wall Mounted Shower Eye Washer



S-WM2



S-CM3



SEW-WM1

Sprayer head: The flux of spray head shower&washer is ample, installing conveniently, saving space.

Tube: Stainless steel material, making the products firm and high quality, resistant to the chemicals.

Switch: The sign of operation is near by the knob, operate simply.

Technical Parameters:

Model	S-WM2	S-CM3	SEW-WM1
Package Size(W*D*H)mm	820*270*160	960*340*140	1320*440*320
Gross Weight(kg)	5.5	5	18

Combination Emergency Shower Eye Washer



Material: Stainless steel, firm and chemical resistant.

Eye washer is suitable for cleaning eyes, face and hands; the spray head can be use of washing the whole body.

Switch of the spray shower is controlled by the top of the handle, the flow is steady and ample.

Height of the bowl is condign, couple water bores humanistic design, the heigh and angle design is according to the proportion of the face.

Outlet water bore has been handled, making the water more mild, in order to protect the eyes from being harmed.

Valve-switch make the operation simple, when using only to touch the knob.

Drain directly, the used water flow directly through the tube which is in the bowl, no pollution.

Technical Parameters:

Model	SEW-C1	SEW-C2
Package Size(W*D*H)mm	1310*380*250	1310*350*440
Gross Weight(kg)	17.5	20

Fiber Analyzer

Application:

BK-F800 Fiber Analyzer is with advanced design, easy operation and flexible application. It can be used in conventional Weende method to analyze crude fiber and Van Soest analysis to wash the fiber. Applies to plant, feed, food and other agricultural products as well as the determination crude fiber, neutral detergent fiber (NDF), acid detergent fiber (ADF), hemicellulose and acid detergent lignin (ADL)

Features:

- * Hidden solution barrel pull structure designed to facilitate dosing operation, provide the safest fiber analysis.
- * Corrosive liquid is not in contact with any pump body, to avoid waste discharge pump susceptible to corrosion phenomena.
- * The crucible recoil function designed to prevent sample in the crucible can not caking filtration.
- * With dosing overflow protection function to prevent dosing corrosive liquid overflow due to operator error, protect the safety of the operator.
- * Adjust the crucible heating power in time, enabling operator to control the heating rate easily and low down the energy consumption, ECO-friendly.
- * Having a built-in pre-heating function, greatly reducing the whole experiment time.
- * Provide five various specifications crucible specifications to meet the needs of different samples for standard configuration.



Technical Parameters:

Model	BK-F800
Measurement Range	0.1%~100%
Sample Weight	0.5~3g per piece
Repeatability	≤0.4% (Craw Fiber Content below 10%) ≤1% (Craw Fiber Content above 10%)
Max. Capacity	6 pcs/batch
Pre-heating Time	10~12min
Heating to Boiling	13~15min
Consumption	2.2KW
Power Supply	AC220V±10%, 50Hz
External Size(W*D*H)	776*476*644mm
Package Size(W*D*H)	Main Body:680*950*840mm / Accessories:480*340*250mm
Gross Weight	Main Body:114kg /Accessories:4.6kg

Fiber Analyzer



F series crude fiber tester is a high-throughput, high-efficiency, easy-to-operate automatic crude fiber tester developed by using the three-dimensional filter bag method, combined with no cooling water, high-pressure sealing technology and modern electronic technology. It is suitable for the analysis of crude fiber in feed, food, dairy tobacco and other industries by CF, NDF, ADF, ADL methods

Features:

- * Large screen man-computer interaction interface, 16-bit true color LCD touch screen, simple and easy to use operation interface, easy for users to learn and use.
- * Built-in settable experimental protocol, a total of 50 different experimental protocols can be set.
- * Built-in user login function, a total of 5 user accounts.
- * Built-in user account permission setting, each login account can set its own operation authority, different levels of operation authority can operate the machine function is different.
- * Fingerprint login function, no need to enter the user name and password, you can log in using the entered fingerprint information, which is more convenient and fast.
- * Built-in instrument functional parts detection function, all movable working parts inside the instrument have corresponding detection switches on the screen, which is convenient for daily maintenance of users.
- * Special treatment reactor, the reactor body is made of special material, high temperature resistance, high pressure and chemical corrosion, long service life.

- * Reactor anti-dry burning function, built-in software and hardware double anti-dry burning insurance to prevent dry burning of the kettle body.
- * Reactor airtight self-inspection technology, the reactor can carry out airtight self-inspection during the experiment to prevent the reactor cover from being tight.
- * Foam structure design, unique cooking structure can effectively prevent the foam generated when the reagent is heated, and there is no need to add n-octanol and other defoamers, saving reagents and more environmentally friendly and odorless.
- * High-power heating aluminum block is used to improve heating efficiency.
- * Closed cooking technology, the steam generated during the experiment will not diffuse outside the equipment, and the micro-boiling boiling function that does not require cooling water for cooling is realized, and the equipment is more convenient to use.
- * Precise temperature control technology, high-precision temperature sensor installed inside the reactor, precise control of the reagent to a micro-boiling state, good experimental effect.
- * Reactor internal pressure detection alarm function, the equipment experiment can automatically detect the pressure state inside the reactor, once the temperature is too high and the pressure is too high, the alarm will be automatically generated and the experiment will be paused, and the alarm interface will automatically pop up on the screen.
- * Experiment completion prompt function, once the whole experiment is completed, the device will automatically generate a beep sound to prompt, and the prompt interface for the completion of the experiment will be displayed on the screen.
- * Built-in 3 kinds of fiber result calculation formula and printer, no manual calculation, input parameters can print the test results.

Technical Parameters:

Model		BK-F1600	
Processing temperature range	Room temperature -100°C;	Sample batch capacity	1-24
Sampling amount/bag	0.5-1.5g	Adding method	Manual
Fiber test range	0.1-100%	Temperature control accuracy	±0.2°C
The cooking time setting of each stage	0-999min		
Repeatability accuracy	if the fiber content is less than 10%, the relative deviation is ≤5%; if the fiber content is greater than 10%, the relative deviation is ≤3%;		
Daily processing capacity	24-96 pieces of crude fiber, 24-120 pieces of neutral detergent fiber/acid detergent fiber/lignin (8-hour working system)		
Net	Size(mm)	560*430*510	
	Weight(kg)	28	
Package	Size(mm)	660*500*590	
	Weight(kg)	44	

Fat Extractor



Introduction:

Fat Extractor(also known as automatic Soxhlet extractor, crude fat analyzer), mainly by heating extraction, solvent recovery, cooling three parts. Each heating tank can adjust the heating temperature and time independently according to the different boiling point of the reagent, and the sample is repeatedly soaked and extracted by the reagent to achieve the purpose of rapid extraction.

Application:

Mainly used for extracting food, grain, feed, oil, soil, wool grease and other samples.

Features:

- * 7 inch LCD touch screen display control.
- * Integrated metal bath heating system ensures that each sample can be operated independently.
- * Cast aluminum heating module, fast heating speed, fast reflux speed.
- * With heating extraction, solvent recovery function, saving experimental supplies.
- * Built-in circulating water pipeline, easy to operate.
- * With overvoltage, overheating, leakage multiple protection devices.
- * Reserve heating function, reserve opening time.

Technical Parameters:

Model	BKXET02C	BKXET04C	BKXET06C
Capacity	2pcs	4pcs	6pcs
Sample Weight	0~100g		
Temp. Range	RT.~250°C		
Solvent Cup Volume	250ml		
Power Supply	220V 50Hz		
Heating Way	Dry independent heating		
Device	Condensing recovery device, overheating protection device		
External Size	330*410*850mm	532*410*850mm	750*410*850mm
Package Size	435*515*995mm	640*515*995mm	855*515*995mm
Net Weight	14kg	17kg	25kg
Gross Weight	23kg	28kg	37.5kg

Fat Analyzer



Applications:

The water bath fat analyzer is a commonly used instrument for food, oil, feed and other industries to measure fat content by gravimetric method based on Soxhlet extraction principle. This instrument is mainly composed of three parts: heating and soaking extraction, solvent recovery and cooling. It dissolves fat in organic solvent, separates fat from solvent by extraction method, and then calculates the fat content after drying and weighing. During operation, the heating temperature can be adjusted according to the boiling point of the reagent and the ambient temperature. The sample is soaked and extracted repeatedly during the extraction process, so as to achieve the purpose of rapid determination.

Features:

- * Digital temperature control, timing, and alarm when the time comes
- * The heating power can be adjusted arbitrarily, and the heating temperature can be adjusted according to the boiling point of the reagent and the ambient temperature
- * Adopt ground glass junction and PTFE sealed switch, high reagent recovery rate
- * Stainless steel water bath Teflon coating treatment, anti-corrosion, anti-rust, durable and beautiful
- * Small size, fast heating speed in water bath, good heating uniformity
- * Self-flowing liquid addition, reagent extraction is smooth
- * One-piece design, the reagent container is placed on the table, easy to add liquid
- * The circuit and liquid circuit are completely isolated to enhance system security

Technical Parameters:

Model	SFA-06
Control Temp. Range	RT+5 to 100°C
Measuring Range	0.1 to 100%
Control Temp. Precision	±1°C
Sample Weight	0.5 to 20g
Capacity	6pcs/batch
Solvent Cup Volume	500mL
Solvent Recovery	≥85%
Measuring Time	The extraction time is adjustable, and the alarm will be issued when the time comes
Power	1.4KW
Power Supply	Standard: 220V 50/60Hz, optional: 110V 50/60Hz
External Size	740*260*660mm
Net Weight	25kg
Packing Size	885*390*905mm
Gross Weight	50kg

Fat Analyzer

Applications:

It is widely used in the determination of fat products in the fields of grain, feed, oil, food processing, chemical industry, animal husbandry, soil and fertilizer environmental monitoring, medicine, agriculture, scientific research, teaching, quality supervision and other fields with crude fat content >0.1%.

Features:

- * The whole metal bath heating module is used for heating, which has a wide temperature control range and high temperature control accuracy.
- * The circuit and extraction space are completely isolated to enhance system security.
- * The instrument has a complete duration control system to strictly control the experiment.
- * With over-temperature alarm and timing reminder functions
- * Multiple alarm systems such as sound and LCD text prompts
- * The lifting connection of linear bearing transmission technology makes the lifting operation flexible and free.
- * Intelligent human-machine dialogue control system
- * Air layer insulation technology keeps the body shell at normal temperature and has the dual functions of heat insulation and heat preservation
- * Adopt 7-inch LCD display and microcomputer control system

Technical Parameters:

Model	SFA-06S
Temp. Control Range	RT+5 to 280°C
Measuring Range	0.1% to 100%
Temp. Control Precision	±1°C
Measuring Sample Weight	0.5 to 20g (normally 2 to 5g)
Batch No.	6 pcs
Solvent Volume	80ml
Solvent Recovery Rate	≥85%
Measuring Time	Extraction time is adjustable
Rated Power	1000W
External Size	650*320*680mm
Net Weight	35kg
Power Supply	Standard: 220V 50/60Hz; optional: 110V 50/60Hz
Packing Size	730*400*760mm
Gross Weight	50kg



Introduction:

According to the principle of Soxhlet extraction, the fat content of grain, grain and food was determined by gravimetric method. The product is fully automatic one-key operation design, easy to operate, stable performance, high accuracy, with: Soxhlet extraction, hot extraction, Soxhlet hot extraction, continuous flow and standard hot extraction and other automatic extraction mode.

Features:

- * 7 inch color touch screen friendly interface design, convenient and easy to learn.
- * Program editing is intuitive, easy to operate, can be used repeatedly.
- * 99 different analysis programs can be stored.
- * Up to 40 procedures, multi-temperature, multi-cycle soaking, extraction, heating.
- * Complete the whole process of pressing, heating, soaking, extraction, reflux, valve opening and closing by one key.
- * Automatic lifting and pressing system is highly automatic, reliable and convenient.
- * Solenoid valve point opening and closing, timing opening and closing, manual opening and closing can achieve a variety of ways of soaking, extraction.
- * Using integral metal heating block, with a wide temperature range, high temperature control accuracy.
- * The automatic lifting function of the extraction filter paper cup holder ensures that the sample is immersed in organic solvent at the same time, which helps to improve the consistency of the sample determination results.
- * Professional customized components are suitable for all kinds of organic solvents, including petroleum ether, ether, alcohols, imitation and other organic solvents.
- * Oil ether leakage alarm, when the working environment is dangerous due to oil ether leakage, the alarm system starts and stops heating.
- * Equipped with aluminum alloy and glass two kinds of solvent cup for users to choose.

Technical Parameters:

Model	SFA-06E
Temp. Range	RT+5~300°C
Measuring Range	0.1~100%
Temperature Accuracy	±1°C
Sample Weight	0.5~15g
Capacity	6pcs/batch
Solvent Cup Volume	150ml
Solvent Recovery	85%
Solvent Backflow Control	Solenoid valve
Lifting System	Automatic
Display	7 inch color touch screen
Consumption	1500W
Power Supply	AC 220V+10%, 50/60HZ
External Size(W-D'H)	730*280*810mm
Net Weight	48kg
Package Size(W*D*H)	790*380*1160mm
Gross Weight	63kg



Chromatograph Gas Chromatograph

Features:

- * 7-inch LCD display indicates temperature, gas flow and heating curve.
- * Self-test function and automatic fault recognition function.
- * 8 pcs external extension interfaces can connect with control valve.
- * Equipped with a flame ionization detector (FID).
- * Multi-core and 32-bit embedded hardware system ensures the reliable operation.
- * Synchronous external trigger function and the external signal (auto sampler, thermal analyzer, etc.) can start the equipment and workstation software at the same time.
- * With chromatography workstation software to process data.
- * Memory function: can store 20 sample test modes.
- * One key start up function.



Technical Parameters:

Model	BK-GC112A	
Oven	Capacity	22L
	Temp. Range	RT+5°C~400°C
	Temp. Accuracy	±0.1°C
	Temp. Program	9 step
	Program Total Time	9999.9 min
	Max Temp. Heating Rate	60°C/min
Sample Injector	Temp. Range	RT+7°C~420°C
	Column or split injector can be installed	
	Carrier gas flow control type: Constant pressure mode	
	Max. Quantity	3pcs
	Pre Column Pressure Range	0-400kpa
	Pre Column Pressure Accuracy	0.1kpa
	Flow Setting Range	H2: 0-200ml/min N2: 0-150ml/min
Detector	Temp. Range	RT+7°C~420°C
	Hydrogen Flame Ionization Detector (FID)	Logarithmic amplifier
		High voltage switch control
		Baseline signal display
		Detection limit: ≤3*10 ⁻¹² g/s (Sample: n-hexadecane)
		Baseline noise: ≤5*10 ⁻¹⁴ A
		Baseline draft: ≤6*10 ⁻¹³ A
	Thermal Conductivity Detector (TCD)(Optional)	Dynamic range: 10 ⁷
		RSD: ≤3%
		Sensitivity: 8000mv.ml/mg(Sample: n-hexadecane)
Dynamic range: 10 ⁵		
Power Supply	AC220V±10%, 50Hz	
Standard Accessory	FID detector, Capillary injection system, Chromatography workstation software, RS232 port, LAN port	
Optional Accessory	TCD detector, Chromatographic column, Gas purifier	
Package Size(W*D*H)	735*725*835mm	
Gross Weight	80kg	

Features:

- * 5.7-inch LCD display indicates temperature, time and gas flow.
- * Can install packed column and capillary column at the same time
- * Self-test, power protection, keyboard lock, automatic ignition and anti power mutation interference function.
- * With chromatography workstation software to process data.
- * Equipped with a flame ionization detector (FID), and TCD, ECD, FPD, NPD are optional. Can install 3 detectors at the same time.
- * Can connect with Internet, realize data transfer and program upgrade automatically.
- * Double column compensation function, which can effectively restrain baseline drift and the influence of background noise.
- * Large capacity oven (300*280*180mm) can hold 2 pcs 0.32mm diameter capillary column (length: 80m).
- * Better thermal insulation effect: when the temp. of oven, vaporizing chamber and detector reach 300°C, the max. temp. of outer chamber is 40°C.



Technical Parameters:

Model	BK-GC7820	
Oven	Temp. Range	RT~450°C
	Temp. Accuracy	±0.1°C
	Temp. Program	16-phase
	Max. Temp. Heating Rate	40°C/min
Detector	Hydrogen Flame Ionization Detector (FID)	Detection limit: ≤3*10 ⁻¹² g/s(Sample: n-hexadecane)
		Baseline drift: ≤1*10 ⁻¹³ A/30min
		Linear range: ≥10 ⁷
	Thermal Conductivity Detector (TCD) (Optional)	Sensitivity: >10000mv.ml/mg(Sample: n-hexadecane)
		Linear range: ≥10 ⁵
	Electron Capture Detector (ECD) (Optional)	Detection limit: ≤1*10 ⁻¹⁴ g/ml(Sample: n-hexadecane δ-666)
Detector	Flame Photometric Detector (FPD) (Optional)	Detection limit: ≤2*10 ⁻¹¹ g/s(S of thiophene)
		Detection limit: ≤1*10 ⁻¹² g/s(P of methyl parathion)
		Linear range (S): ≥10 ³
		Linear range (P): ≥10 ⁴
Nitrogen and Phosphorus Detector (NPD) (Optional)	Detection limit: ≤1*10 ⁻¹² g/s(Azobenzene)	
	Detection limit: ≤1*10 ⁻¹² g/s(Marls sulphur phosphorous)	
	Linear range: ≥10 ³	
Power Supply	AC220V±10%, 50/60Hz(Optional)	
Standard Accessory	FID detector, Chromatography workstation software, Capillary sampler	
Optional Accessory	Sample injection system, TCD, ECD, FPD and NPD detector, Chromatographic column	
Package Size(W*D*H)	820*670*600mm	
Gross Weight	71kg	

Gas Chromatograph



Introduction:

BK-GC900 gas chromatograph is a popular, high-performance, multi-functional series of chromatographic instruments. FID, TCD detectors can be combined as needed to meet the needs of ordinary laboratories, daily production, routine detection and trace quantities analysis requirements. It can be widely used in many fields such as petroleum, chemical industry, environment, food safety, disease control, teaching and scientific research.

Features:

- * Ethernet communication interface is adopted, so that the instrument can realize long-distance data transmission through the internal LAN of the enterprise, which is convenient for the management of analysis data.
- * The unique design of the injection port solves the injection discrimination, and the dual-column compensation function not only solves the baseline drift caused by temperature programming, but also reduces the influence of background noise, which can lead to lower detection limits.
- * Unique vaporization chamber design, smaller dead volume; replacement of accessories such as injection pad, liner, polarizer, collector, nozzle can be done with one hand; packed column, capillary injector, TCD, FID detector and other main bodies. The replacement only requires a wrench to be completely disassembled, and the maintenance is very convenient.
- * The intelligent rear door system has stepless variable inlet and outlet air volume, which shortens the stable balance time of the system after programmed heating/cooling.

- * The inlet can be installed up to 4 types (packed column, capillary column split/splitless injection system can be used), multiple detectors with the same or different detectors are installed, automatic/manual gas injection device can be selected, top Empty sampler, thermal desorption sampler, pyrolysis furnace sampler, methane reformer, etc.
- * The instrument is equipped with a 4.3-inch color LCD touch screen and keyboard input for user operation.
- * Adopt the dual-stable gas path design of primary pressure stabilizer valve and stabilizer valve/pressure stabilizer valve
- * With seven temperature control devices, the temperature control accuracy is lower than $\pm 0.1^{\circ}\text{C}$
- * With double over-temperature protection and power-off protection function
- * With linkage trigger signal acquisition system
- * With fault self-check and alarm function

Technical Parameters:

Model	BK-GC900	
Oven	Temp. Range	RT+5~450°C
	Temp. Accuracy	$\leq \pm 0.1^{\circ}\text{C}$
	Temp. Program	20-phase
	Max. Temp. Heating Rate	40°C/min
	Time Range	0-655min
	Internal Size	250*270*170mm
Detector	Hydrogen Flame Ionization Detector (FID)	Detection limit: $\leq 5 \times 10^{-12}\text{g/s}$ (100ng/ul n-hexadecane-isooctane solution)
		Temperature 450°C
		Compatible with packed and capillary columns
		Baseline drift: $\leq 2 \times 10^{-13}\text{A/30min}$
	Thermal Conductivity Detector (TCD)	Baseline noise: $3 \times 10^{-14}\text{A}$
		Linear range: $\geq 10^7$
		Sensitivity: $> 5000\text{mv.ml/mg}$ (50mg/ml toluene-benzene solution)
		Temperature 400°C
	Baseline drift: $\leq 0.1\text{mV/30min}$	
	Baseline noise: 0.03mV	
	Linear range: $\geq 10^5(\pm 10\%)$	
Injection Method	Various injection methods are available: (1) Packed column injection; (2) Packed column gasification injection; (3) Capillary split/splitless injection: back pressure valve control technology, linear split; (4) Six-way valve gas injection; (5) On-line injection: continuous injection for 24 hours without supervision	
Power Supply	AC220V $\pm 10\%$, 50/60Hz	
Standard Accessory	FID detector, Chromatography workstation software, Capillary sampler	
Optional Accessory	Sample injection system, TCD detector, Chromatographic column, Nickel catalytic converter	
External Size(L*W*H)	530*502*508mm	
Net Weight	42kg	
Package Size (W*D*H)	750*710*720mm	
Gross Weight	60kg	

Gas Chromatograph

Introduction:

BK-GC901 gas chromatograph can realize full EPC electronic flow control, realize full computer control of the instrument, and can be equipped with a high-precision liquid automatic sampler. It can be widely used in many fields such as petroleum, chemical industry, environmental protection, food safety, disease control, education and scientific research, and can analyze the macro, micro and trace amounts of organic matter, inorganic matter and gas.



Features:

High-precision gas flow control system (EPC)

- * High-precision gas flow control, to ensure the accuracy of GC analysis, to ensure the efficiency of daily analysis, EPC control accuracy 0.01psi.
- * It realizes the self-protection of gas circuit failure, automatic ignition, re-ignition, automatic opening of the gas circuit, and one-key start.
- * A variety of control combination modes of operation, automatic pressure and flow adjustment, control and display, can operate in gas-saving mode.

Color widescreen, unique design of touch keys

- * 7-inch industrial color LCD screen design, more complete display information, more reasonable interface operation.
- * Have two sets of operating systems in Chinese and English to meet different user needs.
- * Adopt resistive touch screen, feel good, durable, double operation of screen and software to achieve seamless connection.

Leading structural design

- * Modular structure design, easy to upgrade, can be equipped with a variety of high-performance detectors such as FID, TCD, ECD, FPD and NPD, etc., to meet the analysis needs of complex samples.
- * Advanced sampler design, unique liner structure and special processing technology to ensure zero adsorption of samples.
- * Adapt to a variety of sample injection methods such as: headspace sampler, thermal desorption analyzer, liquid automatic sampler, easily competent for the analysis of various sample types.
- * Timed self-starting program can easily complete the laboratory online analysis of gas and liquid samples.

Humanized software operating system

- * Adopt advanced 10/100M self-adaptive Ethernet communication interface, built-in IP protocol stack, easily form a local area network, realize long-distance transmission, remote control, and remote diagnosis.
- * Equipped with IBrainChrom workstation, which can support multiple chromatographs (253 sets) to work at the same time, realize data processing and reverse control.

Data processing and countermeasures

- * Have complete audit trail, user rights management, electronic signature and other functions, so that data and documents meet GMP management requirements.
- * The built-in Modbus/TCP server of IBrainChrom workstation can easily connect the analysis results to DCS (distributed control system).
- * 3 independent connection threads that can be connected to local, laboratory supervisors and authorities, allowing them to monitor the operation of the instrument and analyze the data in real time.

Technical Parameters:

Model	BK-GC901	
Oven	Temp. Range	RT+5~450°C
	Temp. Accuracy	±0.01°C
	Temp. Program	16-phase
	Max. Temp. Heating Rate	40°C/min
	Time Range	0-999.9min
Detector	Hydrogen Flame Ionization Detector (FID)	Detection limit: ≤5*10 ⁻¹² g/s (100ng/ul n-hexadecane-isoctane solution)
		Temperature 450°C
		Compatible with packed and capillary columns
		Baseline drift: ≤2*10 ⁻¹³ A/30min
	Thermal Conductivity Detector (TCD)	Baseline noise: 3*10 ⁻¹⁴ A
		Linear range: ≥10 ⁷
		Sensitivity: >5000mv.ml/mg (50mg/ml toluene-benzene solution)
		Temperature 400°C
	Electron Capture Detector (ECD)	Baseline drift: ≤0.1mV/30min
		Baseline noise: 0.03mV
		Linear range: ≥10 ⁵ (±10%)
		Detection limit: ≤1*10 ⁻¹⁴ g/ml (Sample: n-hexadecane δ-666)
Flame Photometric Detector (FPD)	Linear range: ≥10 ⁴	
	Detection limit: ≤5*10 ⁻¹² g/s (S of 10ng/uL methyl parathion-ethanol solution)	
	Detection limit: ≤4*10 ⁻¹² g/s (P of 10ng/uL methyl parathion-ethanol solution)	
	Linear range (S): ≥10 ³	
Nitrogen and Phosphorus Detector (NPD)	Linear range (P): ≥10 ⁴	
	Temperature 350°C	
	Detection limit: ≤1*10 ⁻¹² g/s (Azobenzene)	
Injection Method	Detection limit: ≤1*10 ⁻¹² g/s (Marla sulfur phosphorous)	
	Linear range: ≥10 ³	
Inlet	Capillary column split/splitless sampling (with diaphragm purging function), packed column sampling, valve sampling, gas/liquid automatic sampling system, etc.	
Injection Type	1~4, up to 3 capillary column inlets	
Control Accuracy	Packed column injection, capillary column injection. (Flow setting range: 0~1000mL/min)	
Maximum Split Ratio	Pressure: 0.01KPa; Flow 0.01mL/min	
Pressure Sensor	1:999	
Flow Sensors	Accuracy: <2% of full scale; Repeatability: ±0.05KPa; Range: 0~0.6MPa	
Sampling Valve	Accuracy: < 5% of full scale; Repeatability: 0.5K Pa (full scale); Output offset (accuracy): ±5%	
Power Supply	Can be equipped with multiple imported automatic control valves, which can run automatically in sequence	
Standard Accessory	AC220V±10%, 50/60Hz	
Optional Accessory	FID detector, Chromatography workstation software, Capillary sampler	
Package Size (W*D*H)	Sample injection system, TCD, ECD, FPD and NPD detector, Chromatographic column.	
Gross Weight	750*710*720 mm	
	70kg	

Agress1100 High Performance Liquid Chromatography System



Agress1100 HPLC System is a cost-effective product, and it is suitable for use in the production or manufacture which needed to strict cost control.

Characteristics:

- * Affordable
- * VFD display screen
- * Control mode: external/internal
- * Easy to use
- * Superior repeatability



P1100 High Pressure Constant Flow Pump:

Flow Rate	0.001-10.000 mL/min (Step: 0.001 mL/min)
Accuracy	≤+0.3%
Precision	≤0.1% RSD
Max Pressure	42 MPa (6000 psi)
Power	AC 220 V, 50 Hz
Dimension/Weight	420*260*160 mm (L* W* H*) /12 kg



D1100 UV-Visible Detector:

Linearity	1.8 AU
Wavelength Range	190~700 nm
Noise	≤ ± 1.0*10 ⁻⁵ AU
Drift	≤ 2.0*10 ⁻⁴ AU/h
Power	AC220V ± 10%, 50 Hz, 100 W
Dimensions/Weight	420*260*160 mm (L* W* H*) /12 kg



O1100 Column Oven:

Temperature range	Ambient + 5 °C~99 °C
Accuracy	± 0.1 °C
Precision	≤ 0.1 °C
Power	AC220 V ± 10%, 50 Hz, 150 W
Dimensions/Weight	120 * 65 *500 mm (L* W* H*) /8.5 kg

Elitapex HPLC Workstation

Characteristics:

- * Simple operation and convenient use;
- * Optimize the control protocol to make the communication between the workstation and the unit instrument module more smooth;
- * Stable real-time feedback of the status and parameters of each unit module.

Technical Parameters:

Model	Agress1100(Type I)	Agress1100(Type II)
Pump	P1100*1	P1100*2
Detector	D1100*1	
Gradient Mixer	/	TD-1-15*1
Solvent Bottle Tray	ST1100*1	
Sampler Injector	Rheodyne 7725i*1	
Column	Supersil ODS2 5µm ID4.6*200mm*1	
Workstation	Elitapex*1	
Valve Mounting Frame	VB1100*1	
System Kit	Agress1100*1	
Power Supply	AC220V±10%, 50Hz	
Optional Accessory	500ml Solvent bottle*2, Column, Column Oven	
Package Size(W*D*H)	500*360*300mm*1; 580*400*280mm*2	500*360*300mm*1; 580*400*280mm*3
Gross Weight	38kg	53kg

EClassical 3100 High Performance Liquid Chromatography System



EClassical 3100 System is perfected from classical HPLC systems manufactured by our company, the high quality has widely recognized by customer. It is suitable for users who are looking for the versatility and robustness. The excellent features ensure the reliability results and improve working efficiency.

Characteristics:

- * Comprehensive and flexible
Isocratic system, binary gradient system, quaternary gradient system is available. Detection capabilities include DAD, UV/Vis, FL, RI and ELSD.
- * Stable and reliable
Advanced USB chip and optoelectronic isolation technology ensuring stable communication.
- * Simple and safe
Powerful software makes it simple to control, capture, manage and analyze. Real-time pressure display, maximum and minimum pressure warning ensure the security.



P3100 High-Pressure Constant Flow Pump:



Flow Range	0.001~10.000 mL/min (step 0.001 mL/min)
Accuracy	±0.2%
Precision	≤0.06% RSD
Pressure Range	0-45 MPa
Power	AC 220 V±10%, 50 Hz/80 W
Dimensions/Weight	420*300*175 mm (L* W*H)/12 kg

P3130 Low-Pressure Quaternary Constant Flow Pump:

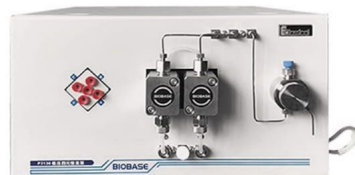

Flow Range	0.001~10.000 mL/min (step 0.001 mL/min)
Gradient Accuracy	±1%
Retention Time Repeatability	≤0.1%
Maximum Working Pressure	63 MPa
Communication Methods	UDP Network Communication
Mixed Volume	750µL
Power	AC 220 V±10%, 50 Hz/100 W
Dimensions/Weight	400*300*180 mm (L* W*H)/15 kg



UV3100 UV-Vis Detector:

Linear	2.0 AU
Wavelength Range	190~700 nm
Noise	±0.5*10 ⁻⁵ AU
Drift	≤1.0*10 ⁻⁴ AU/h
Cell	Analytical: Optical path 10 mm, 11µL Semi-prep scale: Optical path 2 mm, 6 µL
Power	AC 220V±10%, 50 Hz/100 W
Dimensions/Weight	420*300*175 mm (L*W*H) /16 kg



DAD3100 Diode Array Detector:

Linear	≥2.0 AU
Wavelength Range	190~800 nm
Noise	±1.0*10 ⁻⁵ AU
Drift	≤2.0*10 ⁻⁴ AU/h
Power	AC220 V±10%, 50 Hz/180 W
Dimensions/Weight	500*300*175 mm (L*W*H) /18 kg



O3100 Column Oven:

Temperature Range	Ambient + 5 °C~85 °C
Accuracy	±0.3 °C
Precision	±0.1 °C
Power	AC220 V±10%, 50 Hz/130 W
Dimensions /Weight	420*300*120 mm (L* W*H)/7 kg

Technical Parameters:

Model	EClassical 3100 (Type I)	EClassical 3100 (Type II)	EClassical 3100 (Type III)	EClassical 3100 (Type IV)
Pump	P3100*1	P3100*2	P3130*1(With mixer)	
Detector	UV3100*1			DAD3100 512*1
Gradient Mixer	/	TD-1-15*1	/	
Solvent Bottle Tray	TP3100*1			
Sampler Injector	Rheodyne 7725i*1			
Column	Supersil ODS2 5µm ID4.6*200mm*1			
Workstation	Kromstation*1			Kromstation+PDA
AD Adapter	/			AD adapter + startup kit
Valve Mounting Frame	ZJ-1*1		ZJ-4*1	
Degasser	/			DG3110*1
System Kit	EClassical 3100*1			
Power Supply	AC220V±10%, 50Hz			
Optional Accessory	500ml Solvent bottle*2, Column, Column Oven, S3100 Auto-sampler, Degasser		500ml Solvent bottle*4, Column, Column Oven, S3100 Auto-sampler	
Package Size (W*D*H)	600*440*380mm*2	600*440*380mm*3	600*440*380mm*2 320*190*230mm*1	600*440*380mm*2 320*190*230mm*1 500*360*100mm*1
Gross Weight	30kg	45kg	34kg	39kg

EClassical 3200 High Performance Liquid Chromatography System



The newly developed EClassical 3200 high performance liquid chromatography system meets the constantly upgraded regulatory requirements and redefines the appearance design of domestic liquid phase, perfects the automaticity, continuity and integrity of the analysis process, demonstrates the stability of laboratory results, and meets the feasibility

Feature:

- * Classic, inherited product reliability for more accurate and consistent results.
- * Professional, national standard technology leader, making more effective and applicable.
- * Efficient, perfectly superb compatibility makes more convenient and easier.

O3220 Column Oven:

Temperature range	Ambient + 5 °C~80 °C
Accuracy	±0.5 °C
Precision	≤0.1 °C
Power	AC220 V±10%, 50 Hz/130 W
Dimensions /Weight	435*137*450 mm (L* W*H)/11 kg

P3220 High-Pressure Constant Flow Pump:

Flow Range	0.001~10.000 mL/min (step 0.001 mL/min)
Accuracy	≤±0.2%
Precision	≤0.06% RSD
Pressure Range	0-70 MPa
Communication Methods	UDP Network Communication
Power	AC 220 V±10%, 50 Hz/300 W
Dimensions/Weight	450*350*185 mm (L* W*H)/18 kg

P3230 Low Pressure Quaternary Pump:

Flow Range	0.001~10.000 mL/min (step 0.001 mL/min)
Accuracy	≤±0.2% (1.00mL/min, H ₂ O, R.T 8.5MPa)
Stability	<0.06% (1.00m/min, H ₂ O, R.T, 8.5MPa)
Maximum Pressure	63MPa
Pulsation	≤0.1MPa(1.00m/min, H ₂ O, R.T, 8.5MPa)
Communication Methods	UDP Network Communication
Power	AC 220 V±10%, 50 Hz/150 W
Dimensions/Weight	440*380*180 mm (L* W*H)/18 kg

D3210 UV-Vis Detector:

Linearity	≥2.5 AU
Wavelength Range	190~800 nm
Wavelength Repeatability	±0.1nm
Wavelength Accuracy	±1.0nm
Noise	≤1.5*10 ⁻⁵ AU (Single wavelength) ≤5.0*10 ⁻⁵ AU (Double wavelength)
Drift	≤2.0*10 ⁻⁴ AU/h
Light Source	Deuterium Lamp, Tungsten Lamp
Optical Path	Dual beam optical path
Response Time	0.1~5s
Sampling Frequency	5Hz\10Hz\20Hz\50Hz; Double wavelength 1Hz
Cell	Optical path 10 mm; Proof pressure 1000psi
Communication Methods	UDP Network Communication
Power	AC 220 V±10%, 50/60 Hz/100 W
Dimensions/Weight	440*378*160 mm (L*W*H)/10 kg



Technical Parameters:

Model	EClassical 3200 (Type I)	EClassical 3200 (Type II)	EClassical 3200 (Type III)
Pump	P3220*1		P3230*1
Detector	D3210*1		
Solvent Switching Module	/	Solvent switching module (built in high pressure pump)*1	/
Solvent Bottle Tray	T3200*1		
Sampler Injector	Rheodyne 7725i*1		
Column	Supersil ODS2 5μm ID4.6*250mm*1		
Workstation	Kromstation*1		
Valve Mounting Frame	VB3200*1		
Multifunctional Mounting Frame	MB3200*1		
Column Mounting Frame	CB3200*1		
System Kit	EClassical 3200*1		
Power Supply	AC220V±10%, 50Hz		
Optional Accessory	Auto-sampler, Column, O3220Column Oven, D3270 Evaporative Light Scattering Detector, RI-201H Differential Refractive Index Detector, D3250 Fluorescence Detector Solvent bottle 1000ml *2	Auto-sampler, Column, O3220Column Oven, D3270 Evaporative Light Scattering Detector, RI-201H Differential Refractive Index Detector, D3250 Fluorescence Detector Solvent bottle 1000ml *4	
Package Size(W*D*H)	580*470*370mm*3	580*470*370mm*3	
Gross Weight	43kg	43kg	

iChrom 5100 High Performance Liquid Chromatography System

iChrom 5100 system can load variety of configurations, such as manual valve and automatic sampler, detectors including UV, DAD, LIFD, RI, ELSD, and widely used in food, medicine, environmental protection and scientific research.

Features:

- * High integrated SPI, I2C bus and ARM micro-controller technology Poston floating design makes more stable flow.
- * Intellectualized sequence analysis and batch processing functions bringing more convenience.
- * Automatic wavelength positioning and excellent wavelength accuracy.
- * Enable 21 CFR Part 11 compliance.



P5100 Series Pumps:

P5101 high pressure pump; P5102 high pressure binary pump; P5103 low pressure quaternary pump



Flow Range	0.001~10.000 mL/min (step 0.001 mL/min)
Accuracy	±0.2%
Precision	≤0.06% RSD
Pressure Range	0- 63 MPa
Power	AC 220V±10%, 50 Hz/100 W
Dimensions/Weight	540*400*160 mm (L*W*H)/25 kg

D5101 UV-VIS Detector:



Linearity	≥2.0 AU
Wavelength Range	190~800 nm
Noise	±0.25*10 ⁻⁵ AU
Drift	≤0.5*10 ⁻⁴ AU/h
Power	AC 220V±10%, 50 Hz/100 W
Dimensions/Weight	540*400*160 mm (L*W*H)/16 kg

D5115/5116 Diode Array Detector:



Linearity	≥2.0 AU
Wavelength Range	190~800 nm
Noise	±1.0*10 ⁻⁵ AU
Drift	≤2.0*10 ⁻⁴ AU/h
Power	AC 220V±10%, 50 Hz/100 W
Dimensions/Weight	540*400*160 mm (L*W*H)/16 kg

O5101 Column Oven:



Temperature range	Ambient + 5 °C~85°C
Accuracy	±0.1°C
Precision	≤0.1°C
Power	AC220 V±10%, 50 Hz/130 W
Dimensions/Weight	540*400*120 mm (L*W*H) / 15 kg

M5100 System Controller:

M5100 system controller integrates data communication hub, power distribution hub, solvent tray, and on-line degassing.

M5101 System controller for iChrom 5100

M5102 System controller for iChrom 5100 with binary on-line degassing

M5103 System controller for iChrom 5100 with quaternary on-line degassing use with P5103



On-line Degasser	2-4
Wetted Materials	PEEK, Teflon® AF
Power	AC 220V±10%, 50 Hz/30 W
Dimensions /Weight	540*400*120 mm (L*W*H)/10 kg

Technical Parameters:

Model	iChrom 5100 (Type I)	iChrom 5100 (Type II)	iChrom 5100 (Type III)	iChrom 5100 (Type IV)
Pump	P5101*1	P5102*1	P5103*1	
Detector	D5101*1			DAD5115 512 *1
System Controller	M5101*1		M5103*1	
Sampler Injector	Rheodyne 7725i*1			
Column	Supersil ODS2 5µm ID4.6*200mm *1			
Workstation	Kromstation*1			Kromstation+PDA
Valve Mounting Frame	VB5101 *1			
System Kit	iChrom 5100 *1			
Power Supply	AC220V±10%, 50Hz			
Optional Accessory	500ml Solvent bottle*2, Column, Column Oven, S5100 Auto-sampler, M5102 System controller (for iChrom 5100 (type II))		500ml Solvent bottle*4, Column, Column Oven, S5100 Auto-sampler	
Package Size(W*D*H)	700*570*350mm*2 700*570*310mm*1			
Gross Weight	75kg			

Gas Generator Hydrogen Generator



Introduction:

The hydrogen generator is to generate hydrogen by electrolyzing water through PEM or AWE electrolysis technology. It consists of water tank, electrolyzer, power supply, gas-water separator, drying pipe, pressure controller and other parts.

Application:

Hydrogen generator can be used as gas and carrier gas for GC (gas phase), reactive gas for ELCD (conductance detector), and reactive gas for ED (Atomic emission spectrometry detector).

Features:

- * Safe use, water shortage shutdown, overpressure shutdown.
- * Easy to operate, turn on the power to the standby state, panel start and stop button control start and stop.
- * The working status shows the flow, and the fault status indicates the fault information.
- * Automatic constant pressure.

Technical Parameters:

Model	BK-HYG-300P
Output Flow	0~300ml/min
Hydrogen Purity	99.999%
Output Pressure	4kg/cm ² (about 0.4Mpa)
Pressure Stability	<0.001MPa
Environment Temp	1~40°C
Relative Humidity	<85%
Consumption	150W
Power Supply	110V/220V, 50/60Hz
External Size	410*370*220mm
Package Size	460*430*270mm
Net Weight	10kg
Gross Weight	14kg

Features:

- * Fast hydrogen production: The hydrogen generator can produce hydrogen without preheating.
- * High safety: The volume of the internal gas path in the hydrogen generator is less than 150ml, and the hydrogen is produced immediately after use, eliminating the risk of hydrogen storage.
- * Low long-term use cost: just add pure water during the operation of the hydrogen generator, and the cost of consumables is low.
- * Green and environmental protection: The hydrogen generator uses electrolysis of water to produce hydrogen. During the hydrogen production process, only hydrogen and oxygen are produced, which has no pollution to the environment.
- * Easy to use: The hydrogen generator can be used continuously as a gas source, avoiding frequent replacement of gas cylinders.



Technical Parameters:

Model	BK-HYG-600P
Hydrogen Purity	≥99.999%
Rated Flow	600ml/min
Output Pressure	0-0.4MPa
Safety Valve Releases Pressure	0.5MPa±0.05MPa
Working Noise	≤55dB
External Size	430*220*380mm
Net Weight	11kg
Power Supply	AC220V/110V, 50Hz/60Hz
Packing Size	670*470*630mm
Gross Weight	20kg

Pure Water Hydrogen Generator



Laboratory Type

Features:

- * SPE technology. * No corrosion and pollution.
- * High purity hydrogen (99.999%)(for Laboratory type). * Suitable for all kinds of GC(Gas chromatography).
- * Stable output flow, safe and convenient to operate, various alarm devices (over pressure alarm, water shortage alarm, water accumulated alarm).
- * The electrolytic cell adopts imported ionic membrane, which has the characteristics of resistance, durability and long life.(for Breathing Type (plastic shell).
- * The output flow of electrical automatic control system is stable and the fluctuation is small. (for Breathing Type (plastic shell).

Technical Parameters:

Model	HGC-200	HGC-300	HGC-600
Type	Laboratory type	Laboratory type	Laboratory type
Output Flow(ml/min)	0~200	0~300	0~600
Output Pressure	0.4MPa/0.02~0.7MPa (under stable pressure)	0.4MPa/0.02~0.7MPa (under stable pressure)	0.4MPa/0.02~0.7MPa (under stable pressure)
Hydrogen Purity	>99.999%	>99.999%	>99.999%
Silicon tube	Yes	Yes	Yes
Pressure stability	<0.001Mpa		
Consumption	120W	150W	300W
Power Supply	AC 110V/ 220V±10%, 50/60Hz		
External Size (W*D*H)	350*220*380mm	350*220*380mm	350*220*380mm
Package Size (W*D*H)	500*370*540mm	500*370*540mm	500*370*540mm
Net Weight	11kg	11kg	13kg
Gross Weight	12kg	12kg	14kg

Nitrogen Generator



Features:

- * Improved double-cathode stainless steel electrolytic separation cell. Nitrogen production by electrolysis and oxygen exhaust are carried out simultaneously, and the electrolyte circulation is unimpeded.
- * The electrolysis separation cell has large electrolysis area, low cell temperature, large gas production, and higher nitrogen purity.
- * The unique anti-liquid return device ensures that the instrument will never return liquid.
- * Equipped with the function of voltage stabilization and automatic closing of the gas circuit after power failure.
- * Adopt advanced switching power supply to improve the efficiency of electrolysis and separation.
- * Small size and light weight, some products use oil-free compressors. (NG-300P/500P).
- * Need external air source(NG-300II/500II).

Technical Parameters:

Model	NG-300II	NG-500II	NG-300P	NG-500P
Output Flow(ml/min)	0-300 ml/min	0-500 ml/min	0-300 ml/min	0-500 ml/min
Output Pressure	0-0.5 Mpa(Factory setting 0.4Mpa)			
Purity	>99.997%			
Surrounding Requirement	Temperature 10~40°C			
	Humidity ≤85%			
Consumption	80W	120W	650W	750W
Power Supply	AC220V±10%, 50Hz±5%(Standard) AC110, 60Hz(Optional)			
Instrument Size(W*D*H)	320*220*370mm		400*300*640mm	
Package Size(W*D*H)	390*280*430mm		475*375*720mm	
Net Weight	15kg		40kg	
Gross Weight	17kg		42kg	

Hydrogen Generator



HG-300II

HG-500II

Features:

- * Easy to operate, safe and reliable, one-time add alkali, daily use only need to supplement distilled water. Turn on the power switch to produce hydrogen.
- * The air passage part is made of stainless steel pipe. Electrolytic polishing, ultrasonic cleaning. With over - pressure protection device, two - stage purification.
- * Unique anti-return device, to ensure that the instrument no liquid back phenomenon.
- * Cartridge type electrolytic tank, electrolytic materials imported special precious metals, effectively improve the electrolytic efficiency, constant cell temperature, promote the service life of the electrolytic tank greatly improved.
- * Stable output flow and automatic tracking. Purity does not decay, can be used continuously.

Technical Parameters:

Model	HG-300II	HG-500II
Output Flow(ml/min)	0-300 ml/min	0-500 ml/min
Output Pressure	0-0.5 Mpa(Factory setting 0.4Mpa)	
Purity	>99.999%	
Surrounding Requirement	Temperature: 10~40°C	
	Humidity: ≤85%	
Consumption	220W	
Power Supply	AC220V±10%, 50Hz±5%(Standard) AC110, 60Hz(Optional)	
Instrument Size(W*D*H)	320*180*370mm	
Package Size(W*D*H)	390*250*460mm	
Net Weight	10kg	
Gross Weight	14kg	

Nitrogen & Hydrogen & Air Generator



NHA-300G

NHA-300II

Features:

- * Compact structure, high integration, easy to use, saving laboratory space.
- * Stainless steel gas storage tank, safe and reliable, can replace laboratory cylinders.
- * Hydrogen part: automatic anti-return alkali, automatic flow tracking, three-stage filtration.
- * Nitrogen part: automatic anti-return alkali. Automatic flow tracking. Three-stage filtration.
- * Oil-free compressor, better air quality, heat insulation pad choose Dow, cylinder type electrolytic cell electrolytic area, long service life.(NHA-300G)
- * Air part: use oil-free compressor, stainless steel gas tank, two-stage voltage stabilization, three-stage filter, high precision, automatic drainage and perfect protection measures.

Technical Parameters:

Model		NHA-300G	NHA-300II
Output Flow(ml/min)	Nitrogen Hydrogen	0-300 ml/min	0-500 ml/min
Output Pressure	Nitrogen Hydrogen Air	0-0.5 Mpa(Factory setting 0.4Mpa)	
Purity	Nitrogen	> 99.997%	
	Hydrogen	> 99.999%	
Surrounding Requirement	Temperature	10~40°C	
	Humidity	≤85%,No large amount of dust and corrosive gas	
Consumption		850W	500W
Power Supply		AC220V±10%, 50Hz±5%(Standard) AC110V, 60Hz(Optional)	
Instrument Size(W*D*H)		300*455*665mm	
Package Size(W*D*H)		530*380*750mm	
Gross Weight		46kg	39kg

Oxygen Production System



Introduction:

Integrated medical molecular sieve oxygen production system, is a new type of equipment that extracts oxygen from air using molecular sieve as adsorbent and advanced pressure swing adsorption (PSA) technology.

Features:

- * Overall structure assembly, easy installation, unique technology to achieve zero pressure start.
- * Professional oxygen filter, improve filtration efficiency.
- * Precision gas mass flow controller, real-time measurement and control of oxygen flow.
- * 10-inch color human-computer interaction interface, automatic control, easy to use.

Technical Parameters:

Model	BSZY-3	BSZY-6	BSZY-10
Oxygen Supply Flow(m³/h)	3.0	6.0	10.0
Oxygen Concentrations	≥90%		
Oxygen Outlet Pressure	0.2~0.5MPa adjustable		
Consumption(kW)	9	13	25
Power Supply	AC380V, 50Hz; Three-phase AC 220V, 50Hz(Optional)		
Noise	≤85dB(A)		
Using Temp.	5~40°C		
Environmental Humidity	≤80%		
External Size(W*D*H)	1900*1380*1945mm	1900*1430*1945mm	2100*1530*2115mm
Package Size(W*D*H)	2070*1520*2100mm	2070*1570*2100mm	2270*1670*2270mm
Net/Gross Weight(kg)	960/1120	1030/1200	1300/1500

Pulse Oximeter



Instruction:

Finger-clamp pulse oximeter is an economical and affordable instrument that accurately detects pulse rate and blood oxygen saturation through fingers. It also displays a volume waveform chart to ensure accuracy. The unique PI index effectively reflects the pulsating blood flow.

The self-adjusting finger clip and one-button design are easy to operate.

The screen is adjustable in 5 levels of brightness, small in size, easy to carry, suitable for daily use, and can measure your health at any time.

Application:

It is suitable for families, clinics, oxygen bars, sports health care (used before and after exercise, not recommended for use during exercise), community medical care, etc. It is suitable for patients aged 15-60. This product is not suitable for continuous monitoring of patients.

Features:

- * OLED display, high brightness, wide viewing angle, clearer display.
- * Adjustable display direction, 360 degree direction display.
- * Small size, light weight, easy to carry.
- * Automatic shutdown in 8 seconds without finger
- * Low power consumption, two AAA batteries can be used for 50 hours.
- * Anytime, anywhere, non-invasive and painless, easy to operation.

Technical Parameters:

Model	PO-40A	PO-50B
SpO ₂ Range	70%~99%	35%~100%
SpO ₂ Accuracy	±2%	±1% (90%~99%); ±2% (70%~89%)
Pulse Rate(PR)Range	30bpm~250bpm	25bpm~250bpm
Pulse Rate(PR)Accuracy	±1bpm	
Display	OLED	
Display Refresh Frequency	1s	
Calculation Time	8s	
Fuse	466 Series, 0.5A6.3V	
Power Supply	DC3V (2*AAA Battery)	
External Size(W*D*H) mm	57*31*30	63*37*32
Package Size(W*D*H) mm	89*60*40	80*65*48
Gross Weight(g)	44 (Without battery)	54 (Without battery)

Jacketed Glass Reactor

Application:

Jacketed glass reactors are designed for synthetic reaction of different types of materials in a controlled temperature and vacuum environment. Each reactor features adjustable stirring speeds and a constant pressure feeding funnel that allows you to add material to the vessel at a uniform and controlled speed. The built-in condenser makes it possible to recover some materials, also at a controlled rate of speed.



Features:

- * GG17 high borosilicate glass, with good chemical and physical properties.
- * The evaporation and back-flow of reaction material can be controlled.
- * The heat of reaction could be taken away quickly through water, cycling in the jacketed glass.
- * The design of large bottle mouth, easier to clean.
- * It can be used as a distillation syntheses device.
- * The sealing performance is 0.098 Mpa.
- * LCD display, easier and more convenient to measure temperature.

Optional Equipment:

- * Circulating water vacuum pump: (JGR-1L~5L, recommend mode SHZ-DIII, JGR-10L~100L, recommend model SHZ-95B)
- * Refrigerated Circulator
- * Circulating water/oil bath

Technical Parameters:

Model	JGR-1L	JGR-2L	JGR-3L	JGR-5L	JGR-10L	JGR-20L	JGR-30L	JGR-50L	JGR-100L
Reaction Flask Capacity	1L	2L	3L	5L	10L	20L	30L	50L	100L
Stirring Power	60W				120W			180W	
Stirring Speed	0~600rpm(Max.1300 customized)								
Stirring Shaft Diameter	12mm								15mm
Motor Torque(g/cm)	2000	2400	4800		1000	1200	1500		3000
Power Supply	AC110/220V, 50/60Hz								
Package Size (W*D*H)	1260*430*460mm		1300*580	1310*600	1230*610	1320*630	1650*660*780mm		1840*720
			*540mm	*540mm	*750mm	*750mm			*910mm
Gross Weight	40kg	46kg	53kg	56kg	81kg	85kg	90kg	100kg	151kg

High Pressure Reactor



Application:

The autoclave is a stirring device for reacting gas-liquid, liquid-liquid, liquid-solid or gas-liquid-solid materials. It can fully stir and react various chemical materials under higher pressure, vacuum and temperature. It is a non-leakage reaction equipment for vulcanization and hydrogenation in petroleum, chemical, organic synthesis, polymer material polymerization, food and other processes.

Features:

- * Real-time monitoring of reaction pressure in the kettle.
- * High power agitator motor, strong and stable performance.
- * Using static sealing structure, the stirrer and the motor drive are connected by a magnetic coupling.
- * The medium and mixing parts are completely sealed to work.

Technical Parameters:

Model	HPR-0.1L	HPR-0.25L	HPR-0.5L	HPR-1L	HPR-2L	HPR-3L	HPR-5L	HPR-10L	HPR-20L	HPR-50L	HPR-100L
Capacity(L)	0.1	0.25	0.5	1	2	3	5	10	20	50	100
Pressure(Mpa)	22			10			6				
Temp(°C)	350			300							
Stirring Speed(r/min)	50-1000			50-600							
Material	SS304/SS316/Hastelloy alloy										
Heating Power(Kw)	0.1	0.8	1.5	2	2.5	4	7	10	12	14	
Power Supply	220V, 50/60Hz										
Package Size(mm)	670*470*140			720*420	510*740	770*520	840*590	870*620	920*670	980*800	990*840
Gross Weight(Kg)	100			101	150	170	196	218	280	480	680

High Temperature Thermostatic Circulating Oil/Water Bath



Features:

- * The structure is compact and reasonable, the stainless steel inner tank and the outer shell are made of high-quality steel plate electrostatic spraying;
- * Easy to use and simple to operate;
- * Accurate temperature control, controllable output flow, energy saving;
- * The outer circulation interface adopts high-quality copper material, which is anti-corrosion and corrosion-resistant and durable.

Technical Parameters:

Model	GY-5L	GY-10L	GY-20L	GY-30L	GY-50L	GY-100L
Liquid Storage Volume(L)	5	10	20	30	50	100
No-load Max Temperature(°C)	200					
Heating Power(kw)	2.8	2.8	1.5	2	2.8	3
Pressure	1.45MPa					
Cycle Way	Sealed magnetic pump cycles					
Flow Rate(L/min)	15-20		20-25			
Temperature Control Range(°C)	Water Bath: RT-100; Oil Bath: RT-250					
Temperature Error	≤2.50%					
HTF Viscosity(c°Cst)	Below 500					
Optional Parts	Explosion-proof motor and electricals					
No. of Heating Tube(pc)	1		2		3	
Power Supply	220V 50/60Hz, single phase, air switch				380V 50/60Hz, three phase, air switch	
Packing Size(mm)	590*490*800	590*490*800	590*490*880	640*540*870	700*600*890	750*650*1060
Gross Weight(kg)	35	40	43	47	55	80

Jar Tester

Application:

It's a testing instrument used to carry out the jar test during procedure of water treatment. It is used to simulate the process of adding agent, reaction, coagulation and settling which happen during the procedure of water treatment (including purification of drinking water and sewage treatment), widely used in scientific research, water supply plant and sewage treatment plant, colleges and universities, water treatment agent manufacturer etc.



BJT-4



BJT-6

Features:

- * LCD display
- * Synchro run, independent run

- * Store 12 groups of programs
- * Automatic calculating G & GT value
- * Automatic agent dosing and elevating

Technical Parameters:

Model	BJT-4(Portable)	BJT-6(Desktop)
Beakers	4pcs	6pcs
Acrylic Beaker	Round, 0.6L Φ95*130mm	Round, 1.0L Φ110*180mm
		Square optional, 1.5L 110*110*170mm
Speed Range	10~1000rpm, stepless speed regulation	
Speed Accuracy	±0.5%	
Speed Gradient(G value)	10~1000/s. Just for round beaker	
Running Time	Each step: 0~99min99s, 10 steps each program	
Measurement Temp. Range	0~50°C	
Measurement Temp. Accuracy	±1°C	
Consumption	80W	180W
Power Supply	AC220V±10%, 50Hz	
External Size(W*D*H)	550*390*210mm	1080*350*400mm
Package Size(W*D*H)	610*450*270mm	950*470*500mm
Gross Weight	11kg	33kg

Automobile Exhaust Analyzer

Applications:

Used to measure vehicle emissions of gas concentration.



BK-EA201



BK-EA301



BK-EA401



BK-EA501

Features:

- * With built-in printer
- * With a high-brightness digital display
- * Automatic zero, linear automatic data processing, auto-alarm when the gas line blocking

Technical Parameters:

Model	BK-EA201	BK-EA301	BK-EA401	BK-EA501
Measuring Range	HC: 0~10000*10 ⁻⁶ (ppm)vol CO: 0~10*10 ⁻² (%)vol	HC: 0~10000*10 ⁻⁶ (ppm)vol CO: 0~10*10 ⁻² (%)vol NO _x : 0~5000*10 ⁻⁶ (ppm)vol	HC: 0~10000*10 ⁻⁶ (ppm)vol CO: 0~10*10 ⁻² (%)vol CO ₂ : 0~20*10 ⁻² (%)vol O ₂ : 0~25*10 ⁻² (%)vol λ: 0.50~3.00 CO _{cor} : 0~10*10 ⁻² (%)vol	HC: 0~10000*10 ⁻⁶ (ppm)vol CO: 0~10*10 ⁻² (%)vol CO ₂ : 0~20*10 ⁻² (%)vol O ₂ : 0~25*10 ⁻² (%)vol NO _x : 0~5000*10 ⁻⁶ (ppm)vol λ: 0.50~3.00 CO _{cor} : 0~10*10 ⁻² (%)vol
Indicating Error	HC±12*10 ⁻⁶ (ppm)vol CO±0.06*10 ⁻² (%)vol	HC±12*10 ⁻⁶ (ppm)vol CO±0.06*10 ⁻² (%)vol NO _x ±25*10 ⁻⁶ (ppm)vol	HC±12*10 ⁻⁶ (ppm)vol CO±0.06*10 ⁻² (%)vol CO ₂ ±0.5*10 ⁻² (%)vol O ₂ ±0.1*10 ⁻² (%)vol	HC±12*10 ⁻⁶ (ppm)vol CO±0.06*10 ⁻² (%)vol CO ₂ ±0.5*10 ⁻² (%)vol O ₂ ±0.1*10 ⁻² (%)vol NO _x ±25*10 ⁻⁶ (ppm)vol
Stability	Moment drifts±3%			
Repeatability	≤±2%			
Response Time	95% response is not more than 10 seconds			
Preheating Time	8min (preheating 3min emergency detection)			
Power Supply	AC110~240V±10%, 50/60Hz; Optional DV12V			
Package Size(W*D*H)	620*435*295mm			
Gross Weight	12.5kg			

Refractometer Portable Digital Refractometers



PDR-series



PDR-F series

Features:

- * Wide choice-over 20 models available
- * Automatic temperature compensation
- * Automatic power management
- * With IP65 verification of waterproof and dustproof (only PDR-F series)

Technical Parameters:

Model	Scale	Range	Min. Reading	Accuracy	Temp. Range	Temp. Precision	Power Supply	Packing Size (W*D*H)mm	G.W. (kg)
PDR-35	Brix (%)	0~35%	0.1	±0.2	0°C~40°C (32°F~104°F)	±0.5°C(1°F)	2 x AAA (1.5V)	165*95*60	0.35
	Refractiv Index	1.3330~1.3900	0.0001	±0.0003					
PDR-45	Brix (%)	0~45%	0.1	±0.2					
	Refractiv Index	1.3330~1.4098	0.0001	±0.0003					
PDR-85	Brix (%)	0~85%	0.1	±0.5					
	Refractiv Index	1.3330~1.5100	0.0001	±0.0005					
PDR-92	Brix (%)	58~92%	0.1	±0.2					
	Refractiv Index	1.4370~1.5233	0.0001	±0.0003					
PDR- HN1	Brix (%)	58~92%	0.1	±0.2					
	° B, e	38~43	0.1	±0.1					
	Water (IHC2002)	13~25	0.1	±0.1					
	Refractiv Index	1.4370~1.5233	0.0001	±0.0003					
PDR-HN2	Brix (%)	58~92%	0.1	±0.2					
	° B, e	38~43	0.1	±0.1					
	Water (IHC2002)	17~27	0.1	±0.1					
PDR-A1	Salinity	0~28%	0.1	±0.2					
	Refractiv Index	1.3330~1.3900	0.0001	±0.0003					
PDR-S1	Brix (%)	0~35%	0.1	±0.2					
	Salinity	0~28%	0.1	±0.2					
	Refractiv Index	1.3330~1.3900	0.0001	±0.0003					

Technical Parameters:

Model	Scale	Range	Min. Reading	Accuracy	Temp. Range	Temp. Precision	Power Supply	Packing Size (W*D*H)mm	G.W. (kg)
PDR-R1	SERUM P. (g/dl)	1.000~1.050	0.001	±0.001	0°C~40°C (32°F~104°F)	±0.5°C(1°F)	2 x AAA (1.5V)	165*95*60	0.35
	URINE SP.G	0~12g/dl	0.1	±0.1					
	Refractiv Index	1.3330~1.3900	0.0001	±0.0003					
PDR-R2	SERUM P. (g/dl)	0~14g/dl	0.1	±0.1					
	URINE SP.G (dog)	1.000~1.060	0.001	±0.001					
	Refractiv Index	1.3330~1.3900	0.0001	±0.0003					
PDR-R3	SERUM P. (g/dl)	0~14g/dl	0.1	±0.1					
	URINE SP.G (cat)	1.000~1.060	0.001	±0.001					
	Refractiv Index	1.3330~1.3900	0.0001	±0.0003					
PDR-L1	Alcohol	0~60%v/v	0.1	±0.3					
PDR-L2	Alcohol	0~60%w/w	0.1	±0.5					
PDR-L5	Methanol	0~60%w/w	0.1	±0.5					
PDR- FWN1	Brix (%)	0~35%	0.1	±0.2					
	VOL AP (%)	0~22%	0.1	±0.2					
	Oe (Germany)	30~150	1	±1					
	KMW	0~25	0.1	±0.2					
PDR-FWN2	Brix (%)	0~35%	0.1	±0.2					
	VOL AP (%)	0~22%	0.1	±0.2					
	Oe (Germany)	30~150	1	±1					
PDR-FWN3	Brix (%)	0~35%	0.1	±0.2					
	VOL AP (%)	0~22%	0.1	±0.2					
	Oe (Switzerland)	0~150	1	±1					
PDR-FK1	Brix (%)	0~35%	0.1	±0.2					
	VOL AP (%)	0~22%	0.1	±0.2					
	KMW	0~25	0.1	±0.2					
PDR-FK1	Soybean milk concentration	0~35%	0.1	±0.3					
	Glycol	32~50°F	0.1 °F	±1 °F					
	Propanediol	32~50°F	0.1 °F	±1 °F					
PDR-FC1	Battery fluid	1.00~1.50sg	0.01 sg	±0.01 sg					
	Glass water	32~40°F	0.1 °F	±1 °F					
	Glycol	0~50°C	0.1°C	±1 °C					
PDR-FC2	Propanediol	0~50°C	0.1 °C	±1 °C					
	Battery fluid	1.00~1.50sg	0.01 sg	±0.01 sg					
	Glass water	0~40°C	0.1 °C	±1 °C					

Portable Digital Refractometers



PDR-series



PDR-F series

Technical Parameters:

Model	Scale	Range	Min. reading	Accuracy	Temp. Range	Temp. Precision	Power Supply	Packing Size(W*D*H) mm	G.W. (kg)
PDR-WN1	MASS S/W(%)	0~35%	0.1	±0.2	0°C~40°C (32°F-104°F)	±0.5°C(1°F)	2 x AAA (1.5V)	165*95*60	0.35
	VOL AP(%)	0~22%	0.1	±0.1					
	Oe(Germany)	0~150	1	±1					
	KMW	0~25	0.1	±0.1					
PDR-WN2	MASS S/W(%)	0~35%	0.1	±0.2					
	VOL AP(%)	0~22%	0.1	±0.1					
	Oe(Germany)	30~150	1	±1					
	KMW	0~25	0.1	±0.1					
PDR-WN3	MASS S/W(%)	0~35%	0.1	±0.2					
	VOL AP(%)	0~22%	0.1	±0.1					
	Oe(Germany)	0~150	1	±1					
	KMW	0~25	0.1	±0.1					
PDR-K1	Soybean milk concentration	0~35%	0.1	±0.3					
PDR-C1	Glycol	32~-50°F	0.1 °F	±1 °F					
	Propanediol	32~-50°F	0.1 °F	±1 °F					
	Battery fluid	1.00~1.50sg	0.01 sg	± 0.01 sg					
	Clearance	0~-40°F	0.1 °F	±1 °F					
PDR-C2	Glycol	0~-50°C	0.1°C	±1 °C					
	Propanediol	0~-50°C	0.1 °C	±1 °C					
	Battery fluid	1.00~1.50sg	0.01 sg	± 0.01 sg					
	Clearance	0~-40°C	0.1°C	±1 °C					

Portable Refractometer

Application:

Low Range: fruit juice, tomato juice, cola and most kinds of beverage
Middle Range: concentrated fruit juice, canned food, sugar solution inclusions, sauce, ketch up, seasoning and many kinds of industry fluids
High Range: liquid sugar, honey etc.



They can be used for industry fluid testing, such as for vegetable oils, industry, and many other chemical liquids or laboratory use fluids

Technical Parameters:

	Model	Range	Minimum Scale	Package Size(W*D*H)	Gross Weight
Brix	BK-PR5	0~5%	0.1%	200*95*80mm	0.35kg
	BK-PR10	0~10%	0.1%		
	BK-PR18	0~18%	0.1%		
	BK-PR20	0~20%	0.1%		
	BK-PR32	0~32%	0.2%		
	BK-PR50	0~50%	0.5%		
	BK-PR60	0~60%	0.5%		
	BK-PR62	28~62%	0.2%		
	BK-PR82	45~82%	0.5%		
	BK-PR92	58~92%	0.2%		
	BK-PR80	0~80%(1 ranges)	0.5%		
	BK-PR90	0~90%(1 ranges)	0.5%		
Honey	BK-PRN3	58~92% Brix	0.5% Brix		
		38~43 oBe'	0.5 oBe'		
		12~27% Water	1% Water		
Salinity	BK-PRA1	0~100‰	1‰		
		1.000~1.070	0.005		
	BK-PRA2	0~28%	0.2%		
	BK-PRA3	0~35%	0.5%		
	BK-PRA4	0~40 PPT	1‰		
	BK-PRS1	0~100‰ Salinity	1‰		
		1.000~1.070	0.005		
	BK-PRS2	0~10% Brix	0.1%		
		0~28% Salinity	0.2%		
			0~32% Brix	0.2%	

ABBE Digital Refractometer

Features for BK-RZT:

- * Full automatic measuring
- * Touch Screen
- * LCD temperature display, automatic correction and saving the data
- * Standard RS232 and USB interface



BK-RZT

Features for BK-R2S:

- * Hard glass prism
- * Standard RS232 interface
- * Measure the Brix of sugar solution
- * Visual aim and LCD display
- * Automatic correcting of the effect of temperature on the Brix
- * Measuring refractive index nD of transparent or translucent liquid and solid substances.



BK-R2S

Technical Parameters:

Model	BK-RZT	BK-R2S
Measuring Range	1.30000~1.70000nD Brix: 0-100%	1.3000~1.7000nD Brix: 0-100%
Measuring Resolution	±0.00001nD Brix: ±0.01%	±0.0001nD
Measuring Accuracy	±0.0002nD Brix: ±0.1%	±0.0002nD Brix: ±0.1%
Test Mode	8	/
Temperature Range	10~60°C	0~50°C
Temperature Resolution	0.1°C	
Temperature Accuracy	0.5°C	
Interface	RS232, USB	RS232
Display	7" LCD touch screen	LCD
Prism	Hard glass	
Power Supply	AC110/220V±10%, 50/60Hz	
External Size(W*D*H)	340*200*110mm	210*110*310mm
Package Size(W*D*H)	500*330*220mm	370*240*470mm
Gross Weight	9kg	12kg

Automatic Digital Refractometer



Features:

- * Multiple measurement modes: refractive index of spice and plant oil, F42 and F55 fructose syrup, concentration of glucose and sucrose, solid content, water content of honey, nD20, etc.
- * It meets graded management, provides scientific and user-friendly operation.
- * Fast measurement, only needs a small amount of samples.
- * Accurate detection and thermostatic control.
- * Prism is made of sapphire.

Technical Parameters:

Model	BK-R756
Measuring Range	nD: 1.30000~1.70000 Brix: 0~100%
Measuring Accuracy	Refractive index nD: ±0.0002 Brix: ±0.1%
Measuring Resolution	Refractive index nD: ±0.00001 Brix: ±0.01%
Temperature	Temperature display range : 0~100°C
Audit Trail	Optional(FDA)
Thermostatical Control Range	5~85°C
Temperature Control Accuracy	±0.02°C
Temperature Control Mode	Peltier (Built-in)
Interface	USB/Keyboard/Mouse/Universal Printer/ Ethernet/Optional:WLAN
Display	8 inch color touch screen
Data Storage	16G
Prism	Artificial sapphire
Power Supply	100V~240V, 50/60Hz, 150W
Gross Weight	5kg
Package Size	570*460*300mm

Polarimeter

Automatic Polarimeter



BK-P1/2

Features:

- * LCD Display
- * Photoelectric test and microcomputer control.
- * Preheating is not needed. (Only for BK-P1 and BK-P2 Model).
- * Dark-colored sample can be measure. (Only for BK-P1 and BK-P2 Model).
- * Automatic repetition-measurement for 6 times, and calculation of average value and means square root.
- * Sample chamber adopts constant temperature designing in order to reduce the temperature heating influence.

Technical Parameters:

Model	BK-P1	BK-P2
Light Source	LED lamp	
Measuring range	$\pm 45^\circ$ (optical rotation) / $\pm 120^\circ$ Z(sugar)	
Wavelength	589nm	
Readable Accuracy	0.001°(optical rotation)	
Measuring Accuracy	$\pm 0.01^\circ$ ($-15^\circ \leq$ optical rotation $\leq +15^\circ$) $\pm 0.02^\circ$ (optical rotation $< -15^\circ$ or optical rotation $> +15^\circ$)	
Repeatability	0.002°(optical rotation)	
Sample Transmittance	1%	
Temperature Control Range	/	15~30°C
Temperature Accuracy	$\pm 0.5^\circ\text{C}$	
Test Mode	Optical rotation, specific rotation, concentration, sugar degree	
Test Tube	200mm, 100mm	200mm, 100mm, 100mm (Constant Temperature tube)
Interface	USB&RS232	
Power Supply	AC110/220V+10%, 50/60Hz	
External Size(W*D*H)	690*370*280mm	
Package Size(W*D*H)	820*500*510mm	
Gross Weight	43kg	



BK-P3

Introduction:

Polarimeter is an instrument used to determine the rotation of a substance, and its working principle is based on the rotation of polarized light. By measuring the rotation angle of the sample to the polarized light, the concentration, content and purity of the substance can be analyzed and determined. Natural light through the polarizing mirror to produce plane polarized light, when the tube is filled with optical substances, polarized light through the material solution, the angle of polarized light will rotate to the left or right a certain angle. In order for the polarized light rotated at a certain angle to pass through the polarizer grating, the polarizer must be rotated at a certain angle so that the brightness can be seen at the eyepiece. This angle of rotation is the rotation of the solution of the substance to be measured.

Features:

- * LCD Display
- * Photoelectric test and microcomputer control.
- * Automatic repetition-measurement for 6 times, and calculation of average value and means square root.
- * Sample chamber adopts constant temperature designing in order to reduce the temperature heating influence.

Technical Parameters:

Model	BK-P3
Light Source	LED lamp
Measuring range	$\pm 45^\circ$ (optical rotation) / $\pm 120^\circ$ Z(sugar)
Wavelength	589nm
Readable Accuracy	0.001°(optical rotation)
Measuring Accuracy	$\pm(0.01 + \text{measurement value} \times 0.05\%)^\circ$ (optical rotation)
Repeatability	$\leq 0.003^\circ$ (optical rotation)
Test Mode	Optical rotation, specific rotation, concentration, sugar degree
Test Tube	200mm, 100mm
Interface	USB
Power Supply	AC110/220V+10%, 50/60Hz
External Size(W*D*H)	570*350*280mm
Package Size(W*D*H)	730*480*470mm
Gross Weight	36kg

Automatic Polarimeter



Introduction:

Polarimeter is an instrument for measuring the optical rotation of some substance. Through the measurement of optical rotation, it can analyze and determine the specific rotation, international sugar degree, concentration and purity of the substance, which is widely used in medicine, petroleum, food, chemical industry, flavor, fragrance, sugar and other industries as well as related universities and research institutes.

Features:

- * It can determine optical rotation, specific rotation, concentration, sugar degree.
- * LED cold light source instead of traditional sodium lamp and halogen tungsten lamp.
- * The measuring range is upgraded to $\pm 89^\circ$ (Optical rotation), which improves the limitation of measuring samples.
- * Fully automated systematic control, easy to operate.
- * Wide color touch screen and innovative WINDOWS software interface make control and data reading more convenient, to meet the use of high-end users.

Technical Parameters:

Model	BK-P210	
Light Source	LED cold light source + high precision interference filter	
Wavelength	589.3nm	
Measurement Method	Single, multiple, continuous measurement methods	
Measurement Range	Optical Rotation $\pm 89.99^\circ$, sugar degree $\pm 257^\circ$	
Optical Rotation	Least Count	0.001°
	Accuracy	$\pm 0.004^\circ$
	Repeatability	0.002°
Temperature	Temp. Range	0-100°C
	Temp. Resolution	0.1°C
	Temp. Accuracy	$\pm 0.1^\circ\text{C}$
Display	7 inch TFT touch color screen	
Standard Test Tube	200mm, 100mm (Regular)	
Optional	Test tube, printer	
Transmittance	0.01%	
Data Storage	1000 groups	
File Export	PDF and Excel	
Interface	USB, RS232	
Power Supply	220V \pm 22V, 50Hz \pm 1Hz	
Power	250W	
Net Weight	21.4kg	
Gross Weight	30kg	
Package Size(L*W*H)	820*475*465mm	

Automatic Digital Polarimeter



Introduction:

Polarimeter is an instrument for measuring the optical rotation of some substance. Through the measurement of optical rotation, it can analyze and determine the specific rotation, international sugar degree, concentration and purity of the substance, which is widely used in medicine, petroleum, food, chemical industry, flavor, fragrance, sugar and other industries as well as related universities and research institutes.

Features:

- * Built-in Peltier temperature control to improve accuracy and stability.
- * It can determine optical rotation, specific rotation, concentration, sugar degree.
- * LED cold light source instead of traditional sodium lamp and halogen tungsten lamp.
- * Multi-level rights management, rights can be freely configured.
- * 8 inch touch color screen, humanized operation interface.
- * It meets 21 CFR requirements (electronic signature, data traceability, audit trail, data tamper prevention and other functions).
- * Fully comply with GLP, GMP certification standards.

Technical Parameters:

Model	BK-P610	
Light Source	LED cold light source + high precision interference filter	
Wavelength	589.3nm	
Measurement Method	Single, multiple, continuous measurement methods	
Measurement Range	Optical Rotation $\pm 90^\circ$, sugar degree $\pm 259^\circ$	
Optical Rotation	Least Count	0.001°
	Accuracy	$\pm 0.004^\circ$
	Repeatability	0.002°
Temperature	Temp. Range	10°C-55°C (Peltier)
	Temp. Resolution	0.1°C
	Temp. Accuracy	$\pm 0.1^\circ\text{C}$
Display	8 inch TFT touch color screen	
Standard Test Tube	200mm, 100mm (Regular), 100mm (Temp. control)	
Optional	Test tube, printer	
Transmittance	0.01%	
Data Storage	32G	
File Export	PDF and Excel	
Interface	USB, RS232, VGA, Ethernet	
Power Supply	220V \pm 22V, 50Hz \pm 1Hz	
Power	250W	
Net Weight	21.4kg	
Gross Weight	30kg	
Package Size(L*W*H)	820*475*465mm	

BK-P2S Digital Automatic Polarimeter

BK-P2B Automatic Polarimeter



Features:

- * LCD Display
- * Storage of three times results and calculation of average values
- * Dark-colored sample can be measured
- * Photoelectric test and automatic servomechanism control

Technical Parameters:

Model	BK-P2S	BK-P2B
Light Source	LED lamp	
Measuring Range	$\pm 45^\circ$ (optical rotation) / $\pm 120^\circ Z$ (sugar)	$\pm 45^\circ$ (optical rotation)
Wavelength	589nm	
Readable Accuracy	0.001 $^\circ$ (optical rotation)0.01 $^\circ Z$ (sugar)	0.002 $^\circ$ (optical rotation)
Measuring Accuracy	$\pm(0.01+\text{measurement value} \times 0.05\%)^\circ$ (optical rotation) $\pm(0.03+\text{measurement value} \times 0.05\%)^\circ Z$ (sugar)	$\pm(0.01+\text{measurement value} \times 0.05\%)^\circ$
Repeatability	$\leq 0.002^\circ$ (optical rotation)	$\leq 0.01^\circ$ (optical rotation)
Test Mode	Optical rotation, sugar degree	Optical rotation
Test Tube	200mm, 100mm	
Sample Transmittance	> 1%	> 10%
Interface	RS232	
Power Supply	AC110/220V $\pm 10\%$, 50/60Hz	
External Size(W*D*H)	570*350*280mm	
Package Size(W*D*H)	730*480*470mm	
Gross Weight	36kg	

Disc Polarimeter



Features:

- * Visual aim
- * Manual measure
- * Easy to operate

Technical Parameters:

Model	BK-P4	BK-P4L
Light Source	Sodium lamp	LED
Wavelength	589.44nm	
Measuring Range	$-180^\circ \sim +180^\circ$	
Division Value	1 $^\circ$	
Venire Readable Accuracy	0.05 $^\circ$	
Magnifying Factor of the Magnifying Glass	4 X	
Test Tube	200mm, 100mm	
Power Supply	AC110/220V $\pm 10\%$, 50/60Hz	
External Size(W*D*H)	440*110*230mm	
Package Size(W*D*H)	600*220*400mm	
Gross Weight	7.6kg	

Optional Polarimeter Accessories

* Micro Tube

With sample loading capacity less than 0.8ml and length of 50mm, suitable for BK-P2S, BK-P2B, BK-P1, BK-P2, BK-P3, BK-P4 polarimeter.

* Thermostatic Tube

Dedicated to BK-P2 for the length of about 100mm, the sample loading is 2.5ml. And the non-corrosive type is optional to purchase.

* Standard Quartz Tube

The only calibration equipment for standard polarimeter and optical Brix; with stable performance, less influence by the environment, and easy-to-use features, The loading of quartz tube includes $\pm 1^\circ$, $\pm 5^\circ$, $\pm 7^\circ$, $\pm 34^\circ$ and $\pm 68^\circ$, for customer to choose accordingly.

Suitable for BK-P2S, BK-P2B, BK-P1, BK-P2, BK-P3, BK-P4 polarimeter.



Flash Point Tester

Open-Cup Flash Point Tester

Application:

It is applicable to all petroleum products with flash points above 79°C and below 400°C except fuel oils.

Features:

BK-FP3536:

- * It adopts special heating furnace to ensure the safety of test.
- * The heating power is continuously adjustable. It can meet requirements of test.
- * The instrument is fully self-contained complete. The operator can do determination as long as connecting with coal gas or other civil gas.
- * With fast cooling function, it can improve test efficiency.

BK-FP3536D:

- * 8-inch IPS high-definition capacitive screen, the test data and parameters are displayed by curve in real time
- * Automatic measurement of atmospheric pressure, automatic correction of flash point value.
- * Equipped with Bluetooth interface. The user can query test data anytime.
- * Electronic ignition, gas flame.
- * Remote automatic upgrade to obtain the latest version, remote prediction, abnormal early warning, comprehensive evaluation and maintenance of instrument operation status.



BK-FP3536



BK-FP3536D

Technical Parameters:

Model	BK-FP3536	BK-FP3536D
Thermometer	-6°C~400°C. It is the same as thermometer ASTM 11C	
Ambient Temperature	15°C~35°C	
Relative Humidity	≤85%	
Consumption	≤650W	≤750W
Test Flame Applicator	It applies the test flash automatically.	
Heating Device	Furnace heating, no naked fire, explosion prevented. The power is adjustable from 0W to 600W	1. Initial heating: (14~17) °C/min 2. It is (5-6) °C/min after reaching the preset flash point 20 °C
Igniting Device	(1) Ignition source: coal gas(or civil gas) (2) Flame diameter is 3.2mm~4.8mm	Electric ignition Diameter of igniter: 0.7mm~0.8mm
Flash Point Determination	\	Range: Ambient to 400°C Accuracy: 0.1°C
Power Supply	AC220V±10%, 50Hz	
Dimension(W*D*H)	350*290*350mm	510*320*330mm
Package Size(W*D*H)	650*450*420mm	690*500*610mm
Gross Weight	20kg	35kg

Closed-Cup Flash Point Tester

Application:

It is used to make determination of the closed cup flash point of the petroleum products.

Features:

BK-FP261:

- * The heating power is adjustable and shown visually by voltmeter.
- * The structure is designed small and exquisite with stainless-steel table board.

BK-FP261D:

- * 8-inch IPS high-definition capacitive screen, the test data and parameters are displayed by curve in real time.
- * Automatic measurement of atmospheric pressure, automatic correction of flash point value.
- * Equipped with Bluetooth interface. The user can query test data anytime.
- * Temperature rise, cover opening, ignition, detection and printing data are completed automatically, and the test arm rises and falls automatically.
- * Remote automatic upgrade to obtain the latest version, remote prediction, abnormal early warning, comprehensive evaluation and maintenance of instrument operation status.
- * Electronic ignition, gas flame, automatic air cooling at the end of the test.

Technical Parameters:

Model	BK-FP261	BK-FP261D
Ambient Temperature	15~35°C	
Relative Humidity	≤85%	
Flash Point Determination	Mercury-in-glass thermometer. Specifications are as below: Scale -5°C~110°C, division 0.5°C Scale 20°C~150°C, division 1°C Scale 90°C~370°C, division 2°C	Range: Ambient to 230°C Repeatability: ≤3°C Reproducibility: ≤4°C Accuracy: 0.1°C
Oil Cup	Inner diameter: 50.7mm~50.8mm. Depth: 55.7mm~56.0mm The scribed line depth of capacity of testing oil: 33.9mm~34.3mm. Capacity of testing oil: about 70ml	
Stirring Rate	Procedure A: (90~120)RPM, Procedure B: (250±10)RPM	
Igniting Device	Igniting source: gas(or other civilian fuels, the same below)	Electric ignition. Diameter of igniter: 0.7mm~0.8mm
Heating Device	The heating power is continuously adjustable from 0 W to 600W.	
Heating Rate	(1~12)°C/min: Controllable and adjustable	Procedure A: (5~6)°C/min, Procedure B: (1~1.5)°C/min, Procedure C: (3±0.5) °C/min
Consumption	≤650W	≤600W
Power Supply	AC220V±10%, 50Hz	
Dimension(W*D*H)	370*320*300mm	510*320*330mm
Package Size(W*D*H)	650*450*360mm	690*500*595mm
Gross Weight	19kg	34kg



BK-FP261



BK-FP261D

Leakage Tester

Application:

Leakage tester is suitable for sealing test of bags, bottles, tubes, cans and boxes in food, pharmaceutical, medical equipment, daily chemicals, automobiles, electronic components, stationery and other industries. It can also be used to test the sealing performance of the specimens after the drop and pressure resistance tests.

Features:

- * Microcomputer control, test parameters can be set, automatic testing process.
- * Hold time, test pressure, and pressure replenishment ratio can all be pre-set for one-touch operation throughout the testing process.
- * Sealed chamber is made of high quality plexiglass tubing with 15mm thickness.
- * Automatic pressure release and purge upon completion of testing, saving operational time.
- * Imported pressure sensors paired with precision relays for rapid response and stable pressure control. Integrated calibration module supports multi-point calibration for third-party verification.
- * The instrument features an integrated compressed air filtration and pressure regulation system, with an external design for easy drainage and debris removal, ensuring the safe operation of internal components.
- * To ensure uninterrupted operation, the instrument utilizes a three-power-source independent supply mode: separate power supplies for the main controller, pressure reception module, and pressure control module.



Technical Parameters:

Model	BK-ST134
Vacuum Degree Range	-90~0kPa
Vacuum Accuracy Class	Class 0.5
Resolution	0.1kPa
Pressure Acquisition Rate	2ms
Pressure Replenishment Response Speed	5ms
Original Air Pressure	0.5~0.7MPa (User-supplied, optional)
Original Air Connection	Φ6 polyurethane pipes
Control Method	Microcomputer control, automatic test procedure
Display	LCD display
Vacuum Storage Time	0~6000s (Can be enlarged)
Data Output Mode	Thermosensitive or needle type printer (Optional)
Effective Size of Vacuum Chamber	Standard: Φ270*210mm (H) Optional: Φ360*585mm (H) and Φ460*330mm (H) Note: customization is available for other sizes
Power Supply	AC 220V, 50/60Hz; 110V, 50/60Hz (Optional)
Standard Accessories	Main machine, vacuum chamber, air tube, technical documents
Optional Accessories	Air compressor, sample holder
External Size (W*D*H)	Main machine: 420*320*120mm Vacuum chamber: 300*350mm (H) (Standard)
Package Size (W*D*H)	Main machine: 530*430*250mm Vacuum chamber: 370*370*420mm
Net Weight	16kg
Gross Weight	23kg



BK-ST130



BK-ST132

Features:

- * The performance of pneumatic components is stable and reliable.
- * High quality plexiglass sealing barrel, effectively enhance the compressive strength.
- * Electronic pressure holding device, reduce mechanical wear.
- * PVC operation panel, LED display.
- * Built-in time display, convenient for users to record and observe the pressure holding time.
- * Automatic constant pressure air supply, automatic backblowing unloading pressure (Only for BK-ST132).
- * External compressed air filter device, easy to drain water and clean impurities (Only for BK-ST132).
- * Dual power supply independent power supply (Only for BK-ST132).

Technical Parameters:

Model	BK-ST130	BK-ST132
Vacuum Degree Range	-90~0kPa	
Vacuum Accuracy Class	Class 0.5	
Resolution	0.1kPa	
Original Air Pressure	0.5~0.7MPa (User-supplied, optional)	
Original Air Connection	Φ6 polyurethane pipes	
Control Method	Manual adjustment, automatic timing	Microcomputer control, automatic test
Display	LED display	
Power Mode	/	Compressed air
Vacuum Storage Time	0~9999h59min59s	0~9999s (Can be enlarged)
Effective Size of Vacuum Chamber	Standard: φ270*210mm (H) Optional: φ360*585mm (H), and φ460*330mm (H) Note: customization is available for other sizes	
Power Supply	AC 220V, 50/60Hz; 110V, 50/60Hz (Optional)	
Standard Accessories	Main machine, vacuum chamber, air tube, hand valve, power cord, technical documents	Main machine, vacuum chamber, pressure regulating filter, air tube, power cord, technical documents
Optional Accessories	Air compressor, sample holder	
External Size (W*D*H)	Main machine: 420*320*120mm Vacuum chamber: 300*350mm (H) (Standard)	
Package Size (W*D*H)	Main machine: 530*430*250mm Vacuum chamber: 370*370*420mm	
Net Weight	16kg	
Gross Weight	23kg	

Soil&Plant&Seed Instruments Solution

Soil Auger Kits



Introduction:

Soil Auger kits contains a complete set of soil borrowing accessories, which can be used to drill disturbed soil samples within 1-2 meters in soft soil areas or to drill 1-2 meters deep holes.

Soil Auger is one of the main tools for collecting soil samples. The reliability, ease of operation and mobility of the borrow drill can not only reduce the workload of soil investigation, improve the efficiency of soil borrowing, but also expand the adaptability of soil sampling.

Features:

- * The sampler is made of stainless steel, without pollution to sample
- * Pedal type, more convenient, fast, reduce the labor intensity
- * Take 15-20CM of the soil samples each time.
- * The material is hard and the shape is not easy to be bent and twisted.
- * The exterior of the soil sampler is marked with scale values, each scale is 100mm, which provides a reference for taking soil samples of different depths.
- * The soil sampling head, the connecting pipe and the handle are all connected by thread, which does not occupy the volume after disassembly, and is convenient for transportation.
- * When it is necessary to measure soil moisture data, it can be used as the connecting rod of the soil moisture sensor.
- * The depth of sampling is: 1m, 1.5m, 2m.

Technical Parameters:

Model	BK-SAK2
Function	Drill disturbed soil samples within 1-2 meters in soft soil areas or to drill 1-2 meters deep holes
Total Length	1-2m adjustable
Accessories	1 brush, 1 spanner, 1 tape on 3meters, 1 scraper, 1 handle, 1 head, and 4tubes
Package Size(L*W*H) mm	675*315*180
Gross weight (kg)	7.3

Soil Nutrient Tester

Application:

It is used to detect available nitrogen, available phosphorus, available potassium, organic matter, soil pH and soil salinity in soil, plant, chemical fertilizer.

Features:

- * LCD display.
- * Print testing date, sample number, sample items, sample contents, variety.
- * Large capacity storage (time, place, fertilizers), datum can be checked at any time.
- * Quickly test the N, P, K, organic matter, salinity, and pH in the soil, fertilizer and plants.
- * With the function of time display, can automatically record and save the time of tested sample.
- * Can set crop variety, crop yield, fertilizer variety, and automatically count the fertilizing amount.



Technical Parameters:

Model	BK-Y6A	BK-Y6PC	BK-Y7PC
Soil Nutrient	Stability	Absorbency of light drift < 0.003	
	Repeatability	Absorbency of light < 0.005	
	Linearity Errors	Red light for Copper sulfate, and blue light for potassium dichromate < 3.0%	
	Sensitivity	Red light $\geq 4.5 \times 10^{-5}$, Blue light $\geq 3.17 \times 10^{-3}$	
	Wavelength Range	Red light $620 \pm 5\text{nm}$; Blue light $440 \pm 5\text{nm}$	
	Anti-Knocking Performance	Qualified	
PH	Testing Range	1~14	
	Error	$\pm 0.5\%$	
Salinity	Testing Range	0.01%~1.00%	
	Error	$\pm 5\%$	
Function	Test N, P, K, organic matter, soil pH, soil salinity, with storage function, built-in the amount of nutrients needed for growth of 73 kinds of crops, can provide guidance for fertilizing amount according to needs, with printing function	On the basis of BK-Y6A, with a software, be able to connect to computer for data storage, tele-transmission and printing	Moisture: Moisture unit: % (m/m) Accuracy: $\pm 2\%$ Resolution: 0.1% Testing range: 0~100% On the basis of BK-Y6PC, but can measure soil moisture
Power Supply	220V/110V $\pm 10\%$, 50/60Hz		
Package Size(W*D*H)	670*390*230mm		
Gross Weight	11kg		

Multi-parameter Soil Meter



Application:

Handheld Multi-parameter Soil Meter can acquire different parameters with different sensors and the tested parameter would be air temperature, humidity, soil temperature, soil moisture. It is widely used in facilities agriculture, forestry, horticulture, animal husbandry and other fields, and fulfills to carry out conduct of automatically monitor, automatic control and intelligent management to the facilities for comprehensive agricultural ecological information.

Technical Parameters:

Model		BSM-01	BSM-02	BSM-03	BSM-05
Soil Moisture	Range	0~100%			
	Accuracy	±3%			
	Resolution	0.1%			
Soil Temperature	Range	/	-50°C~100°C		
	Accuracy	/	±0.5°C		
	Resolution	/	0.1°C		
Air Temperature	Range	/	-40°C~80°C		
	Accuracy	/	±0.4°C		
	Resolution	/	0.1°C		
Air Humidity	Range	/	0~100%RH		
	Accuracy	/	±0.3%RH		
	Resolution	/	0.1%RH		
Dew Point	Range	/	-40°C~120°C		
	Accuracy	/	±0.4°C		
	Resolution	/	0.1°C		
Storage Capacity	Almost up to 30,000 groups in handset, and standard equipped with 4G Micro SD. Data-collection interval: 5min~99hour				
Power Supply	8.4V lithium battery				
Working Current	Stand-by power consumption 10mA, working power consumption according to the configuration.				
Package Size(mm)	415*340*155	390*420*200	390*420*200	430*390*260	
Gross Weight(kg)	2.6	3.5	3.5	5.2	

Digital Soil Water potential Meter



Features:

- * High accuracy and high resolution can test soil temperature and water potential at the same time.
- * Easy to operate, portable, flexible, can purchase one set with multi-probes.
- * Automatically get the peak data of water potential.
- * With time set, full scale set auto save function.
- * Record temperature, water potential, time and storage No at the same time.
- * Automatically turns off function.

Technical Parameters:

Model	BK-SWP2
Max Load	100kpa
Resolution	0.01kpa
Accuracy	±1FS
Soil Temperature Testing Range	--55°C~150°C
Temperature Accuracy	±0.5
Probe Quantities	3
Function	Can test both soil water potential index and soil temperature index
Power Supply	9V battery
Packing Size	340*340*60mm, 550*60*60mm
Gross Weight	3.5kg

Soil PH-Moisture Meter

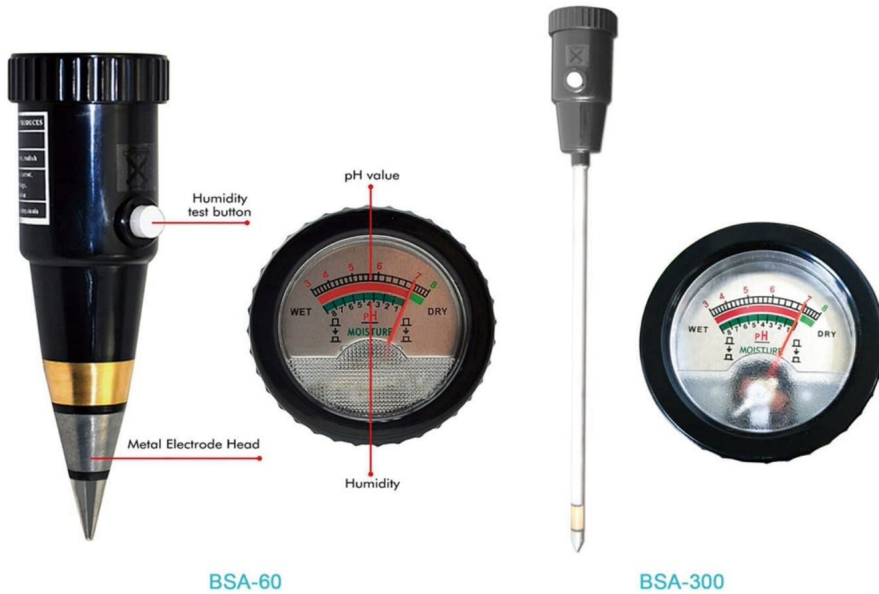

Introduction:

The soil PH is an important factor to limit the crops production and the quality. This instrument is simple and convenient, can directly insert the soil.

Technical Parameters:

Model	BSA-60	BSA-300
Function	Test depth: 6cm, suitable for surface soil acidic test	Test depth: 30cm, suitable in the depth soil acidic test
PH Range	3~8 PH	
PH Accuracy	±0.2PH	
Moisture Range	1 - 8%	
Moisture Accuracy	±1%	
Package Size(L*W*H) mm	200*110*120	590*150*135
Gross weight (kg)	0.5	0.5

Soil Moisture, Temperature, And Salinity Recorder

Features:

Handset:

- * Small and exquisite, easy to carry and LCD display.
- * Collect settings: working unattended can be set to timing or manual collect data, recording and save data automatically.
- * Both AC and DC available, internal lithium battery: 8.4v 1500mAh, with function: charging protection, low voltage prompt. Also can be placed for a long time to record location.
- * Storage capacity: up to 30,000 groups in handset, and standard equipped with 4G Micro SD.
- * Data can be read on handset and also import to PC.
- * Power-off memory function: data already saved in SD card won't lose when lose power.
- * Probe to probe Consistency, handset can connect different kinds sensor by concentrator without influence on accuracy.
- * Auto detection: when sensor connects to handset, you can search different sensor.
- * Synchronous detection: 32 channels to detect same time as you combine.
- * RS485 wire communication, sensor communication cables could reach about 100 meters.
- * Low-power design, equipped with system monitor and protection function to avoid short circuit or interference from external.



Software:

- * Showing the curve trends of each parameter, Max, Min, and Avg. Zoom in and out function.
- * Coloring the overrun area function which is visual display.
- * Save the data in EXCEL format as a copy.
- * Be able to view period of parameter or graph, and can be printed.
- * All curvilinear coordinates can be set and move, which make analysis easier.

Technical Parameters:

Model	SMTS-3P
Function	Detect soil moisture, content temperature, and salinity same time
Soil Temperature	Unit: °C; Range: -40°C~100°C; Accuracy: ±0.5°C; Resolution: 0.1°C
Soil Moisture Content	Unit: %(m³); Range: 0~100%; Response time: ≤ 2s; Relative error: ≤3%
Soil Salinity	Range: 0~19.99ms/cm; Sensors can be buried into soil.
Storage Capacity	Almost up to 30,000 groups in handset, and equipped with 4G Micro SD.
Data-Collection Interval	5min~99hour
Working Power Supply	Battery: 8.4V lithium battery; Power Adapter:100~240V 50/60Hz
Working Current	Stand-by power consumption 10mA, working power consumption according to the configuration.
Package Size(L*W*H) mm	450*420*140
Gross weight (kg)	4

Portable Soil Heavy Metal Analyzer



Features:

- * It can analyze 34 kinds of standard elements of K, Ca, Ti, V, Cr, Mn, Fe, Co, Ni, Cu, Zn, As, Se, Rb, Sr, Y, Zr, Nb, Mo, Ag, Cd, Sn, Sb, W, Re, Pd, Au, Hg, Pb, Bi, Cs, Ba, Th, U.
- * Small size, light weight, easy to carry, can be directly brought to the field for detection.
- * Can analyze various types of soil, field soil, sand, sludge, solid waste, soil, mud, etc.
- * High-speed processing chip, advanced algorithms and efficient software to make the instrument analysis faster.
- * Can analyze the soil directly without sample, the whole process only needs 80s.
- * Industrial resistance touch screen, compared to the capacitive screen has a better backlight performance, in the field of light is still clearly visible, while the field of special environment to avoid the risk of glove removal.
- * It works at -20°C to 50 °C, when the temperature humidity is beyond the scope of application, will automatically alarm.
- * Can be combined with the built-in GPS.

Technical Parameters:

Model	SHMA-B
Excitation Source	New integrated miniature X-ray tube, 6-50KV pressure/0-200uA tube flow with free adjustment, Ag target(standard)
Probe	With high sensitivity silicon drift detector, accuracy:<125 eV
Range	All element from Mg to U
Data	Built-in 32G memory for storing 300K spectral data and spectra.
Heat Dissipation	With a dedicated T-slot heat sink to improve the heat dissipation of the instrument without waiting for the detector to cool frequently
Safety	The package with Waterproof, dust-proof and shockproof
Supply Power	Battery: 7.2V lithium battery Power Adapter:100~240V 50/60Hz
External Size(L*W*H) mm	254*79*280
Net Weight (kg)	1.6Kg (with battery)
Package Size(L*W*H) mm	400*130*360
Gross Weight (kg)	3

Portable Soil Irrrometer Tensiometer



Introduction:

Soil Irrrometer tensiometer is made up of pressure gauge, acrylic tube and ceramic probe, after the acrylic tube filled with water, ceramic probe gets wet and it can prevent outside air into the ceramic probe. When there is pressure difference between measured soil water potential and tensiometer, the water in tensiometer will infiltrate into the measured soil until the balance reached. So at that moment, the value shown on the pressure gauge is the measured soil water potential.

Technical Parameters:

Model	Length(mm)	Testing Range	Package Size(L*W*H) mm	Gross weight (kg)
BST-15	150	0~1 Bar (1 Bar = 100 Kpa)	370*225*60	0.5
BST-30	300		440*150*70	1.0
BST-45	450		560*150*70	1.0
BST-60	600		700*150*70	1.2
BST-90	900		1000*150*70	1.5
BST-120	1200		1335*140*90	1.5

* Length can be made as customized. (Standard length is the length of transparent polycarbonate tube in the middle of tension meter tube)

Soil Respiration Meter



Introduction:

Soil respiration measurement is the main way for carbon to return to the atmosphere from terrestrial ecosystem, and it is also the characterization of life activities in soil. Accurate measurement of its release is the key to evaluate the biological process in ecosystem; By monitoring soil respiration and its related parameters, the response of root box soil microorganisms to climate change can be estimated. Soil CO₂ flux is affected by many complex physical and biological processes in time and space. Long-term, continuous and accurate measurement of soil carbon flux is of great significance to the study of terrestrial ecosystem carbon flux. The soil respiration meter can simultaneously display the CO₂ concentration, soil temperature, photosynthetic effective radiation intensity, flow, air temperature and humidity of the respiration chamber.

Features:

- * Intuitive display: Chinese LCD 160*256 dot matrix, simple operation and clear interface.
- * Data storage: Large Capacity SD card is used to store data, which has large data storage capacity and convenient export.
- * Data acquisition: CO₂ concentration, soil temperature, air temperature, air humidity, photosynthetic effective radiation intensity, gas flow and other indicators can be collected at the same time. The stability, accuracy, attention and time response of the measurement are very good.
- * Easy to use: small size, light weight, portable, single person operation, arbitrary movement, clear gas circuit and circuit connection.
- * Wide application: users can choose breathing chambers with different volumes or other purpose breathing chambers, which can be widely used for the determination of respiration of soil, fruits and vegetables, seeds, plants and so on.
- * Convenient power supply: it is equipped with standardized maintenance free lithium battery, which can be used for more than 10 hours at a time. It can also be powered by AC and DC.
- * Instrument protection: microelectronic flowmeter is adopted, with the function of prompt protection for gas path blockage.

Technical Parameters:

Model	SRM-3051T
Carbon Dioxide Detection	Infrared carbon dioxide detection module Measurement range: 0~5000ppm Linearity: $\leq \pm 1\%$ F.S Repeatability: $\leq \pm 1\%$ Response time: $\leq 15s$ Zero drift: $\leq \pm 2\%$ f.s/24h End drift: $\leq \pm 2\%$ f.s/24h
Soil Temperature Detection	Micro fast response PT100 platinum resistance Measurement range: 0~60 °C Resolution: 0.1 °C, Accuracy: ± 0.3 °C
Air Temperature Detection	Inlet temperature detection module Measurement range: - 20~95 °C Resolution: 0.1 °C Accuracy: ± 0.2 °C
Air Humidity Detection	Inlet humidity detection module Measurement range: 0~100% Resolution: 0.1% Accuracy: $\pm 1.8\%$
Light Detection	Silicon photocell with correction filter, response spectrum 400nm-700nm Measurement range: 0-3000umol / m ² / s ⁻¹ Resolution: 1umol / m ² / s ⁻¹ Accuracy: $\pm 5\%$ umol / m ² / S ⁻¹
Flow Detection	Microelectronic flowmeter Measurement range: 0~1.5l/m Resolution: 0.01l/min Accuracy: $\pm 2\%$
Soil Respiration	Volume 1.0L.
Storage	Storage mode: 2GB memory card storage Storage format: TXT document
Working Power Supply	Battery: 8.4V lithium battery; Power Adapter: 100~240V 50/60Hz
Package Size(L*W*H) mm	550*350*250
Gross Weight (kg)	8

Non-nuclear Soil Density Meter



Applications:

It is used for the measurement of wet density and moisture content of compacted materials in the following areas: excavation and backfill construction; underground passages, basements and foundations; backfilling and ditches, garbage; subgrade foundations and trench backfilling. It is mainly suitable for clay and non-cohesive soils, and can also be used for lime or cement improved soils, gravel soils and other soils.

Features:

- * Fast, reliable, lightweight, robust, accurate, and reproducible real-time readings.
- * Adopt high-quality and reliable point-to-point RF technology.
- * 2-3 minutes to display the measurement results.
- * Using digital DDS frequency synthesis technology, no calibration is required, and there will be no data drift during use.

Technical Parameters:

Model	BK-NDM4
Wet Density Accuracy	0-2% of standard tests
Water Content Accuracy	0-3% of standard tests
Display	5 inches touch screen
Detection Depth	Standard 150mm, maximum depth 300mm (need to customize steel needle)
Storage	50000 pcs data
USB Port	Yes
Power Supply	12V, 2600mAh lithium rechargeable battery, continuous work for 20 hours
Packing Size	190*160*70mm
Gross Weight	8.5kg

Ground Bearing Capacity Detector



Applications:

It is also called Micro Penetrator. It is mainly used to test the compactness and uniformity of large-area filling engineering after rolling. Such as highways, roads and bridges, municipal drainage, oil pipelines, water conservancy guards, industrial and civil construction. It is characterized by lightness, flexibility and speed, and can track rolling site monitoring anytime, anywhere.

Technical Parameters:

Model	BK-GBD12
Measuring Depth	0-30cm
Precision	≤0.5%
Storage	1000 groups of data
Configuration	Probe rod: 3 pcs Probe: 2 pcs Test data sheet: 1 set Instrument aluminum alloy box: 1 pc Computer data processing software: 1 set
Packing Size	415*370*170mm
Gross Weight	6kg

Soil Relative Density Meter



Applications:

- * Airport runway.
- * Excavation and backfill construction.
- * Channel.
- * Road and railway foundation construction.
- * Construction of public facilities.
- * The construction of the dam.
- * Yard cover construction.
- * Building foundation.

Technical Parameters:

Model	BK-SRM1
Metal Volume 1	250ml, diameter 5cm, height 12.7cm
Metal Volume 2	1000ml, diameter 10cm, height 12.75cm
Hammer	Mass 1.25KG, diameter 2cm, 10cm, drop height 15cm
Long Neck Funnel	Neck diameter:1.2cm
Conical Plug	Diameter:1.5cm
Sand Surface Smoother	Cruciform
Packing Size	480*230*160mm
Gross Weight	11kg

Soil Compaction Tester



Features:

- * In the data viewing mode, you can view the data on the host or import it into the computer for viewing and analysis.
- * The data that has been saved in the host will not be lost due to unexpected power failure.
- * Display each sensor parameter and process curve trend, maximum value, minimum value, average value, zoom in, zoom out, etc.
- * The measurement data of each sensor has been saved in EXCEL format. The data report and curve graph can be viewed by time period and can be printed by computer. The curve coordinates can be moved and the historical data can be clearly analyzed.
- * It has the function of distinguishing the color of the out-of-limit area, and the display is intuitive and convenient.

Technical Parameters:

Model	SCM-3
Recording Time Interval	5 minutes to 99 hours
Longitude	0-180°
Latitude	0-90°
Measuring Range	0~10000kPa, 0~100Kg/cm ² , 0~1000N/cm ²
Measuring Accuracy	±0.5%FS
Measuring Depth	375mm
Working Power Supply	7.4V large capacity lithium battery
Packing Size	600*200*100mm
Gross Weight	3kg

Soil Compaction Meter

Features:

Software:

- * Showing the curve trends of each parameter, Max, Min, and Avg. Zoom in and out function.
- * Coloring the overrun area function which is visual display.
- * Save the data in EXCEL format as a copy.
- * Be able to view period of parameter or graph, and can be printed.
- * All curvilinear coordinates can be set and move, which make analysis easier.

Handset:

- * Small and exquisite, easy to carry and LCD display.
- * Collect settings: working unattended can be set to timing or manual collect data, recording and save data automatically.
- * Both AC and DC available, internal lithium battery: 8.4v 1500mAh, with function: charging protection, low voltage prompt.
Also can be placed for a long time to record location.
- * Storage capacity: up to 30,000 groups in handset, and standard equipped with 4G Micro SD.
- * Data can be read on handset and also import to PC.
- * Power-off memory function: data already saved in SD card won't lose when lose power.
- * Probe to probe Consistency, handset can connect different kinds sensor by concentrator without influence on accuracy.
- * Low-power design, equipped with system monitor and protection function to avoid short circuit or interference from external.



Technical Parameters:

Model	SCM-750-II
Function	General type, display soil compaction(KPa, kg/cm ² , N/cm ²)directly, with data saving function
Range	0~10,000KPa; 0~100kg/cm ² ; 0~1,000N/cm ² (switchable)
Depth	0~375mm (measuring rod is 400mm)
Accuracy	±0.5% FS
Position Accuracy	Three decimal ±0.05(≤50m)
Storage Capacity	Almost up to 30,000 groups in handset, and equipped with 4G Micro SD
Data-Collection Interval	5min~99hour
Working Power Supply	Battery: 8.4V lithium battery; Power Adapter:100~240V 50/60Hz
Working Current	Stand-by power consumption 10mA, working power consumption according to the configuration
Package Size(L*W*H) mm	540*170*300
Gross Weight (kg)	4

Soil Conductivity Meter

Application:

It is widely used in soil moisture detection, dry farming, water-saving irrigation, precision agriculture, forestry, geological exploration, plant cultivation, water conservancy, environmental protection and other fields.



Technical Parameters:

Model	BK-SCM1
Range	0~23ms/cm
Accuracy	±2%
Resolution	0.01mS/cm
Temperature Compensation	0-50 °C
Power Supply	110-240V, 50/60Hz
Packing Size	390*200*200mm
Gross Weight	2kg

Soil Permeameter

Application:

This instrument is used to measure the permeability of clayey soil under variable water head.



Technical Parameters:

Model	BK-SPM55
Sample Size	φ61.8mm, height: 40mm
Product Size	φ118mm (except the nozzle) height about 155mm
Net Weight	3.5kg
Packing Size	320*220*280mm
Gross Weight	5kg

Soil Bulk Density Tester

Application:

The soil bulk density meter is suitable for on-site determination of the density of coarse-grained soil. It has a chassis, a sanding funnel, a bulk density bottle, and the valve is structurally strong and durable, and is made of stainless steel. The volume of the sand bottle is strictly calculated and the calibration error of the electronic balance is within 5g, which provides reliable data for the experiment. The sanding funnel is 135mm high and the volume of the sand bottle is 4L. The product also has a series of products (plastic, Iron sheet) is available.

Principle:

Using the ring cutter method, the guide rod and the drop hammer are used to apply natural pressure to the ring cutter without affecting the original structure of the soil.

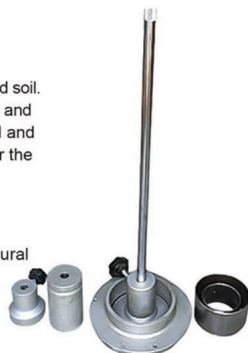

Technical Parameters:

Model	BK-SDT4
Configuration	2 ring cutters, 1 orientation cylinder, 1 guide rod, 1 drop hammer, 2 knobs
Packing Size	385*280*200mm
Gross Weight	14kg

Soil Aggregate Structure Meter

Introduction:

Aggregate structure is the basis of fertility. The relationship between aggregate structure and soil fertility is mainly manifested in regulating the contradiction between soil moisture and air; coordinating the contradiction between soil nutrient consumption and accumulation; stabilizing soil temperature; improving soil tillage, which is conducive to the extension of crop root system.

Features:

- * Stable performance and low failure rate.
- * Stable No noise, adjustable speed.
- * Stable With the function of timing setting, the running time of tube display is concise and clear.
- * Stable With emergency stop switch, it is convenient to cut off power in time when abnormal phenomena occur in the test and stop working.



Technical Parameters:

Model	SAS-100
Oscillation Frequency	4-45 times / min
Operation Mode	Vertical movement, stroke 50mm
Timing Range	0-60 minutes
Speed	1450 rpm
Standard Configuration	Sieve: Size: 20cm, height: 5cm Specification: 10mm, 7mm, 5mm, 3mm, 2mm, 1mm, 0.5mm, 0.25mm Material: stainless steel Oscillating rack: 3 supports simultaneous determination of 3 samples
Power Supply	220V±20% 50/60Hz, 120W
External Size(L*W*H) mm	512*512*760
Package Size(L*W*H) mm	610*590*950
Gross Weight (kg)	53

Leaf Thickness Gauge

Introduction:

The leaf thickness Gauge is mainly used to measure the leaf thickness of plants, so as to reflect the growth and nutritional status of plants through the measurement data.



Technical Parameters:

Model	LTG-1
Measuring Range	0~6mm
Resolution	0.01mm
Accuracy	0.015mm
Contact Area	Φ10 mm
Reader	Pointer
Net Weight	1kg

Plant Water Potential Analyzer



Features:

- * MPa and Bar are two measuring units for choice.
- * Powerful storage function, can store 4000 records.
- * Delete all measurement data with one click.
- * Upload the computer through the USB cable.
- * The data can be viewed in the form of reports, and you can choose the period of query.
- * Store the record data in EXCEL format backup and save, convenient call later.

Technical Parameters:

Model	PWP-II
Measuring Range	0~3.5Mpa
Accuracy	0.01Mpa
Measuring Mode	Automatic and manual, one-button switch
Display	LCD
Battery	12V/2.5AH lithium battery with clock function
Power Supply	220V 50/60Hz
External Size	630*400*310mm, 560*400*280mm
Package Size	685*445*360mm, 610*440*340mm
Net Weight	28kg
Gross Weight	32.3kg

Root Scanner



optional

Introduction:

Root analysis system is based on image recognition technology, it is professionally used for root analysis of plants after washing the roots in vitro. It has the characteristics of convenience, efficiency and high accuracy, which can improve the work efficiency of practitioners, reduce labor costs.

Features:

- * Clear interface design, modular function design.
- * User learning cost is lower, operation is more convenient and smoother.
- * The analysis results are more accurate.

Technical Parameters:

Model	RS-A
Power Supply	100~240V, 50/60Hz
Optional Accessory	computer
Package Size	805*235*395mm
Net Weight	8kg
Gross Weight	9.7kg

Overall Analysis Parameter:

Model	RS-A	
Root Tip	Number: the total number of root tips, equal to the number of termination points	
	Range	0~1000
	Accuracy	error <5%
Root System	Length: total root system length, including main root and secondary roots	
	Range	0~10000mm
	Accuracy	error <3.65%
	Average Diameter: the average diameter of the root system	
	Range	0~20mm
	Accuracy	error <0.04%
	Projected Area: the projected area of the root system as a whole	
	Range	0~200000mm ²
	Accuracy	error <4.02%
	Surface Area: the overall surface area	
	Range	0~1000000mm ²
	Accuracy	error <3.75%
Volume: overall volume		
Range	0~2000000000mm ³	
Accuracy	error <3.82%	

Topological Analysis Parameter (requires relatively complete root system):

Model	RS-A	
Quantity: the sum of the number of roots at all levels		
Range	0~100	
Number of Connections: the sum of the number of connections on the side roots at all levels		
Range	0~100	
Length: the sum of the lengths of the lateral roots at all levels		
Range	0~10000mm	
Diameter: the average diameter of each side root		
Range	0~20mm	
Surface Area: the sum of the surface area of each side root		
Range	0~1000000mm ²	
Volume: the sum of the volume of each side root		
Range	0~2000000000mm ³	
Projected Area: the sum of the projected area of each side root		
Range	0~200000mm ²	

Leaf Temperature Gap Meter



Features:

- * Small size, easy to carry.
- * LCD display, friendly man-machine interface.
- * Reasonable mechanism, accurate measurement, simple use, good stability and maintenance free.
- * Perfect power management scheme, it will shut down automatically when there is no key operation for a long time.

Technical Parameters:

Model	LTG-A
Measuring Range	0°C~60°C
Resolution	0.1 °C
Reaction Time	< 3 seconds
Measurement Error	±0.5°C
Linearity	maximum offset 1%
Storage	SD card storage(2GB)
Battery	4.2V rechargeable lithium battery
Power Supply	110V~240V, 50/60Hz
Working Temp	0°C~75°C
Package Size	270*210*140mm
Net Weight	0.5kg
Gross Weight	1kg

Plant Disease Tester



Introduction:

The Plant Disease Tester can accurately diagnose the vegetable diseases pathogens in the early stages of infection, and also can help farmers to determine the varieties of pesticide use quickly and accurately, then to reduce the losses and increase the efficiency.

Application:

Applicable to a variety of crops, plants, fruits, vegetables and tea, etc.

Features:

- * Various types of plant stalk, stem, leaf and fruit can be sampled.
- * Large - screen liquid crystal display and prompts, easy to use.
- * Automatic control, automatic calculation, automatic calibration, automatic printing, and has high precision.
- * Quickly diagnose a variety of viruses and bacteria.
- * Continuous testing of multiple samples, low-cost test.
- * Automatic printer integrated design, can be connected to the computer and the printer.

Technical Parameters:

Model	PDT-II
Test Speed	Single Test: 60 parts/h
	Continuous Test: 120 parts/h
Diagnosis Type	Fungus: botrytis, downy mildew, damping off, yellows, morning and late Pestilence, stem wilt, gummy stem blight, scab, black spot, rust disease, ring spot, powdery mildew, alternaria leaf spot, shot hole, full rot
	Bacterial Diseases: ulcers disease, bacterial spot, soft rot, bacterial wilt
	Viral Diseases: stubby disease, plexus dwarf, mosaic virus disease
Print Method	Thermal printer
Consumption	≤30W
Power Supply	220V, 50/60Hz
Package Size	560*410*295mm
Net Weight	8kg
Gross Weight	10kg

Portable Leaf Area Meter

Application:

Portable leaf area meter is mainly used for determination plant leaf, is a portable instrument can work in the field. The leaf area and related parameters of the leaves can be measured accurately, quickly and without damage, the area of the plant leaves and other flakes can also be measured. Widely used in agriculture, meteorology, forestry and other departments.



Technical Parameters:

Model	LAM-A	LAM-B
Unit	Millimeter, Square Centimeter	Millimeter, Square Millimeter
Precision	±2%	
Resolution	0.01cm ²	
Measuring Length	≤1000mm	≤ 2000mm
Measuring Width	≤160mm	≤ 210mm
Thickness	≤8mm	
Data Capacity	≥1000Groups	
Packing Size(W*D*H)	390*230*220mm	580*250*200mm
Gross Weight	2kg	2.8kg

Features:

- * Easy to operate. With Micro-computer technology, LCD display.
- * Test many kinds of data, such as leaf area, average area, length of leaf, width of leaf, perimeter and ratio of length and width.
- * USB link with computer by software, you can put the data into computer, and convert data to excel format and print.
(Only for LAM-B)

Portable Leaf Area Meter

Application:

Portable leaf area meter is mainly used for determination plant leaf, is a portable instrument can work in the field. The leaf area and related parameters of the leaves can be measured accurately, quickly and without damage, the area of the plant leaves and other flakes can also be measured. Widely used in agriculture, meteorology, forestry and other departments.

Features:

- * Easy to operate. With Micro-computer technology, LCD display.
- * Test many kinds of data, such as leaf area, average area, length of leaf, width of leaf.
- * USB link with computer by software, you can put the data into computer, and convert data to excel format and print.

Technical Parameters:

Model	LA-B
Unit	Millimeter, Square Centimeter
Precision	±2%
Measuring Length	0~1000mm
Measuring Width	0~155mm
Date Capacity	10000Groups
Package Size(W*D*H)	400*200*150mm
Gross Weight	2kg



Portable Chlorophyll Meter



Application:

Chlorophyll Meter is able to measure chlorophyll content of plants and leaf temperature. Chlorophyll content and leaf nitrogen content have a very close relationship. Thus, chlorophyll content can reflect plants demand for nitro. Using the instrument can put nitrogen fertilizer reasonably, improve utilization of nitrogen and protect environment.

Technical Parameters:

Model	PCM-B
Measuring Area	2mm*2mm
Measuring Mode	2-wavelength concentration difference of optical methods
Sensors	Silicon semiconductor photodiode
Display Mode	Measuring value: 3 digits liquid crystal display Measuring time: 2 digits liquid crystal display
Min Measuring Interval	<3s
Measuring Range	0.0-99.9 SPAD, 0-60°C
Accuracy	±1.0 SPAD, ±1°C
Repeat	±0.3 SPAD
Power Supply	4.2V, -2000Mah rechargeable Li battery
Memory Capacity	SD card, 2GB
Package Size(W*D*H)	300*250*150mm
Gross Weight	1kg

Portable Chlorophyll Meter



Application:

Chlorophyll Meter is able to measure chlorophyll content of plants and leaf temperature. Chlorophyll content and leaf nitrogen content have a very close relationship. Thus, chlorophyll content can reflect plants demand for nitro. Using the instrument can put nitrogen fertilizer reasonably, improve utilization of nitrogen and protect environment.

Features:

- * Enter the name of the plant, the standard nitrogen content and utilization, the standard fertilizer can be directly calculated.
- * Chlorophyll, leaf temperature are displayed on same screen at the same time, and can be stored at the same time.
- * USB interface can be connected to the computer to export the measured data, to facilitate the management and analysis of plant nutrients. (Only for CM-B)

Technical Parameters:

Model	CM-B
Measuring Area	2mm*2mm
Measuring Mode	2-wavelength concentration difference of optical methods
Sensors	Silicon semiconductor photodiode
Display Mode	Measuring value: 3 digits liquid crystal display Measuring times: 2 digits liquid crystal display
Min Measuring Interval	< 3s
Measuring Range	0.0~99.9 SPAD; -10~99.9°C
Accuracy	±3.0 SPAD; ±0.5°C
Repeat	±0.3SPAD; ±0.2°C
Power Supply	4.2V -2000Mah rechargeable Li battery
Memory Capacity	30Kb, automatically calculate and show the average
Package Size(W*D*H)	270*250*200mm
Gross Weight	2kg

Plant Canopy Analyzer

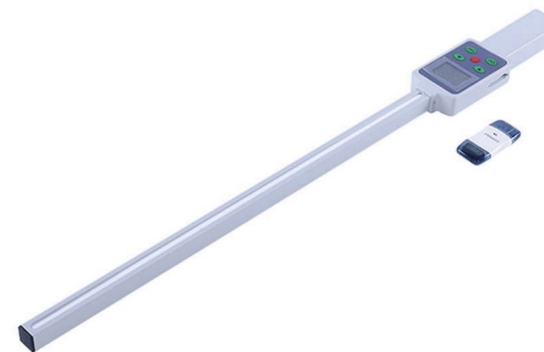

Introduction:

Plant canopy analyzer is widely applied for farming production and agricultural research, canopy energy resource investigation, measure the light interception among plant canopy, and research the relation between plant growth and development, production quality and light utilization.

Features:

- * Integration design, it includes LCD, operation buttons, SD card plug and measure probe.
- * Menu operation is easy, small size and portable.
- * Large store capacity. Convenient data management.
- * Low power dissipation with reasonable power management with automatically shut down and restart action.
- * Manual and auto measure method are available.

Technical Parameters:

Model	PCA-1000
Measuring Range	0~2700 μ mol m^2/s
Resolution	1 μ mol m^2/s
Response Time	10 μ s
Auto-Collecting Interval	1~99 min
Auto-Collecting Times	1~99 times
Store Capacity	2GB(SD card)
Meter Length	750mm
Probe Length	500mm
Qty of Sensors	25pcs(standard)
Power Supply	2*AA batteries
Working Temp	0~60°C
Working Humidity	100%RH
Package Size	810*210*160mm
Net/Gross Weight	2/3kg

Plant Photosynthesis Meter



Application:

The Plant Photosynthesis Meter applies for measuring Photosynthesis rate of crops, fruits and vegetables, grass etc.

Features:

- * LCD widescreen display.
- * Use - friendly: small in size, light - weight, portable, single - person operation, clear connection of gas circuit and electrical circuit, the leaf chamber open and lock automatically.
- * Excellent performance: high stability, accuracy, repeatability, and good time response. It is able to measure simultaneously Pn, CO₂, PAR, T etc.
- * Widely application: equip different type leaf chamber, it can widely apply for field crop, fruits and vegetables, forest and wood, grass etc. equip standard maintain - free Li - Ion, AC/DC are available, RS232 available.

Technical Parameters:

Model		PPM-C
CO ₂	Measure Range	0~1500ppm
	Accuracy	3%ppm
Leaf Temperature	Measure Range	0~50°C
	Accuracy	±0.5°C
Air Temperature	Measure Range	0~50°C
	Accuracy	±0.5°C
PAR	Measure Range	0~2500μmol·m ⁻² ·s ⁻¹
	Accuracy	<5μmol·m ⁻² ·s ⁻¹
RH(chamber humidity)	Measure Range	0~100%
	Accuracy	2%
Power Supply		110~220V, 50/60Hz
Packing Size(W*D*H)		700*500*300mm
Gross Weight		10kg

Plant Nutrition Analyzer



Application:

The Plant Nutrient Analyzer simultaneously saves three parameters (chlorophyll, nitrogen content and leaf temperature).

Plant chlorophyll, nitrogen content and leaf temperature are important nutrients. They are an important basis for plant fertilization and irrigation.

Features:

Rapid determination: Simultaneous determination of plant chlorophyll, nitrogen and leaf temperature.

It can save chlorophyll, nitrogen and leaf temperature data at the same time.

Non-destructive testing of plants is fast and does not affect plant growth.

Manual measurement mode.

Testing objects: nitrogen, chlorophyll, leaf temperature, and leaf humidity.

Technical Parameters:

Model		PNA-4
Chlorophyll	Measure Range	0.0~99.9SPAD
	Accuracy	±1SPAD
Nitrogen	Measure Range	0.0~99.9mg/g
	Accuracy	±5%
Leaf Temperature	Measure Range	- 10~99.9°C
	Accuracy	±0.5°C
Leaf Humidity	Measure Range	0.0~99.9RH%
	Accuracy	± 0.5%
Power Supply		4.2V 2000mah Recharge Li - ion battery
Packing Size(W*D*H)		290*295*140mm
Gross Weight		1.5kg

Plant Culm-strength Meter



Features:

- * High precision, high resolution, easy operation, easy to carry.
- * Automatically save test pressure, time and test serial number.

Technical Parameters:

Model	PCM-1A	PCM-1B
Max Load	50N	500N
Load Accuracy	±0.5%	
Resolution	0.01N	0.1N
Culm Width Range	0~100mm	
Unit	N, kg	
Output Interface	RS232	
Power	9V battery	
External Size(W*D*H)	295*130*36mm	
Net Weight	0.6kg	
Packing Size(W*D*H)	315*220*105mm	
Gross Weight	1.6kg	

Plant Transpiration Rate Meter



Features:

Multiple parameters tested: test air temperature, leaf temperature, air humidity, PAR etc at same time, and count the transpiration rate and Stomatal conductance accordingly.

Small size, light, portable and one - person operation.

Widely application: with different leaf chamber, the meter is able to be used in field crops, fruit and vegetables, hay etc which are in different shape.

Technical Parameters:

Model	PTRM-1000	
Air Temperature	Range	0~50°C
	Resolution	0.1°C
	Error	±0.2°C
Leaf Temperature	Range	0~50°C
	Resolution	0.1°C
	Error	±0.2°C
Air Humidity	Range	0~100%
	Resolution	0.1%
	Error	≤±3%
PAR	Range	0~2500μmol·m ⁻² ·s ⁻¹
	Accuracy	<5μmol·m ⁻² ·s ⁻¹
Size of Leaf Chamber	55*20mm, customized available	
Work Environment	Temperature: 20°C~50°C; Relative humidity: 0 - 100% (without condensation of moisture)	
Power	DC7.4V Li - ion Battery, 7 - 9hours continuously working	
Display	320×160 lattice	
External Size(W*D*H)	260*260*130mm	
Net Weight	3.25kg	
Packing Size(W*D*H)	560*360*250mm	
Gross Weight	9kg	

Fruit And Vegetable Respirator



Introduction:

Fruit and vegetable respirator is specially used to test and research fruit and vegetables under the conditions of normal temperature, cold storage, supermarket freezers and so on. It can choose different respiratory chambers according to the size of fruit and vegetables which can speed up the balance and measuring time. It has the characteristics of multifunction, high precision, fast, efficiency and convenience.

Features:

- * High precision, accurate measurement.
- * Uniform temperature control.
- * Temperature and humidity display and directly getting concentration values.
- * Can measure constantly.

Technical Parameters:

Model	BK-FVR3051	
CO ₂	Min Measuring Range	0~1000ppm
	Linearity	≤±2%F·S
	Repeatability	≤±1%
	Response Time	≤15s
	Zero Shift	≤±2%F·S/24h
	Destination Shift	≤±2%F·S/24h
O ₂	Measuring Range	0~25%
	Linearity	≤±2%F·S
	Repeatability	≤±1%
	Response Time	30s
	Zero Shift	≤±2%F·S/24h
	Destination Shift	≤±2%F·S/24h
Temp	Measuring Range	0~50°C
	Resolution	0.1°C
	Accuracy	±0.2°C
Humidity	Measuring Range	0~100%
	Resolution	0.1%
	Accuracy	±0.2%F·S
Pre-Heating Time	2 hours	
Power Supply	110~240V, 50/60Hz	
Respiratory Chamber	Standard:Φ120*170mm, Φ60*90mm, Φ40*80mm	
External Size	320*483*133mm	
Package Size	505*190*340mm	
Net/Gross Weight	9/11kg	

Fruit And Vegetable Respirator



Introduction:

Fruit and vegetable respirator is specially used to test and research fruit and vegetables under the conditions of normal temperature, cold storage, supermarket freezers and so on. It can choose different respiratory chambers according to the size of fruit and vegetables which can speed up the balance and measuring time. It has the characteristics of multifunction, high precision, fast, efficiency and convenience.

Features:

- * Simple operation, clear interface.
- * Large capacity SD card storage data, data storage, easy to export.
- * Calibration function, boot can choose whether to calibrate, improve the accuracy of the instrument.
- * Equipped with special software to calculate respiratory intensity.
- * The gas flow can be adjusted.

Technical Parameters:

Model	BK-FVR10	
CO ₂	Min Measuring Range	0~2000ppm
	Linearity	≤±1%F·S
	Repeatability	≤±1%
	Response Time	≤15s
	Zero Shift	≤±2%F·S/24h
	Destination Shift	≤±2%F·S/24h
O ₂	Measuring Range	0~30%
	Linearity	≤±2%F·S
	Repeatability	≤±1%
	Response Time	30s
	Zero Shift	≤±2%F·S/24h
	Destination Shift	≤±2%F·S/24h
Temp	Measuring Range	-20~95°C
	Resolution	0.1°C
	Accuracy	±0.2°C
Humidity	Measuring Range	0~100%
	Resolution	0.1%
	Accuracy	±0.2%F·S
Pre-Heating Time	30min	
Power Supply	Standard: AC220V±10%, 50/60Hz Optional: AC110V±10%, 50/60Hz	
Respiratory Chamber	Φ120*180mm, Φ60*89mm, Φ40*80mm Standard one, choose one of three types.	
External Size	260*260*130mm	
Package Size	550*400*250mm	
Net/Gross Weight	3.25kg/8kg	

Digital Fruit Sclerometer



Features:

- * Can store 896 peaks of data. The LED shows the peaks of data, and get rid of the data.
- * Can output data; analyze the data by connected with computer.
- * With digital peak value holding function, hold the peak value for 2 seconds and the peak value will be automatically cancelled.
- * Green environmental - protective: If you do not operate the machine after 10 seconds, the machine will be shut down automatically.

Technical Parameters:

Model	BK-DFS4	
Range	0.2 - 15 Kg/cm ² ($\times 10^5$ Pa)	0.4 - 30 Kg/cm ² ($\times 10^5$ Pa)
Division Value	0.01 Kg/cm ²	0.01 Kg/cm ²
Pressure Head Diameter	1# $\phi 11.1$ mm	2# $\phi 7.9$ mm
Precision	$\pm 1\%$	
Display Mode	Digital	
Net Weight	About 0.6KG	
Insertion Depth of Pressure Head	10mm	
Power Supply	220V 50Hz, 110V 60Hz	
Packing Size	290*190*120mm	
Gross Weight	1.6kg	

Multi-rice Wheat Thresher



Features:

- * Easy to thresh and with small loss.
- * Portable moving and easy cleaning.
- * Surface of the machine is treated by spraying plastic.
- * With strong corrosion resistance.

Technical Parameters:

Model	BK-MWT150
Roller Diameter	175 mm
Roller Rotation Speed	900 rpm
Overall Size	450*350*800mm
Weight	25kg
Power Supply	Standard: 220V 50Hz, optional: 110V 60Hz
Packing Size	540*420*910mm
Gross Weight	40kg

Vacuum Seed Counting & Placing Instrument



Features:

- * Used for seed counting, suction and placing in the course of seed germination.
- * Made up of main machine, suction tube and suction head.
- * With control button to control the suction power according to seed size.
- * With 5 different seed suction heads, its size and specification match with Petri dish, meet needs of different seed germination.

Technical Parameters:

Model	BK-SCP2000
Temperature	≤ 40 °C
Power	1200W at 220V 50Hz
Power Supply	Standard: 220V 50Hz, optional: 110V 60Hz
Suction Plate	5pcs
Suction Size	12*8.8 (25 holes, for corn, 1pc); 16.7*12 (1pc); 10.3*10.3 (25 holes, 2pcs), Φ8 (25 holes/pc)
Packing Size	540*390*490mm
Gross Weight	14kg

Sort	Sucked Seed	Sucked amount	Figure	Incubation utensil
A	Corn/Bean/Cotton Seed/Big Granule Vegetable Seed	25	Rectangle	PL18 PH18
B	Rice/Wheat/Barley/Kaoliang	100	Rectangle	PL18 PH18
C	Rice/Wheat/Barley/Kaoliang	100	Square	PL12 PH12
D	Rape seed and middle or small granule vegetable seed	100	Square	PL12 PH12
E	Small granule vegetable seed	100	Roundness	φ9mm glass utensil

Automatic Seed Counter



Application:

Automatic seed Counter can automatic count many kinds of grains by setting number. In agriculture it is mainly used in grain count, exp. Rice, wheat, sorghum, corn, vegetables seed and so on.

Features:

- * Two modes: Free count and bulk count.
- * The counting speed is adjustable.
- * High accuracy: Sensitivity levels for different size of particles.
- * Automatic deceleration: when counting number is close to the setting number, the counting speed slow down automatically.
- * Automatic motor Protection: the motor will stop work once it detects there is no particles on the plate for 60seconds.
- * User-friendly interface: LCD screen, mode selection, counting time, level and number of particles display clearly.
- * Widely application: suitable for particles includes but is not limited to: crops seeds, vegetable seeds, feed, diamond, tablet.

Technical Parameters:

Model	ASC-C plus
Count Range	1~12mm
Count Accuracy	±2‰
Count Speed	≥1000 /3min (Sesame)
Counting Range	1~99999
Noise	<70db
Power Supply	AC220/110V, 50/60Hz
Operation Environment	-10°C ~ 50°C, <85% RH
External Size(W*D*H)	285*210*176mm
Packing Size(W*D*H)	430*280*230mm
Gross Weight	9.5kg

Titrator

Potential Titrator

Features for Ti-40:

- * Large LCD screen
- * Integrated design of valve and burette
- * Built-in stirrer
- * Titration transmission device adopts linear motor design
- * With anti leakage device

Features for Ti-20:

- * Preset potential to control titration endpoint
- * Pre-control potential is adjustable
- * Solenoid valve for controlling dropping liquid
- * Equipped with delay circuit of titration endpoint
- * Equipped with stirrer



Technical Parameters:

Model	Ti-40	Ti-20
Measuring Range	pH: 0.00~14.00pH mV: -1800.0~1800.0mV Temp.: -5.0~105.0°C	pH: 0.00~14.00 Ph mV: ±1400mV
Measuring Resolution	pH: 0.01pH mV: 0.1mV Temp.: 0.1°C	pH: 0.01pH mV: 1mV
Measuring Accuracy	pH: ±0.01pH±1bit mV: ±0.03% (full scale) Temp.: ±0.3°C	pH: ±0.03pH±1 bit mV: ±5mV
Burette Volume Accuracy	10ml burette: ±0.025ml 20ml burette: ±0.035ml	/
Burette Supplementary Speed	55±10s (when burette is full scale)	/
Repeatability Titration Analysis	0.2%	/
Repeatability Accuracy	≤0.2mV	/
Stability	±0.3 mV±1bit/3h	±0.01pH/3h
Sensitive of Control Titration	±2mV	±5mV
Power Supply	AC110V/ 220V, 60Hz	
External Size(W*D*H)	340*400*400mm	300*235*100mm
Package Size(W*D*H)	540*490*480mm	490*410*300mm
Gross Weight	10kg	5kg

Karl Fischer Titrator



Coulometric electrolytic cup
Suitable for micro moisture samples



Sample titrate unit
Suitable for constant moisture samples

Features:

- * LCD display screen.
- * Titration methods, curves and results are displayed in detail.
- * Volumetric KF Titration and Coulometric KF Titration are supported.
- * Data analysis feature helps user review and compare results.
- * Data can be easily transferred to printer via RS-232 communication interface.
- * Reset feature automatically resumes all settings back to factory default options.

Volumetric Karl Fischer Titration:

- * Support KF Titration Mode and Titer Detection Mode.
- * Features of auto-filling, auto-purging and auto-mixing of the reagents ensure safe handling of Karl Fischer chemicals.
- * Automatic/manual background drift correction ensures accurate results.
- * Selectable units including mg, mg/L, %, ppm, etc.
- * Settable parameters, including measurement unit, polarization current, stirring rate, titration rate, stop volume, endpoint potential, stop criterion and etc.
- * Store up to 200 titration data sets (GLP-compliant).

Coulometric Karl Fischer Titration:

- * Generator cell with diaphragm.
- * Automatic/manual background drift correction ensures accurate results.
- * Selectable units including ug, mg, %, ppm, mg/L, ug/mL, etc
- * Settable parameters, including measurement unit, polarization current, stirring rate, generator current, endpoint potential, stop criterion and etc.
- * Store up to 200 titration data sets (GLP-compliant).

Technical Parameters:

Model	KFT-40VC	
Volumetric Titration	Range	0.1~250mg
	Polarization Current Accuracy	1µA±0.2µA; 50µA±10µA
	Repeatability	≤0.5%
Coulometric Titration	Range	10µg~20mg
	Polarization Current Accuracy	±0.2µA
	Working Current	1, 1.86, 5, 10ug(H ₂ O)/s for 10.72mA, 20 mA, 53.61mA, 107.2 mA
	Working Current Accuracy	0.5%
	Accuracy	±(5%+3)µg
General	Repeatability	≤3%
	Power Supply	AC110~240V, 50Hz
	External Size	340*400*400mm
	Net Weight	10kg
	Package Size	540*490*480mm
Gross Weight	13kg	

Karl Fischer Titrator

Features:

- * LCD display screen.
- * Support KF Titration Mode and Titer Detection Mode.
- * Features of auto-filling, auto-purging and auto-mixing of the reagents ensure safe handling of Karl Fischer chemicals.
- * Selectable units including mg, mg/L, %, ppm, etc.
- * Settable parameters, including measurement unit, polarization current, stirring rate, titration rate stop volume, endpoint potential, stop criterion and etc.
- * Store up to 200 titration data sets (GLP-compliant).
- * Data can be easily transferred to printer via RS-232 communication interface.
- * Reset feature automatically resumes all settings back to factory default options.



Technical Parameters:

Model	KFT-40C	
Volumetric Titration	Range	0.1mg~250mg
	Resolution	0.1mg
	Polarization Current Accuracy	1 μ A \pm 0.2 μ A; 50 μ A \pm 10 μ A
	Repeatability	\pm 0.5%
General Parameters	Power Supply	110~220V, 50/60Hz
	External Size(mm)	340*400*400
	Packing Size (mm)	540*490*480
	Net/Gross Weight (kg)	10/12

Electronic Titrator

Features:

- * High quality motor with excellent precision and accuracy
- * Electronic control provides a fatigue-free operation
- * Remote control panel prevents manual disturbance during operation
- * Built-in magnetic stirrer for a complete and easy operation



Technical Parameters:

Model	dTrite
Cat No.	7017100001
Volume Range	0.01mL-99.99mL, Max piston lift is 10mL, resolution is 10 μ L
Volume Accuracy	R=0.2% CV=0.07%
Velocity	16 stages
Operating Temperature Range	10-30°C
Quality Control	DIN EN ISO 8655
Control Type	External control, including the stirrer and the burette program
Power Supply	100~240VAC, 50/60 Hz
Package Size(W*D*H)	300*240*220mm
Gross Weight	1.62kg

Water Activity Meter

Application:

Water activity meter, indicates the free water content when food is stable, measures the possibility of microbial proliferation. Food formulators use water activity to predict how much moisture migration will affect their product, so that to choose suitable package and storage method to reduce the usage of antiseptics.



Features:

- * The measured object is unlimited, liquid solids and powder etc
- * Printer output as standard accessory
- * Chemical resistant. (only for BWA-6)

Technical Parameters:

Model	BWA-3A	BWA-6
Working Temp.	0~50°C	-10°C~50°C
Working Humidity	0~95%RH	
Display	LCD display	
Measuring	Temperature	0~50°C
Range	Water Activity	0~0.980
Measurement	Temperature	-10°C~50°C
Accuracy	Water Activity	0~1.000
	Temperature	\pm 0.5°C
	Water Activity	\pm 0.015 (@25°C)
		\pm 0.012 (@23°C \pm 5°C)
Measurement Time	5~40min	
Measurement Points	1	1~4
Temperature Coefficient	\leq 0.0005/°C	
Activity Repeatability	\leq 0.015	\leq 0.008
Print Function	a. Print at the end of the measurement b. Real-time print	
Correction Mode	Single-point calibration	Multi-point joint calibration, single-point calibration
Interface	\	RS232, USB
Standard Accessories	Micro printer, one sensor	Data cable, micro printer, one sensor
Consumption	15W	10W
Power Supply	AC110/220V \pm 10%, 50/60Hz	
Package Size(W*D*H)mm	550*430*240	740*430*240
Gross Weight(kg)	11.5	15.5

Cooking Oil Tester

Features:

- * Waterproof design, class IP65.
- * Using AA battery, 500 times measurement.
- * Adopting food-grade materials, safety and eco-friendly for probes.
- * 1Easy operation, field testing, suitable for a variety of testing conditions.
- * Special design for probe in order to reduce residual oil and easy for clean.
- * Fast measurement, getting result within 15 seconds with sound-light alarm.
- * Adopting streamlined design, according to Ergonomics, easy handing and preventing it to fall apart.



Technical Parameters:

Model	COT-28A		
Tempe. Measure Range	0~200.0°C	Storage Temperature	-40~+70 °C
Temp. Resolution	± 0.1°C	Display	LED display
Temperature Accuracy	± 1.0°C	Frame Material	ABS
TPM Measure Range	0~50%	Probe Material	Food-grade stainless steel
TPM Accuracy	± 1.5% (40.0~190.0 °C)	Protection Grade	IP 65
TPM Resolution	± 0.1%	TPM Sensor	Capacitive sensor
Temperature Sensor	PTC Sensor	Weight (with the probe cases)	About 218g
TPM Response Time	<15S	Bluetooth	Yes
LED Status Alert	Green, Orange, Red	WiFi	Yes
Operating Temperature	0~+50 °C	Auto-Calibrate	Yes
Battery Life Below 20°C	About 25 hours of continuous use time (the corresponding measuring 500 times)		
Packing Size(L*D*H)	420*160*85mm		
Gross Weight	1.1kg		

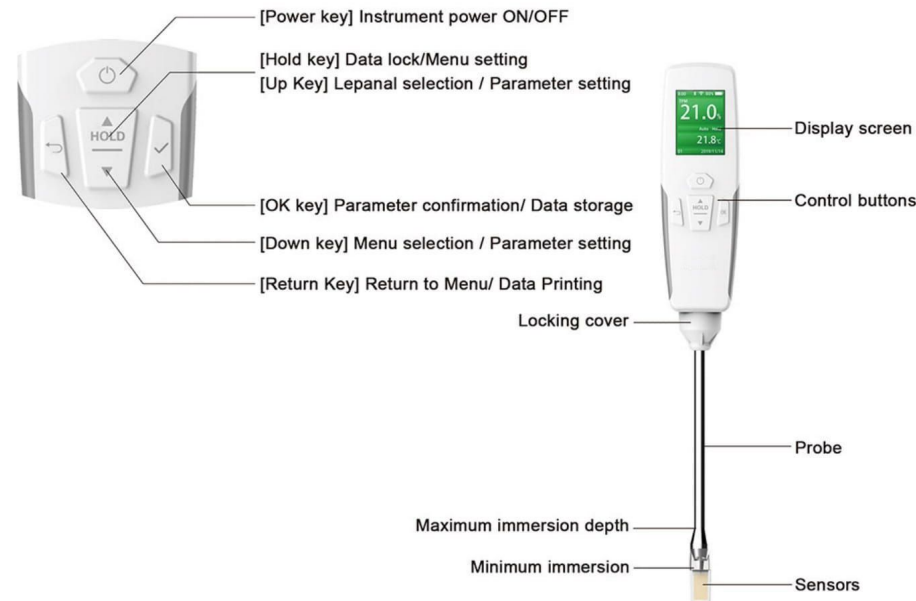

Introduction:

The Cooking Oil Tester is a fast, safe and efficient instrument for testing the quality of edible oil, with short testing time and fast response time. No chemical reagents are used in the measurement process to ensure maximum food and environmental safety. This product detects the total polar material (TPM) in cooking oil to reflect the degree of aging of cooking oil. This product can be directly measured in high temperature oil (not more than 200C), suitable for all kinds of frying grease quality rapid inspection.

Technical Parameters:

Model	COT-280		
Temperature Range	0~+200°C	Response time	about 15s (50°C)
Temperature Accurance	±1°C	Data printing	Bluetooth printer (optional)
Temperature Resolution	0.1°C	Display type	TFT High Definition LCD
TPM Range	0~50% TPM	Display specifications	2.0 inch, 240*320 resolution, 5 levels of brightness adjustable
TPM Accuracy	±2% TPM (40°C -190°C)	Battery type	approximately 500 times of measurements (factory default configuration)
TPM Resolution	0.1% TPM	Class of Protection	IP65
Temperature Sensor	PTC sensor	Dimension (LxWxH)	347mm×50.5mm×37.5mm
TPM Sensor	Capacitive sensor	Net weight	218g (without battery, with case)
Communication	WIFI, Bluetooth	Shell material	food-grade ABS/PET
Packing Size	400*160*80mm		
Gross Weight	1.5kg		

Grain Moisture Meter

Application:

It is used for fast and accurate measurement of moisture in the process of allotment, acquisition, storage, machining of packed grains.



Technical Parameters:

Model	TK100G/100GF	TK25G	TK100S	MS-G
Measuring Range	6~30%(professional)	6~30%(professional)	0~35%(general)	5~40%(professional)
Temp. Range of Measured Grain	-10~60°C			
Humidity Range	5~90%			
Resolution	0.1			
Accuracy	±0.5%			
Grains	6 types(For type TK100G)	25 types	4 types	25 types
Grain Flour	11 groups (For type 100GF)	/	Flour and starch only	11 groups(standard)
Power Supply	4*Common AAA battery			
Package Size(W*D*H)	504*110*54mm			266*206*76mm
Gross Weight	0.7kg	0.7kg	0.7kg	0.8kg

Model	Grain & Powder List
TK100G	Wheat, Corn, soybean, rice paddy, rice, barley
TK100GF	Wheat flour, rice powder, corn flour, semolina, soybean meal, barley powder, coffee powder, sorghum flour, flaxseed meal, pea meal, soft wheat flour
TK25G	Wheat, corn, soybean, rice paddy, rice, barley, sorghum, buckwheat, peas, rapeseed, mustard seed, sunflower seed, beet seeds, coffee, coffee(green), cocoa beans, flaxseed, lentils, fruit with hard shell, rye grass seed, duck feather grass seed, clover(white seed), clover(black seed), canola, bean,
TK100S	Wheat, rice, corn, soybeans, wheat flour
MS-G	Wheat, corn, soybean, rice paddy, rice, barley, sorghum, buckwheat, peas, rapeseed, mustard seed, sunflower seed, beet seeds, coffee, coffee(green), cocoa beans, flaxseed, lentils, fruit with hard shell, rye grass seed, duck feather grass seed, clover(white seed), clover(black seed), canola, bean, wheat flour, rice powder, corn flour, semolina, soybean meal, barley powder, coffee powder, sorghum flour, flaxseed meal, pea meal, soft wheat flour

Viscometer

Digital Viscometer BDV-S and BDV-N Series



BDV-1S



BDV-9S



BDV-5S/8S



BDV-N Series

Features:

BDV-S series digital viscometer:

- * Central control circuit: 16 bit MCU.
- * Gearless driving, LCD display.
- * Optional accessories: Printer(BDV-5S and BDV-8S) and RTD temperature probe(not including BDV-1S).

BDV-N series digital viscometer:

- * Measurement is more larger than BDV-S series.
- * Rotating speed is improved to non-polar shift.
- * RTD temperature probe can timely monitor the temperature of the sample.
- * Optional software: Data Collecting, Analysis and Plot Software.

Technical Parameters:

Model	BDV-1S	BDV-9S	BDV-5S	BDV-8S	BDV-1N	BDV-2N	BDV-3N	BDV-4N	
Measured Range (mPa·s)	1~100,000	1~6,000,000	20~100,000	20~2,000,000	20~600,000	12~6,000,000	160~80,000,000	50~10,000,000	
Rotation Speed(rpm)	6, 12, 30, 60	0.1, 0.3, 0.6, 1.5, 3, 6, 12, 30, 60	6, 12, 30, 60	0.3, 0.6, 1.5, 3, 6, 12, 30, 60	1~60	0.1~99.9	0.1~99.9	0.1~200	
Number of Spindle	4 types(L1~L4)				4 types(L1~L4)			4 types (21.27.28.29)	
Measurement Accuracy	±5%(FS) (Newtonian Fluid)	±3%(FS) (Newtonian Fluid)	±1%(FS)(Newtonian Fluid)						
Repeatability	±0.5% (FS)(Newtonian Fluid)								
Power Supply	AC 100~240V, 50/60Hz								
Standard accessory	/	/	RS232 standard output interface		RTD temperature probe, RS232 standard output interface				
Optional accessory	/	RTD temperature probe	RTD temperature probe, Specially used printer		Specially used printer				
L0 Spindle is for Option Measured Range(mPa.s)	1~10	1~10	1~100	1~2000	1~600	0.6~6000	6~6000	3~6000	
Package Size (W*D*H)	460*390*230mm		400*350*360mm					400*350*550mm	
Gross Weight	7.5kg		9kg			10.5kg			

Digital Viscometer BDV Series

Features:

- * Central control circuit: 16 bit MCU.
- * RTD temperature probe can timely monitor the temperature of the sample.
- * LCD can display all information.
- * Optional software: DV Program Control Download Software & Data Collecting, Analysis and Plot Software.



Technical Parameters:

Series	BDV-1			BDV-2		
Model	BDV-1A	BDV-1B	BDV-1C	BDV-2A	BDV-2B	BDV-2C
Measured Range (mPa·s)	12~6M	80~40M	640~320M	6~6M	40~40M	320~320M
Rotation Speed(rpm)	0.1~99.9 non-polar shift			0.1~200 non-polar shift		
Number of Spindle	4 (L1~L4)	6 (R2~R7)	6 (R2~R7)	4 (L1~L4)	6 (R2~R7)	6 (R2~R7)
Measurement Accuracy	±1%(FS) (Newtonian Fluid)					
Repeatability	±0.5%(FS) (Newtonian Fluid)					
Power Supply	AC 100~240V, 50/60Hz					
Standard accessory	RS232 standard output interface, RTD temperature probe					
Optional accessory	Specially used printer					
L0 Spindle is for Option						
Measured Range (mPa·s)	0.6~6000	6~60000	50~500000	0.3~6000	3~60000	25~500000
R1 Spindle is for Option						
Measured Range (mPa·s)	/	20~100000	160~800000	/	10~100000	80~800000
Package Size(mm)	400*350*360	400*350*550	400*350*550	400*350*360	400*350*550	400*350*550
Gross Weight(kg)	9	10.5	10.5	9	10.5	10.5

Digital Viscometer BKU-1



Features:

- * LCD display
- * BKU-1 viscometer is specially applied to sample like paint, coating, etc.
- * Central control circuit: 16 bit MCU.
- * It can recyclingly show the units of KU, gm, and cP.

Technical Parameters:

Model	BKU-1
Measure Range	40~141KU 32~1099gm 27~5274cP
Measurement Accuracy	±1% (FS)(Newtonian Fluid)
Repeatability	±0.5%(FS)(Newtonian Fluid)
Rotation Speed	200rpm
Power Supply	AC 100~240V, 50/60Hz
Package Size(mm)	400*350*360
Gross Weight(kg)	10

Note: cP is for reference, not for calibration.

Water Softener



Full-Automatic Softening Valve



Imported Polishing Resin

Introduction:

Water softener mainly uses ion exchange resin to remove calcium and magnesium ions in water, reducing water hardness.

Features:

- * Conventional well flushing, back flushing, salt absorption, automatic water replenishing operation, no personnel guard;
- * Counter current regeneration technology, prolonging the service life of resin;
- * Ion exchange technology can effectively remove scale;
- * Regular conventional well flushing and back flushing, labor-saving;
- * Imported resin to ensure softening effect;
- * Perfect after-sales service, free 1 year warranty (except consumables).



Pretreatment of Pure Water Machine



Boiler Softening Water



Household Soft Water

Technical Parameters:

Model	BKRSY-500	BKRSY-1000	BKRSY-2000
Source of Intake Water	Water pressure is 0.2-0.5Mpa, hardness <4mmol/L		
Ambient Temp.	2 ~ 45°C		
Working Pressure	0.2-0.5Mpa		
Water Consumption	≤ 2% of water yield		
Salt Consumption	100~250g/mol		
Power Consumption	10~40W		
Residual Hardness of Effluent	≤ 0.03mmol/L		
Total Pressure Loss	0.03MPA		
Water Production	500L(Customized)	1000L(Customized)	2000L(Customized)
Power Supply	AC110~220V,50~60Hz		
Net Weight	26kg	40kg	44kg
Gross Weight	28kg	42kg	46kg
Product Size	455*245*610mm	470*330*730mm	490*330*1270mm
Package Size	475*275*500mm	510*360*960mm	530*360*1160mm

Note:Valves are shipped in separate packaging

Water Purifier Laboratory Water Purifier



Features:

- * Nano RO membrane filters tiny substances more efficiently.
- * Fully automatic control, one-key boot, simple operation.
- * With high pressure and low pressure protection, safer operation.
- * With consumable replacement alarm.
- * Compliance with national standard GB/T6682-2008 water requirements.
- * LCD display, display water quality information.

Technical Parameters:

Model	SCSJ-II-20L	SCSJ-II-30L	SCSJ-II-40L
Water Output Type	RO water outlet*1 and DI water outlet*1		
Water Output Speed	20 L/H	30 L/H	40 L/H
Purifying Procedure	PF+AC+RO+DI		
Water Supply Requirement	When working, the inlet water pressure is 0.1-0.3Mpa, and the water quality meets the requirements of GB5749, 15 ~ 35°C		
Environmental Requirements	Temperature 15 ~ 35°C Relative Humidity ≤80%		
Purification System	10"PP filter*1, 10"active carbon filter*1 300GPD RO membrane*1 Deionization purification column*1		
DI Water Quality	Resistivity	10-18.25MΩ.cm	
	Conductivity	0.055-0.1μs/cm	
	Heavy metal	<0.1ppb	
	Particle	<1/ml	
RO Water Quality	Bacteria	<0.1cfu/ml	
	Ion rejection rate	96%-99%	
	Organic rejection rate	>99%	
	Particles and bacteria rejection rate	>99%	
Flow Rate	1750ml/min		
Consumption	113W		
Power Supply	AC220V±10%, 50Hz±5% (Standard); AC110V, 60Hz (Optional)		
Standard Configuration	Main body , 25Lwater tank, accessory pack		
Instrument Size(W*D*H)	403*325*650mm		
Package Size(W*D*H)	Instrument	460*420*1200mm	
	Accessory Box	670*400*260mm	
Gross Weight	40kg		

Laboratory Water Purifier



Features:

- * Nano RO membrane filters tiny substances more efficiently.
- * Fully automatic control, one-key boot, simple operation.
- * With high pressure and low pressure protection, safer operation.
- * With consumable replacement alarm.
- * Compliance with national standard GB/T6682-2008 water requirements.
- * LCD display, display water quality information.

Technical Parameters:

Model	SCSJ-II-60L	SCSJ-II-60LZ	SCSJ-II-80L	SCSJ-II-100L
Water Output Type	RO water outlet*1 and DI water outlet*1		RO water outlet*1 and DI water outlet*2	
Water Output Speed	60 L/H		80 L/H	100 L/H
Purifying Procedure	PF+AC+RO+DI			
Water Supply Requirement	When working, the inlet water pressure is 0.1-0.3Mpa, and the water quality meets the requirements of GB5749, 5 ~ 45°C			
Environmental Requirements	Temperature 15 ~ 35°C Relative Humidity ≤80%			
Purification System	Precision filter*1; Deionization purification column*1 300GPD RO membrane*2 (SCSJ-II-60L,SCSJ-II-60LZ,SCSJ-II-80L) 400GPD RO membrane*2 (SCSJ-II-100L)			
DI Water Quality	Resistivity	10-18.25MΩ.cm@25°C		
	Conductivity	0.055-0.1μs/cm		
	Heavy metal	<0.1ppb		
	Particle	<1/ml		
RO Water Quality	Bacteria	<0.1cfu/ml		
	Ion rejection rate	96%~99%		
	Organic rejection rate	>99%		
	Particles and bacteria rejection rate	>99%		
Flow Rate	1000ml/min	2500ml/min		
Consumption	60W	84W	144W	
Power Supply	AC220V±10%, 50Hz±5% (Standard); AC110V, 60Hz (Optional)			
Standard Configuration	Main body , 50Lwater tank, accessory pack			Main body ,80L water tank(0.5 gallon pressure tank), accessory pack
Instrument Size(W*D*H)	400*393*1002mm			
Package Size(W*D*H)	Instrument	490*480*1095mm	490*480*1100mm	
	Tank	415*415*700mm	415*415*700mm	
	Accessory Box	680*400*230mm	675*395*230mm	
Gross Weight	45kg			70kg

Features:

- * Nano RO membrane filters tiny substances more efficiently.
- * Fully automatic control, one-key boot, simple operation.
- * With high pressure and low pressure protection, safer operation.
- * With consumable replacement alarm.
- * Compliance with national standard GB/T6682-2008 water requirements.
- * LCD display, display water quality information.

Technical Parameters:

Model	SCSJ-II-120L	SCSJ-II-150L	SCSJ-II-200L
Water Output Type	RO water outlet*2 and DI water outlet*2		
Water Output Speed	120 L/H	150 L/H	200 L/H
Purifying Procedure	PF+AC+RO+DI		
Water Supply Requirement	When working, the inlet water pressure is 0.1-0.3Mpa, and the water quality meets the requirements of GB5749, 15 ~ 35°C		
Environmental Requirements	Temperature 15 ~ 35°C Relative Humidity ≤80%		
Purification System	20"PP filter*1, 20" granular active carbon filter*1 , 20" compressed activated carbon filter*1, 400GPD RO membrane *2, Deionization purification column*2		
DI Water Quality	Resistivity	10-18.25MΩ.cm	
	Conductivity	0.055-0.1μs/cm	
	Heavy metal	<0.1ppb	
	Particle	<1/ml	
RO Water Quality	Bacteria	<0.1cfu/ml	
	Ion rejection rate	96%~99%	
	Organic rejection rate	>99%	
	Particles and bacteria rejection rate	>99%	
Pressure Bucket	Built-in	External	External
Consumption	230W		
Power Supply	AC220V±10%, 50Hz±5%(Standard); AC110V, 60Hz(Optional)		
Standard Configuration	Main body , pressure bucket, accessory pack		
Instrument Size(W*D*H)	750*600*1200mm		
Package Size(W*D*H)	Instrument	770*620*1350mm	
	Pressure tank	/	390*390*775mm
	Accessory	555*315*170mm	
Gross Weight	110kg	123kg	



Laboratory Water Purifier

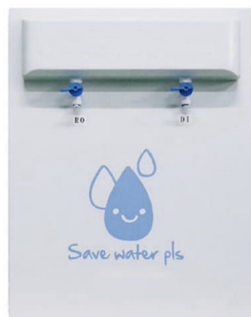

Features:

- * Nano RO membrane filters tiny substances more efficiently.
- * Fully automatic control, one-key boot, simple operation.
- * With high pressure and low pressure protection, safer operation.
- * With consumable replacement alarm.
- * Compliance with national standard GB/T6682-2008 water requirements.

Technical Parameters:

Model	SCSJ-I-10L	SCSJ-I-15L
Water Output Type	RO water outlet*1 and DI water outlet*1	
Water Output Speed	10 L/H	15 L/H
Purifying Procedure	PF+AC+RO+DI	
Water Supply Requirement	When working, the inlet water pressure is 0.1-0.3Mpa, and the water quality meets the requirements of GB5749, 15 ~ 35°C	
Environmental Requirements	Temperature 15 ~ 35°C Relative Humidity ≤80%	
Purification System	10"PP filter*1, 10"active carbon filter*2 50GPD RO membrane *1 Deionization purification column*2	
DI water Quality	Resistivity	10-18.25MΩ.cm
	Conductivity	0.055-0.1μs/cm
	Heavy metal	<0.1ppb
	Particle	<1/ml
	Bacteria	<0.1cfu/ml
RO water Quality	Ion rejection rate	96%~99%
	Organic rejection rate	>99%
	Particles and bacteria rejection rate	>99%
Flow Rate	167ml/min	250ml/min
Consumption	46W	
Power Supply	AC220V±10%, 50Hz±5%(Standard); AC110V, 60Hz(Optional)	
Standard Configuration	Main body	
Instrument Size(W*D*H)	390*400*503mm	
Package Size(W*D*H)	500*520*650mm	
Gross Weight	27kg	

Water Purifier (Automatic RO/DI Water)



Technical Parameters:

Model	SCSJ-III 15	SCSJ-III 30
Display	LCD	
Water Output Type	RO and DI water	
Water Output Speed	15L/H	30L/H
Purifying Procedure	PF+AC+RO+DI	
Water Supply Requirement	Tap water: TDS<200ppm, 5~45°C, 1.0~4.0Kg/cm² (If inlet TDS>200ppm, extra pretreatment filter is recommended)	
Purification System	Pretreatment unit	PP filter *1, Special active carbon filter *2
	RO unit	100GPD RO membrane*1
	Subsequent unit	Deionization purification column (imported resin) *2
Pure Water Quality	Ion rejection rate	97%~99% (New RO membrane)
	Organic rejection rate	>99%, when MW>200 Dalton
	Particles and bacteria rejection rate	>99%
	Resistivity	15~18.2MΩ.cm
	Conductivity	0.055~0.067μs/cm
Control System	Automatic electronic pressure sensor controlling, RO membrane auto flushing, Automatic stop when water supply shortage, Automatic stop when water tank full, Automatic cutting off water when pump stop, 24 hours non-stop work	
Flow Rate	2.0 L/min (when there is water in the water tank)	
Water Quality Monitor	TDS/conductivity test pen	
Consumption	72W	
Power Supply	AC220V±10%, 50Hz±5%(Standard); AC110V, 60Hz(Optional)	
Standard Configuration	Main body(include 1 set of purification column),15L water tank, TDS/conductivity test pen,accessory pack	
External Size(W*D*H)	410*220*420mm	
Package Size(W*D*H)	600*490*580mm	
Gross Weight	35kg	

Water Purifier Medium Type (Automatic RO/DI Water)



Features:

- * Large LCD display, animation mode, show all the running state and parameters.
- * Automatic microcomputer control system, multi-menu operating,
- * Alarm function: Water quality, no water, full water, consumables life ending. Automatic diagnosis.
- * 3-way on-line sensor, detect the quality of feed water, RO water and DI water's quality timely.

Technical Parameters:

Model	SCSJ-V 45	SCSJ-V 63	SCSJ-V 94	SCSJ-V 125	
Water Output Type	RO and DI water				
Water Output Speed	45L/H	63L/H	94L/H	125L/H	
Purifying Procedure	PF+AC+RO+AC+DI+TF				
Water Supply Requirement	Tap water: TDS<200ppm, 5~45°C, 1.0~4.0Kgf/cm ² (if TDS>200ppm, extra pretreatment filter is recommended)				
Purification System	Pretreatment unit	20"PP filter*1, 20" granular active carbon filter*1, 20" active carbon block filter*1			
	RO unit	300 GPD RO membrane*1	400 GPD RO membrane*1	600 GPD RO membrane*1	400 GPD RO membrane*2
Subsequent unit	Organic matter purification column*1; 12L ultra-purified column (imported resin)*1; 0.2µm imported PES terminal filter*1				
DI Water Quality	Resistivity	10-18.2MΩ.cm			
	Conductivity	0.1-0.055µs/cm			
	Heavy metal	<0.1ppb			
	Bacteria	<0.01cfu/ml			
Particle(>0.2µm)	<1/ml				
Flow Rate	3.0 L/min (when there is water in the water tank)				
RO Water Quality	TDS(Total dissolved solid) of RO water(ppm)<TDS of inlet water*5%				
Consumption	120W		240W		
Power Supply	AC220V±10%, 50Hz±5%(Standard); AC110V, 60Hz(Optional)				
Standard Configuration	Main body(include 1 set of purification column), 2 built-in 15 liters tank, accessory pack				
External Size(W*D*H)	640*540*1110mm				
Package Size(W*D*H)	650*750*1280mm				
Gross Weight	90kg				

Water Purifier Medium Type (Automatic RO Water)



Features:

- * Large LED display, show all the running state and parameters.
- * RO membrane clean automatically. High/Low pressure protection.
- * Alarm function: Water quality, no water, full water, consumables life ending. Automatic diagnosis.

Technical Parameters:

Model	SCSJ-IV 45	SCSJ-IV 63	SCSJ-IV 94	SCSJ-IV 125	
Water Output Type	RO water				
Water Output Speed	45L/H	63L/H	94L/H	125L/H	
Purifying Procedure	PF+AC+AC+RO				
Water Supply Requirement	Tap water: TDS<200 ppm, 5~45°C, 1.0~4.0Kgf/cm ² (if TDS>200ppm, extra pretreatment filter is recommended)				
Purification System	Pretreatment unit	20" PP filter*1, 20" granular active carbon filter*1, 20" active carbon block filter*1			
	RO unit	300 GPD RO membrane*1	400 GPD RO membrane*1	600 GPD RO membrane*1	400 GPD RO membrane*2
Pure Water Quality	Ion rejection rate	97%~99% (New RO membrane)			
	Organic rejection rate	>99%, when MW>200 Dalton			
	Particles and bacteria	>99%			
	Rejection rate	<0.01cfu/ml (with optional 0.2µm PES terminal filter)			
	Bacteria	<1/ml (with optional 0.2µm PES terminal filter)			
Particles(>0.2µm)	TDS meter, Online resistivity monitor(optional)				
Water Quality Monitor	120W		240W		
Consumption	AC220V±10%, 50Hz±5%(Standard); AC110V, 60Hz(Optional)				
Power Supply	Main body (Including 1 set of purification column), 2 built-in 15L water tank,				
Standard Configuration	TDS/conductivity test pen, accessory pack				
External Size(W*D*H)	640*540*1110mm				
Package Size(W*D*H)	650*750*1280mm				
Gross Weight	90kg				

Water Purifier (Automatic RO Water)

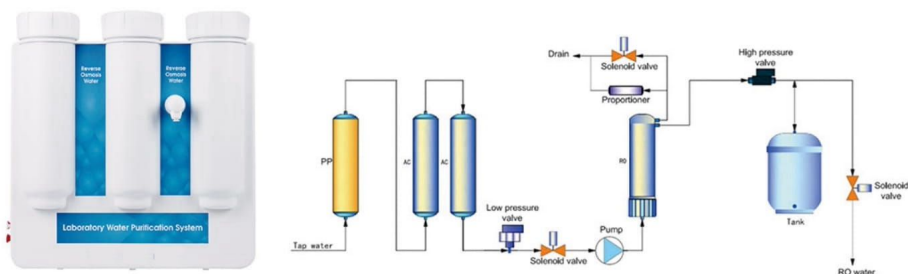

Technical Parameters:

Model		SCSJ-II 15	SCSJ-II 30
Water Output Type		RO water	
Water Output Speed		15L/H	30L/H
Purifying Procedure		PF+AC+RO+AC	
Water Supply Requirement		Tap water: TDS<200 ppm, 5~45°C, 1.0~4.0Kg/cm ² (if inlet TDS>200ppm, extra pretreatment filter is recommended)	
Purification System	Pretreatment unit	PP filter *1(SCSJ-II 15), PP cotton filter *1(SCSJ-II 30), Special active carbon filter *2	
	RO unit	100GPD RO membrane *1	200GPD RO membrane *1
Pure Water Quality	Ion rejection rate	97%~99% (New RO membrane)	
	Organic rejection rate	>99%, when MW>200 Dalton	
	Particles and bacteria rejection rate	>99%	
	Bacteria	<0.1cfu/ml (with optional 0.45+0.1µm PES terminal filter)	
	Particles(>0.2µm)	<1/ml (with optional 0.45+0.1µm PES terminal filter)	
Flow Rate		2.0L/min (with pressure tank)	
Water Quality Monitor		TDS/conductivity test pen	
Consumption		72W	
Power Supply		AC220V±10%, 50Hz±5%(Standard); AC110V, 60Hz(Optional)	
Standard Configuration		Main body (Include 1 set of purification column), 15 liters tank, TDS/conductivity test pen, accessory pack	
External Size(W*D*H)		410*220*420mm	
Package Size(W*D*H)		600*490*580mm	
Gross Weight		35kg	

Water Purifier Medium Type (Automatic Ultra-pure Water)



Features:

- * UV type with UV lamp, Double wavelength(185&254nm), sterilizer and reduce TOC, expand the usage range.
- * UF type with UF filter, Eliminate the endotoxin efficiently.
- * Other features same as Automatic RO/DI water purifier.

Technical Parameters:

Model	SCSJ-VI	SCSJ-VII	SCSJ-VIII	SCSJ-IX
	Basic	Eliminating endotoxin UF	Low TOC UV	Synthesizing UVF
Water Output Type		RO and ultra-pure water		
Water Output Speed		45/63/94/125 L/H		
Purifying Procedure		PF+AC+RO+AC+DI	PF+AC+RO+AC+DI+UF	PF+AC+RO+AC+UV+DI
Water Supply Requirement		Tap water: TDS<200 ppm, 5~45°C, 1.0~4.0Kg/cm ² (if TDS>200ppm, extra pretreatment filter is recommended)		
Purification System	Pretreatment Unit	20" PP filter*1, 20" granular active carbon filter*1, 20" active carbon block filter*1		
	RO unit	300 GPD RO membrane*1 (for 45L) 400 GPD RO membrane*1 (for 63L) 600 GPD RO membrane*1 (for 94L) 400 GPD RO membrane*2 (for 125L)		
Subsequent unit		Organic matter purification column*1 12L ultra-purified column (imported resin)*1 0.2µm imported PES terminal filter*1 Ultra Purification Column*2 MWCO5000D UF ultrafiltration module (SCSJ-VII and SCSJ-IX) Dual wavelength (185nm&254nm) UV lamp (SCSJ-VIII,SCSJ-IX)		
		Resistivity(25°C) 18.2MΩ.cm		
Ultrapure Water Quality	Heavy Metal Ion	<0.01ppb		
	TOC	<10ppb		
	Bacteria	<0.01cfu/ml		
	Endotoxin	N/A	<0.001Eu/ml	N/A
	Particle(>0.2µm)	<1/ml		
	RNases	N/A	<1pg/ml	N/A
	DNases	N/A	<5pg/µl	N/A
ROWater Quality	Ion Rejection Rate	97%~99% (New RO membrane)		
	Organic Rejection Rate	>99%, when MW>200 Dalton		
	Pa rticles And Bacteria Rejection Rate	>99%		
Flow Rate		3.0 L/min (when there is water in the water tank)		
Power Supply		AC220V±10%, 50Hz±5%(Standard); AC110V, 60Hz(Optional)		
Consumption		(45/63L/H):120W ; (94/125L/H):240W		
Standard Configuration		Main body (Include 1 set of purification column), 2 built-in15L tank, accessory pack		
External Size(W*D*H)		640*540*1110mm		
Package Size(W*D*H)		650*750*1280mm		
Gross Weight		90kg		

Ultrapure Water Purifier

Features:

- * Water supply, RO water, UP water three water quality detection, all levels of consumables life alarm.
- * 5 inch LCD screen, real-time display of running status.
- * It has the function of taking water at regular time.
- * High and low pressure protection function.
- * Automatically shut down when water is cut off, automatically shut off water when shut down.
- * Automatic washing after starting, effectively extend the life of filter element.
- * Pressure water, to meet different customer requirements.



Technical Parameters:

Model	BK-UP-20L	BK-UP-30L
Water Output Type	UP water outlet*1, RO water outlet*1, DI water outlet*1	
Water Output Speed(25°C)	20 L/H	30 L/H
Purifying Procedure	PF+AC+RO+AC+UV+UP+TF	
Water Supply Requirement	When working, the inlet water pressure is 0.1-0.3Mpa, and the water quality meets the requirements of GB57492, 5 ~ 40°C	
Purification System	PP filter *1 Granular activated carbon filter*1 High quality coconut shell activated carbon filter *1 Large T33 filter RO membrane *2 UV lamp *1 ultra-purification column *4 Capsule filter *1	
UP Water Quality	Resistivity	18.2MΩ.cm
	Conductivity	0.055μs/cm
	Heavy Metal	<0.1ppb
	Particle	<1/ml
	Bacteria	<0.01cfu/ml
	TOC	<50ppb
DI Water Quality	Resistivity	10-18.2MΩ.cm
	Conductivity	0.055-0.1μs/cm
	Heavy Metal	<0.1ppb
	Particle	<1/ml
	Bacteria	<0.1cfu/ml
RO Water Quality	Ion Rejection Rate	96%~99%
	Organic Rejection Rate	>99%
	Particles And Bacteria Rejection Rate	>99%
Consumption	74W	
Power Supply	100~240V 50/60Hz	
Instrument Size(L*W*H)	386*481*461mm	
Package Size(L*W*H)	Main body: 540*455*540mm, 21.5kg Accessory kit: 425*295*475mm, 5kg	
Gross Weight	26.5kg	

Features:

- * Water supply, RO water, UP water three water quality detection, all levels of consumables life alarm.
- * 5 inch LCD screen, real-time display of running status.
- * It has the function of taking water at regular time.
- * High and low pressure protection function.
- * Automatically shut down when water is cut off, automatically shut off water when shut down.
- * Automatic washing after starting, effectively extend the life of filter element.
- * Pressure water, to meet different customer requirements.



Technical Parameters:

Model	BK-UP-40L	BK-UP-60L
Water Output Type	UP water outlet*1, RO water outlet*1, DI water outlet*1	
Water Output Speed(25°C)	40 L/H	60 L/H
Purifying Procedure	PF+AC+RO+AC+UV+UP+TF	
Water Supply Requirement	When working, the inlet water pressure is 0.1-0.3Mpa, and the water quality meets the requirements of CJ/T206	
Purification System	PP filter *1	
	Granular activated carbon filter *1 (postposition)	
	400GPD RO membrane *1	
	75GPD RO membrane *1	
	Large T33 filter *1	
	UV lamp *1	
	Ultra-purification column *4	
	Capsule filter *1	
UP Water Quality	Resistivity	18.1MΩ.cm@25°C
	PH	4.4-7.6
	Sodium Ion	<0.1μg/l
	Chloride Ion	<0.1μg/l
	Heavy Metal Ion	<0.1μg/l
	Si	<2μg/l
	Nitrate	≤0.06μg/ml
	Nitrite	≤0.02μg/ml
	Ammonia	≤0.3μg/ml
	Heavy Metal	<0.1μg/ml
DI Water Quality	Bacteria	<1cfu/100ml
	TOC	20μg/l
	Resistivity	10-18.1MΩ.cm@25°C
	Absorbance	≤0.001
	Soluble silicon (SiO2)	≤0.01
RO Water Quality	Ion Rejection Rate	96%~99%
	Organic Rejection Rate	>99%
	Particles And Bacteria Rejection Rate	>99%
Consumption	100W	
Power Supply	100~220V 50/60Hz	
Instrument Size(L*W*H)	386*481*461mm	
Package Size(L*W*H)	Main body: 540*455*540mm, 21.5kg Accessory kit: 425*295*475mm, 5kg	
Gross Weight	26.5kg	

Water Purifier Consumables

Model Type	PP filter	5µm PP deep filter	20" PP filter	PP carbon filter	Active carbon filter	Granular active carbon filter	Active carbon block filter	12L Deionization purification column (imported resin)	Deionization purification column (imported resin)	12L ultra-purified column (imported resin)	Ultra-purified column (imported resin)	100/200 /300/400 /600 GPD RO membrane	Organic matter purification column	0.2µm precision terminal filter	MWCO 5000D UF ultrafiltration module	Deal length (185nm & 25nm) UV lamp
Replacement term/(months)	2-6	5-6	2-3	5-6	4-6	2-6	2-6	about 1000L pure water/set	about 1000L pure water/set	about 20000L pure water/set	about 1000L pure water/set	12-24	about 8000L pure water/set	/	/	about 9000 hours
SCSJ-I (15UH)	/	/	/	/	2	/	/	/	/	/	/	100*1	/	/	/	/
SCSJ-II (30UH)	/	/	/	/	2	/	/	/	/	/	/	200*1	/	/	/	/
SCSJ-III (15UH)	/	/	/	/	2	/	/	2	/	/	/	100*1	/	/	/	/
SCSJ-III (30UH)	/	1	/	/	2	/	/	3	/	/	/	200*1	/	/	/	/
SCSJ-IV (45UH)	/	/	1	/	/	1	/	/	/	/	/	300*1	/	/	/	/
SCSJ-V (63UH)	/	/	/	/	/	1	/	/	/	/	/	400*1	/	/	/	/
SCSJ-VI (94UH)	/	/	1	/	/	1	/	/	/	/	/	600*1	/	/	/	/
SCSJ-VII (125UH)	/	/	1	/	/	1	/	/	/	/	2	400*2	/	/	/	/
SCSJ-VIII (45UH)	/	/	1	/	/	1	/	/	/	1	2	300*1	/	/	/	/
SCSJ-IX (63UH)	/	/	1	/	/	1	/	/	/	1	2	400*2	/	/	/	/
SCSJ-X (94UH)	/	/	1	/	/	1	/	/	/	1	2	600*1	/	/	/	/
SCSJ-XI (125UH)	/	/	1	/	/	1	/	/	/	1	2	400*2	/	/	/	/
SCSJ-XII (45UH)	/	/	1	/	/	1	/	/	/	1	2	300*1	/	/	/	/
SCSJ-XIII (63UH)	/	/	1	/	/	1	/	/	/	1	2	400*1	/	/	/	/
SCSJ-XIV (94UH)	/	/	1	/	/	1	/	/	/	1	2	600*1	/	/	/	/
SCSJ-XV (125UH)	/	/	1	/	/	1	/	/	/	1	2	400*2	/	/	/	/
SCSJ-XVI (45UH)	/	/	1	/	/	1	/	/	/	1	2	300*1	/	/	/	/
SCSJ-XVII (63UH)	/	/	1	/	/	1	/	/	/	1	2	400*1	/	/	/	/
SCSJ-XVIII (94UH)	/	/	1	/	/	1	/	/	/	1	2	600*1	/	/	/	/
SCSJ-XIX (125UH)	/	/	1	/	/	1	/	/	/	1	2	400*2	/	/	/	/
SCSJ-XX (45UH)	/	/	1	/	/	1	/	/	/	1	2	300*1	/	/	/	/
SCSJ-XXI (63UH)	/	/	1	/	/	1	/	/	/	1	2	400*1	/	/	/	/
SCSJ-XXII (94UH)	/	/	1	/	/	1	/	/	/	1	2	600*1	/	/	/	/
SCSJ-XXIII (125UH)	/	/	1	/	/	1	/	/	/	1	2	400*2	/	/	/	/

Model Type	PP filter	T33 filter element	Active carbon filter	Granular active carbon filter	Precision filter	20" compressed activated carbon filter	Capsule filter	Deionization purification column	50/300 /400/4021 GPD RO membrane
Replacement term/(months)	4-6	4-6	4-6	4-6	4-6	4-6	4-6	/	12
SCSJ-I-10L	10**1	/	2	/	/	/	/	3000L*2	50*1
SCSJ-I-15L	10**1	/	2	/	/	/	/	3000L*2	50*1
SCSJ-II-20L	10**1	/	1	/	/	/	/	5000L*1	300*1
SCSJ-II-30L	10**1	/	1	/	/	/	/	5000L*1	300*1
SCSJ-II-40L	10**1	/	1	/	/	/	/	5000L*1	300*1
SCSJ-II-60L	/	/	/	/	1	/	/	8000L*1	300*2
SCSJ-II-80L	/	/	/	/	1	/	/	8000L*1	300*2
SCSJ-II-100L	/	/	/	/	1	/	/	8000L*1	400*2
SCSJ-II-120L	20**1	/	/	/	1	/	/	20000L*2	400*2
SCSJ-II-150L	20**1	/	/	/	1	/	/	20000L*2	400*2
SCSJ-II-200L	20**1	/	/	/	1	/	/	20000L*2	400*2
SCSJ-V-45L	20**1	1	/	1	/	1	1	20000L*1	300*1

Water Distiller

Electric-heating Water Distiller



Features:

- * Stainless steel material, adopt stamping and welding technology.
- * Corrosion and ageing resistance, easy to operate, safe and durable.

Technical Parameters:

Model	WD-5	WD-10	WD-20
Water Output	≥5L/H	≥10L/H	≥20L/H
Consumption	5KW	7.5KW	15KW
Power Supply	AC110/220V, 50/60Hz	380V, 50Hz	380V, 50Hz
External Size(Φ*H)	310*700mm	355*820mm	405*677mm
Package Size(W*D*H)	360*360*820mm	360*350*900mm	540*390*740mm
Gross Weight	7.5kg	8.5kg	11.5kg

Auto-control Electric-heating Water Distiller



Features:

- * Stainless steel material, adopt stamping and welding technology.
- * Water shortage and power-off alarm.
- * Power, heating indicator and show water shortage.

Technical Parameters:

Model	WD-A5	WD-A10	WD-A20
Water Output	≥5L/H	≥10L/H	≥20L/H
Consumption	5KW	7.5KW	15KW
Power Supply	AC110/220V, 50/60Hz	380V, 50Hz	380V, 50Hz
External Size(Φ*H)	310*740mm	235*855mm	415*720mm
Package Size(W*D*H)	360*360*830mm	360*360*920mm	535*380*770mm
Gross Weight	8kg	9.5kg	13kg

Laboratory Wastewater Treatment System



BK-SFS200

BK-SFS500

Application:

Medical center, Physical and chemical inspection, PCR laboratory, Operating room, Beauty center



Features:

- * Perfect processing technology
Various kinds of pollutants in sewage are treated by chemical reaction, aeration oxidation, ozone disinfection, multi-medium filtration, ultraviolet lamp disinfection and other technologies.
- * Intelligent monitoring
The intelligent man-machine control system is adopted to monitor and control the change of sewage quality and the treatment process in real time, so as to realize all-weather automatic operation without special person on duty.
- * High-efficient sterilization
Compared with the traditional equipment, this system has the advantages of simple and convenient operation and strong sterilization ability.
- * Accurate dosing
Imported metering pump is used to accurately control the dosage, and equipped with liquid level control, drug shortage alarm and other devices.
- * Easy operating
Easy to operate, stable operation, long service life, low cost of operation and maintenance.

Technical Parameters:

Model	BK-SFS200	BK-SFS500
Treated Water Volume	200L/Day (8 hours)	500L/Day (8 hours)
PH Measurement Range	0-14	
PH Adjustment Value	6-9	
Resolution	0.01pH	
Accuracy	±0.02pH	
Processing System	Neutralization precipitation + compound disinfection (ozone oxidation, Oxidizing agent oxidation) + UV sterilization+ multi-stage filtration	Neutralization precipitation + compound disinfection (ozone oxidation, Oxidizing agent oxidation) + UV sterilization+ multi-stage filtration+ aeration + photocatalysis(optional)+ microelectrolysis
Flush Mode	With positive and negative flushing methods	
Water Input Way	Imbibition inlet	Imbibition inlet and artesian inlet
Antifreeze Device	With antifreeze heating function, the antifreeze function starts automatically when the degree is lower than 5°C.	
Lack of Fluid Alarm	Multi-channel liquid level detection, with drug liquid shortage alarm function, automatic waste water treatment.	
Power Supply	Standard: 220V 50/60Hz, optional: 110V 50/60Hz	
Packing Size(W*D*H)	Machine:1055*559*948mm	Machine:1500*710*1415mm
	Accessories: 315*555*165mm	Accessories: 515*515*1315mm
Gross Weight	102.5kg	220kg

Medical Wastewater Treatment System



Application Field:



Medical center



Physical and chemical inspection



PCR laboratory



Operating room



Beauty center

Features:

- * Safety and sanitation
No need to add chemical agents, more safe and hygienic operation
- * Intelligent monitoring
The intelligent man-machine control system is adopted to monitor and control the change of sewage quality and the treatment process in real time, so as to realize all-weather automatic operation without special person on duty.
- * High-efficient sterilization
Compared with the traditional equipment, this system has the advantages of simple and convenient operation and strong sterilization ability.
- * Easy operating
Easy to operate, stable operation, long service life, low cost of operation and maintenance.

Technical Parameters:

Model	BK-SFS30H
Treated water volume	30L/H
Maximum Lift	25m
Maximum Suction	8m
Max Flow	1.8m ³ /h
Control Method	Manual/Auto
Processing system	Primary treatment, ozone oxidation, UV sterilization(optional), sediment
Water Input Way	Imbibition inlet
Sterilization Principle	Ozone sterilization, ozone capacity 500mg/h
Control Method	Three control modes, cycle, single level, double level mode (optional)
Power Supply	Standard: 220V 50/60Hz, optional: 110V 50/60Hz
Packing size(W*D*H)	595*555*715mm
Gross weight	33kg





Herais
Lab Solutions

HERAIS INTERNATIONAL

100 Bessemer Rd. London ON N6E 1R2 Canada

www.herais.ca

Tel: +1 519 800 1353

Email: higtc@windowlive.com

www.heraisprojects.com